

# **PARTS CATALOGUE**

**ECO 150 (Dec, 2019)**

## E-1 CYLINDER HEAD COVER

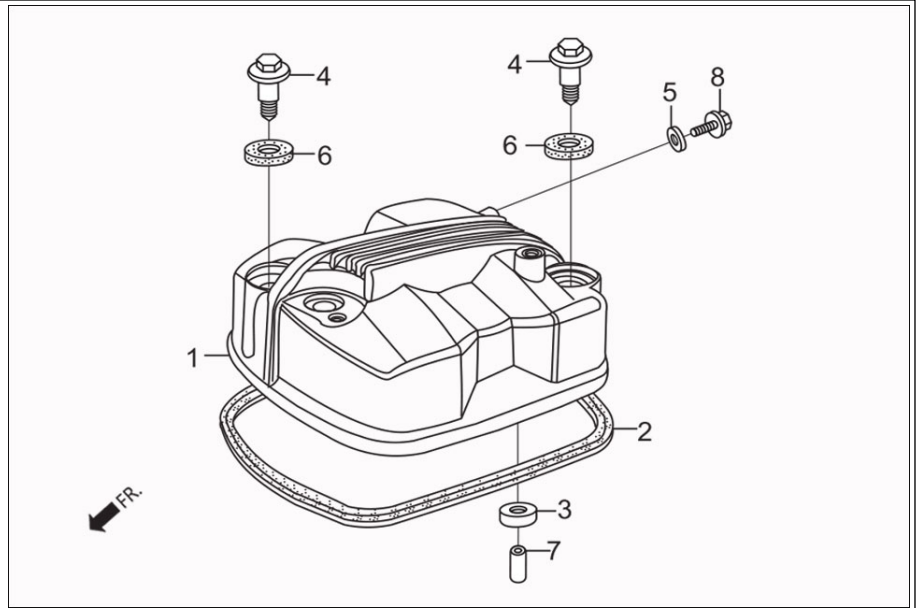

Service Item	F.R.T.
* COVER COMP., CYLINDER HEAD	0.3
* GASKET, HEAD COVER	--

**Group Number:** E-1 Model :: ECO 150 (Dec, 2019)

Ref No.	Part Number	Description	Req.
1	12311-AAM-300	COVER, CYLINDER HEAD	1
2	12391-KRM-840	GASKET, HEAD COVER	1
3	12396-KRM-840	GASKET,B, HEAD COVER	1
4	90003-KFG-000	BOLT, L COVER	2
5	90463-KRM-840	WASHET SEALING 6.2 MM	1
6	90543-MV9-670	RUBBER, MOUNT	2
7	94301-08140	DOWEL PIN, 8X14	1
8	96001-06012-00	BOLT,FLANGE,SH,,6 X 12	1

# E-1A CYLINDER HEAD

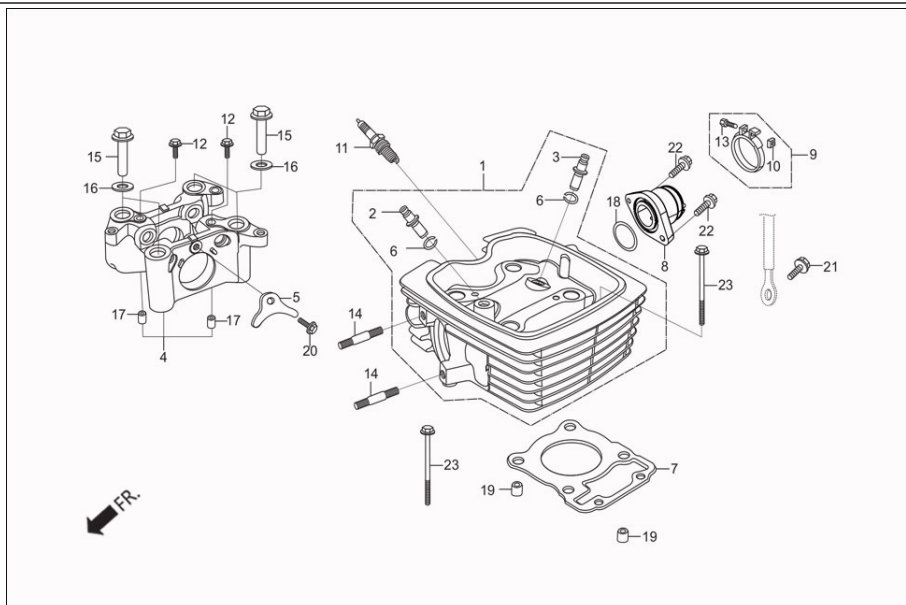

<b>Service Item</b>	<b>F.R.T.</b>	<b>Group Number: E-1A Model :: ECO 150 (Dec, 2019)</b>			
* PLUG, SPARK	0.1	<b>Ref No.</b>	<b>Part Number</b>	<b>Description</b>	<b>Req.</b>
* BOLT, STUD, 8 X 22	0.3	1	12200-AAM-300	CYLINDER HEAD	1
( ADD 0.1 FOR EACH)	--	2	12204-KRM-305	GUIDE VALVE, (O. S.)	1
* INSULATOR COMP., CARBURETOR	0.4	3	12205-KSP-305	GUIDE, INLET, VALVE (O.S.)	1
* HOLDER COMP., CAMSHAFT	0.9	4	12210-KSP-910	HOLDER COMP., CAM SHAFT	1
* GASKET, CYLINDER HEAD	1.4	5	12212-KRM-840	PLATE, STOPPER	1
* GUIDE IN VALVE	2.0	6	12213-KSP-910	CLIP VALVE GUIDE	2
(INC. REAMING)	--	7	12251-KSP-910	GASKET, CYLINDER HEAD	1
(ADD 0.3 FOR EACH)	--	8	16210-AAM-100	INSULATOR COMP CARB	1
(EXC. VALVE REFACING)	--	9	16217-KSP-910	BAND INSULATOR	1
(ADD MORE 0.2 IF PERFORMED)	--	10	16222-KSP-910	NUT, SQUARE, 5 MM	1
* HEAD COMP., CYLINDER	2.2	11	31916-KRM-84099	SPARK PLUG	1
		12	90002-KRM-840	BOLT, FLANGE 5X14	2
		13	90006-MEE-000	BOLT RECESSED 5 X 30	1
		14	90040-KSP-910	BOLT STUD 8 X 22	2
		15	90306-KRM-840	NUT CYLINDER HEAD	4
		16	90404-KPT-A00	WASHER PLAIN 12MM	4
		17	90704-KRM-840	DOWEL PIN 6 X10	2
		18	91304-KRM-840	O-RING 33.5 X 3.0	1
		19	94301-10120	DOWEL PIN, 10X12	2
		20	95701-06014-00	BOLT, FLANGE, 6 X 14	1
		21	95701-06016-00	BOLT, FLANGE, 6X16	1
		22	95701-06022-00	BOLT, FLANGE, SH. 6 X 22	2
		23	95801-06105-00	BOLT FLANGE 6 X 105	2

**E-2**  
CAM SHAFT / VALVE

FR. ←

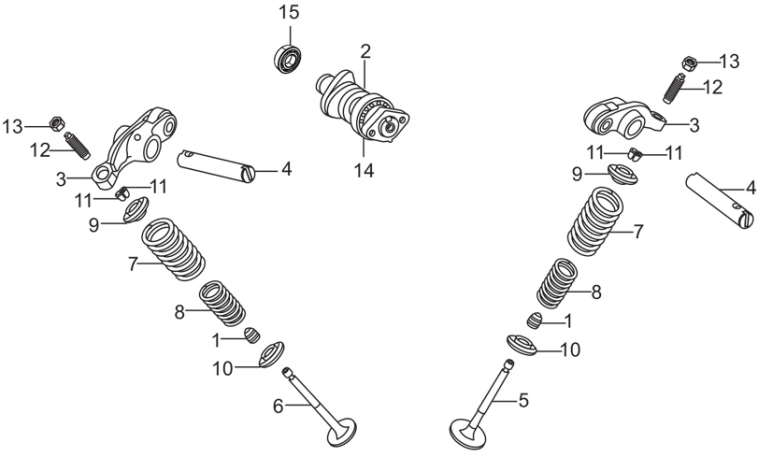

Service Item	F.R.T.	Group Number: E-2 Model :: ECO 150 (Dec, 2019)			
		Ref No.	Part Number	Description	Req.
		1	12209-AAN-410	SEAL VALVE STEM	2
		2	14100-KTN-900	SHAFT COMP., CAM	1
		3	14430-KSP-910	ARM COMP., VALVE ROCKER	2
		4	14451-KRM-840	SHAFT, ROCKER ARM	2
		5	14711-KSP-910	VALVE, INLET	1
		6	14721-KSP-910	VALVE, EXH.	1
		7	14751-KTN-900	SPG, VALVE, OUTER	2
		8	14761-KTN-900	SPG, VALVE, INNER	2
		9	14771-KSP-910	RETAINER, VALVE SPRING	2
		10	14777-KSP-910	SEAT, VALVE SPRING	2
		11	14781-MA6-000	COTTER, VALVE	4
		12	90012-KK3-830	SCREW, TAPPET ADJUSTING	2
		13	90206-250-000	NUT, TAPPET ADJUSTING	2
		14	91007-KTN-900	BRG. BALL RADIAL, 17 X 35 X 10	1
		15	91008-KTN-900	BRG. BALL RADIAL, 12 X 28 X 8	1

**E-3**  
CYLINDER

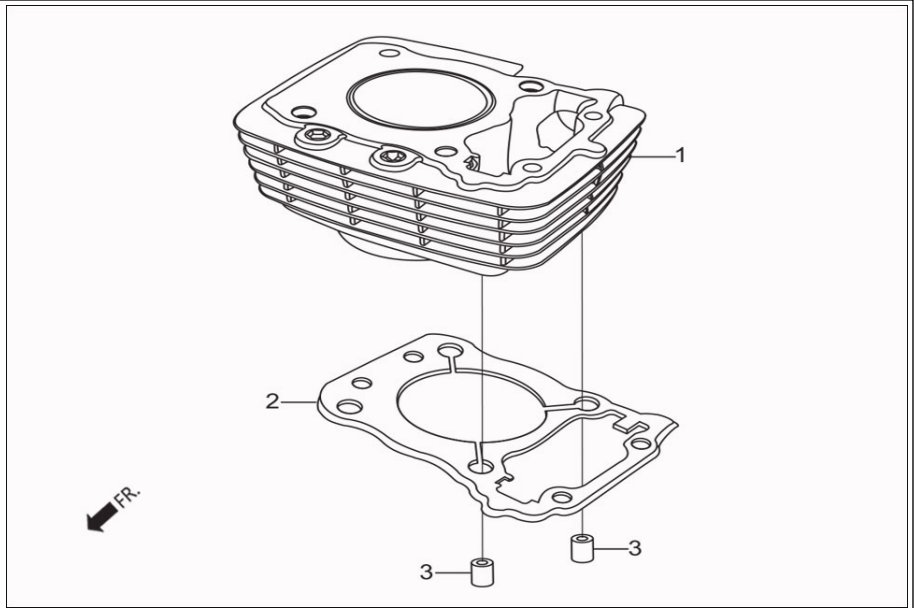

Service Item	F.R.T.
* GASKET, CYLINDER	1.6
* CYLINDER COMP.,	1.7

Group Number: E-3 Model :: ECO 150 (Dec, 2019)

Ref No.	Part Number	Description	Req.
1	12100-AAM-300	CYLINDER	1
2	12191-KWK-900	GASKET, CYLINDER	1
3	94301-10120	DOWEL PIN, 10X12	2

**E-4**  
CAM CHAIN TENSIONER

← FR.

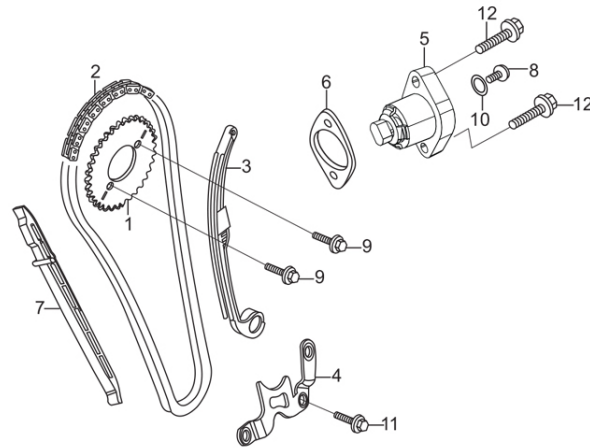



Service Item	F.R.T.	Group Number: E-4 Model :: ECO 150 (Dec, 2019)			
		Ref No.	Part Number	Description	Req.
		1	14321-KRM-840	SPROCKET, CAM, (34T)	1
		2	14401-KCW-851	CHAIN, CAM	1
		3	14510-KVE-900	TENSIONER ASSY.,CAM CHAIN	1
		4	14515-KRM-840	PLATE, TENSIONER SET	1
		5	14520-AAB-A0099	LIFTER ASSY TENSIONER	1
		6	14560-KSP-910	GASKET, TENSIONER LIFTER	1
		7	14610-KSP-910	GUIDE CAM CHAIN	1
		8	90005-KY7-000	SCREW, PAN, 6X6	1
		9	90083-KRM-840	BOLT, KNOCK, 5 MM	2
		10	91306-MG3-000	O- RING, 1.5X9.5	1
		11	95701-06016-00	BOLT, FLANGE, 6X16	1
		12	96001-06022-00	BOLT, FLANGE, SH. 6 X 22	2

**E-5**  
RIGHT CRANK CASE COVER

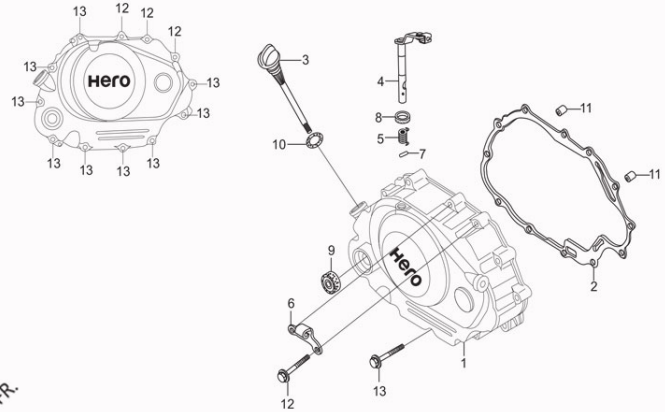

<b>Service Item</b>	<b>F.R.T.</b>	<b>Group Number: E-5 Model :: ECO 150 (Dec, 2019)</b>			
* GASKET, R CRANKCASE COVER	0.6	<b>Ref No.</b>	<b>Part Number</b>	<b>Description</b>	<b>Req.</b>
* OIL SEAL ,16 X28 X 27	--	1	11330-AAM-300	COVER COMP R CRANK CASE	1
* COVER COMP., R CRANKCASE	0.7	2	11393-KWK-900	GASKET, RIGHT COVER	1
* LEVER COMP., CLUTCH	--	3	15651-KTN-900	GAUGE, OIL LEVEL	1
(INC. RELATIVE PART)	--	4	22810-KVE-900	LEVER COMP., CLUTCH	1
		5	22815-428-000	SPRING, CLUTCH LEVER	1
		6	22821-KRM-840	RECEIVER, CLUTCH CABLE	1
		7	90701-KFN-850	PIN, SPRING, 3 X 10	1
		8	91202-KSP-911	OIL SEAL, 12 X 18 X 4	1
		9	91204-MC7-003	OIL SEAL, 16 X 28 X 7	1
		10	91307-KRM-840	O-RING, 18 X 3	1
		11	94301-08140	DOWEL PIN, 8X14	2
		12	96001-06030-00	BOLT, FLANGE, SH., 6 X 30	3
		13	96001-06040-00	BOLT, FLANGE, SH. 6 X 40	9

**E-6**  
CLUTCH

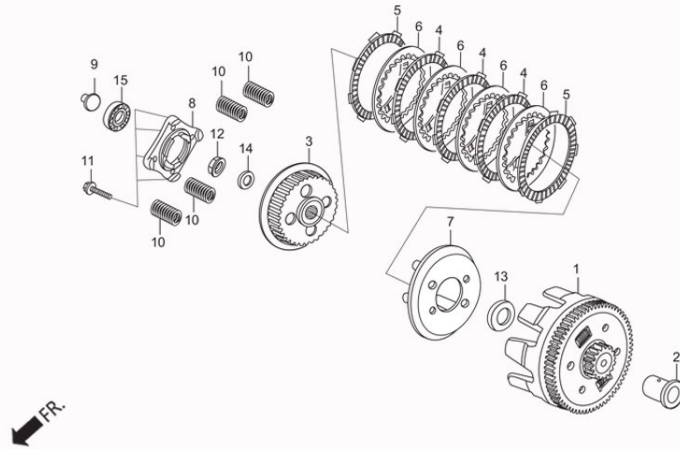

<b>Service Item</b>	<b>F.R.T.</b>	<b>Group Number: E-6 Model :: ECO 150 (Dec, 2019)</b>			
* ROD, CLUTCH LIFTER	0.6	<b>Ref No.</b>	<b>Part Number</b>	<b>Description</b>	<b>Req.</b>
* SPRING, CLUTCH (SAME TIME FOR TWO UNITS OR MORE)	0.7	1	22100-KTN-900	OUTER COMP., CLUTCH	1
* CENTER, CLUTCH	0.8	2	22115-KSP-910	GUIDE, CLUTCH OUTER	1
* DISC, CLUTCH FRICTION (INC. RELATIVE PART) (SAME TIME FOR TWO UNITS OR MORE)		3	22120-KRM-840	CENTRE CLUTCH	1
* OUTER COMP., CLUTCH		4	22201-KPM-850	DISK,CLUTCH FRICTION,4 X 8 X 45	3
		5	22201-MR8-000	DISC CLUTCH FRICTION	2
		6	22321-KPS-900	PLATE, CLUTCH	4
		7	22355-KRM-840	PLATE, CLUTCH PRESSURE	1
		8	22361-KPK-900	PLATE,CLUTCH LIFTER	1
		9	22366-KSP-910	ROD, CLUTCH LIFTER	1
		10	22401-KRM-840	SPRING CLUTCH	4
		11	90008-KRM-840	BOLT, FLANGE 6 X 25	4
		12	90202-KRM-840	NUT SPL FLANGE 14MM	1
		13	90401-KRM-840	WASHER PLAIN 17MM	1
		14	90501-KPT-A00	WASHER 14.1X29X2.8	1
		15	96100-60030-00	BEARING, RADIAL BALL, 6003	1

**E-7A**  
A. C. GEN. ASSY.

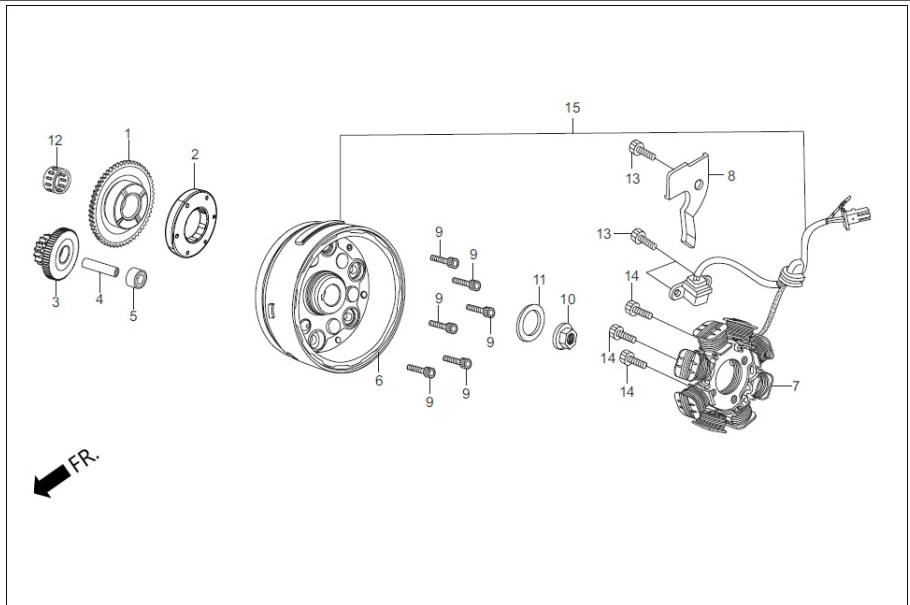

Service Item	F.R.T.	Group Number: E-7A Model :: ECO 150 (Dec, 2019)			
		Ref No.	Part Number	Description	Req.
		1	28110-KTN-900	GEAR COMP., STARTER DRIVEN	1
		2	28120-KTR-A00A	ASSY. ONEWAY CLUTCH	1
		3	28131-KTN-900	GEAR STARTER REDUCTION	1
		4	28132-KN6-930	SHAFT, REDUCTION GEAR	1
		5	28133-KRM-850	COLLAR, STARTER REDUCTION	1
		6	31110-KSP-902	FLY WHEEL COMP.	1
		7	31120-KSP-911	STATOR COMP.	1
		8	32111-KSP-910	CLAMPER, ACG CORD	1
		9	90085-KTC-920	BOLT, SOCKET, 6 X 14	6
		10	90201-KRM-840	NUT, FLANGE, 14 MM	1
		11	90501-KPT-A00	WASHER 14.1X29X2.8	1
		12	91022-KTN-900	BEARING NEEDLE, 22 X 29 X 16.8	1
		13	96600-06016-00	BOLT, SOCKET, 6 X 16	3
		14	96600-06025-00	BOLT, SOCKET, 6 X 25	3
		15	31100-KTN-901	AC GEN ASSY.	1

**E-7B**  
STARTER MOTOR

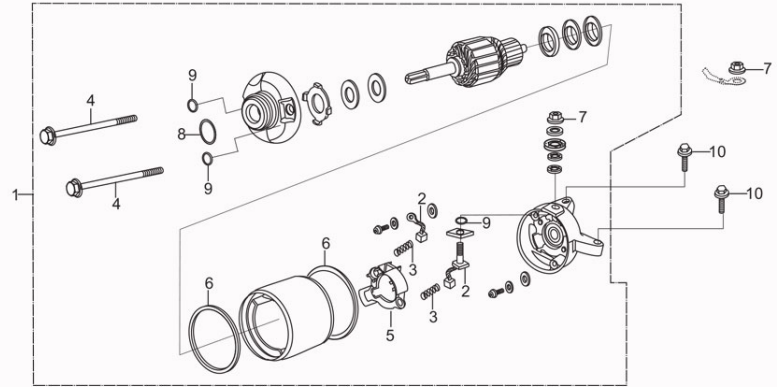

FR.



<b>Service Item</b>	<b>F.R.T.</b>	<b>Group Number: E-7B Model :: ECO 150 (Dec, 2019)</b>			
* MOTOR ASSY., STARTER	0.7	<b>Ref No.</b>	<b>Part Number</b>	<b>Description</b>	<b>Req.</b>
* BRUSH, TERMINAL SET	0.9	1	31200-KSP-901	MOTOR ASSY., STARTER	1
		2	31201-KPT-A01	BRUSH, TERMINAL SET	2
		3	31204-KG8-004	BRUSH, SPRING	2
		4	31205-KTC-921	BOLT, SET	2
		5	31206-KPH-881	BRUSH, HOLDER SET	1
		6	31207-MBE-008	RING	2
		7	90071-MB0-000	NUT, WASHER, 6 MM	2
		8	91309-425-003	O RING 24.4X3.1	1
		9	91320-MB0-000	O RING	3
		10	95701-06022-00	BOLT, FLANGE, SH. 6 X 22	2

**E-7C**  
LEFT CRANK CASE COVER

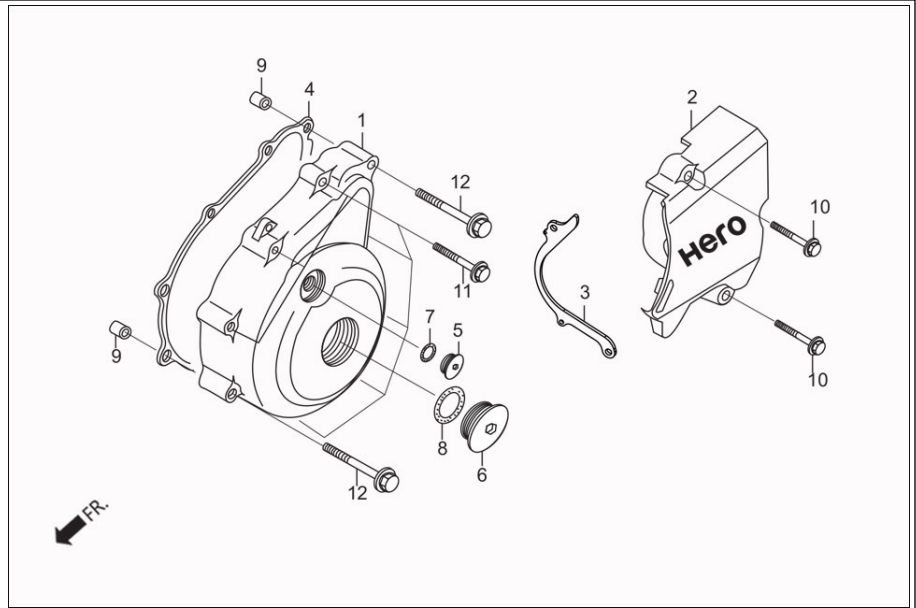

<b>Service Item</b>	<b>F.R.T.</b>	<b>Group Number: E-7C Model :: ECO 150 (Dec, 2019)</b>			
		<b>Ref No.</b>	<b>Part Number</b>	<b>Description</b>	<b>Req.</b>
* COVER COMP., L RR	0.1	1	11341-AAM-300	COVER, LEFT CRANK CASE	1
* GASKET, L COVER	0.2	2	11360-AAM-300	COVER COMP L REAR	1
* COVER, L CRANKCASE	0.3	3	11365-KSP-910	GUIDE DRIVE CHAIN	1
		4	11395-KWK-900	GASKET, L COVER	1
		5	90084-KWA-930	CAP 14 MM	1
		6	90087-AAM-300	CAP, 32 MM	1
		7	91303-KRM-840	O-RING 13.8 X 2.5	1
		8	91305-KRM-840	O-RING 31.7 X 2.4	1
		9	94301-08140	DOWEL PIN, 8X14	2
		10	96001-06030-00	BOLT, FLANGE, SH., 6 X 30	2
		11	96001-06035-00	BOLT, FLANGE, SH. 6 X 35	7
		12	96001-06045-00	BOLT, FLANGE, SH. 6 X 45	2

# E-8

## CRANK CASE

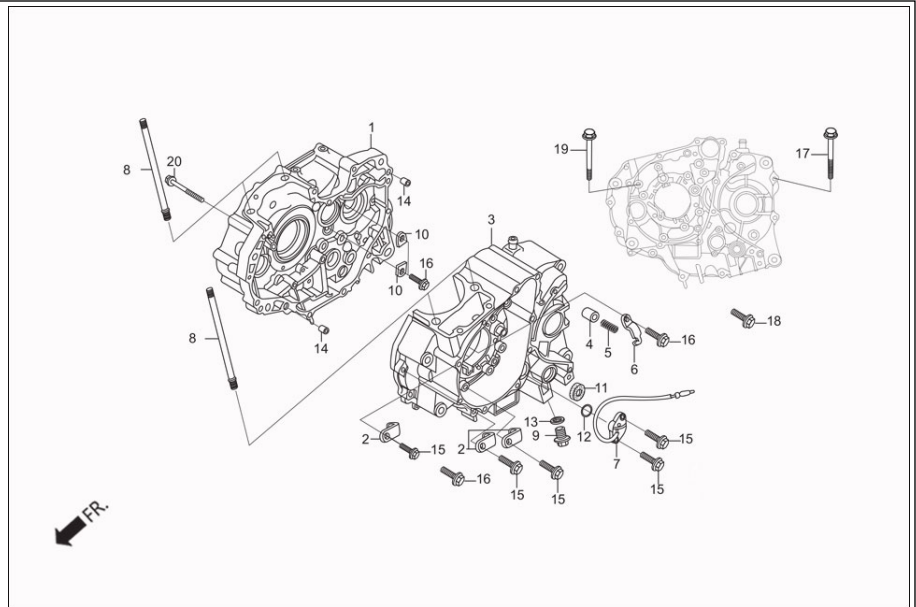

<b>Service Item</b>	<b>F.R.T.</b>
* CONTACT ASSY., NEUTRAL SW	0.3
* BOLT, STUD, CYLINDER, 8 X 140 (ADD 0.1 FOR EACH)	1.6 --
* CRANKCASE COMP., L	*4.2
* CRANKCASE COMP., R	*4.5

<b>Group Number: E-8 Model :: ECO 150 (Dec, 2019)</b>				
<b>Ref No.</b>	<b>Part Number</b>	<b>Description</b>	<b>Req.</b>	
1	11100-AAM-300	CRANK CASE COMP RIGHT	1	
2	11108-KTN-900	PLATE L BRG SET	3	
3	11200-AAM-300	CRANK CASE COMP LEFT	1	
4	11215-KSP-910	PLUG BRG PUSH	1	
5	11216-KRM-840	SPRING BRG PUSH	1	
6	11217-KRM-840	PLATE BRG PUSH	1	
7	35759-KTN-900	CONTACT ASSY, NEUTRAL SW	1	
8	90031-KSP-910	BOLT STUD CYLN 8 X 140	4	
9	90131-KRM-840	BOLT, PLUG, DRAIN, 12 MM	1	
10	90441-KRM-840	PLATE, BRG. HOLD	2	
11	91203-KSP-910	OIL SEAL, 14 X 22 X 5	1	
12	91305-KPH-900	O-RING,19.4 X 2.3	1	
13	94109-12000	WASHER, PLUG, DRAIN	1	
14	94301-08140	DOWEL PIN, 8X14	2	
15	95701-06016-00	BOLT, FLANGE, 6X16	5	
16	95701-06020-00	BOLT, FLANGE, 6X20	2	
17	95701-06040-00	BOLT FLANGE 6X40	7	
18	95701-06045-00	BOLT, FLANGE, SH. 6 X45	1	
19	95701-06070-00	BOLT, FLANGE, SH. 6 X70	7	
20	96001-06018-00	BOLT, FLANGE, 6 X 18	1	

# E-8A OIL PUMP

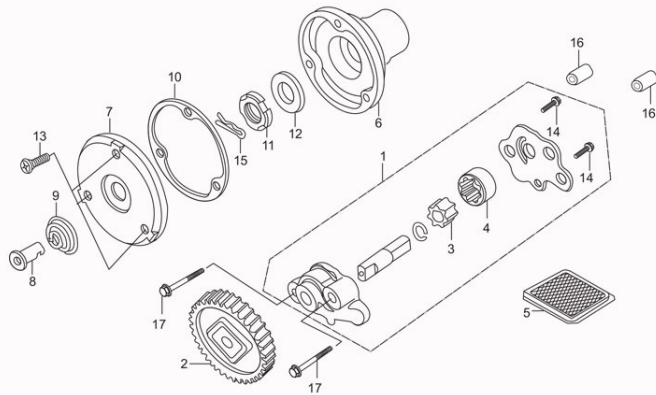

FR. 

<b>Service Item</b>	<b>F.R.T.</b>	<b>Group Number: E-8A Model :: ECO 150 (Dec, 2019)</b>			
		<b>Ref No.</b>	<b>Part Number</b>	<b>Description</b>	<b>Req.</b>
* CAP, OIL FILTER ROTOR	0.6	1	15100-KRM-840	OIL PUMP ASSY	1
* GEAR COMP., OIL PUMP DRIVE		2	15130-KRM-840	GEAR COMP., OIL PUMP	1
* SCREEN, OIL FILTER		3	15331-KRM-840	ROTOR, INNER OIL PUMP	1
* PUMP ASSY., OIL	0.7	4	15332-KRM-840	ROTOR, OUTER OIL PUMP	1
* ROTOR, OIL PUMP INNER		5	15421-KTN-900	SCREEN, OIL FILTER	1
(SAME TIME FOR TWO UNITS)		6	15430-KSP-910	ROTOR, OIL FILTER	1
		7	15436-KRM-840	CAP, OIL FILTER ROTOR	1
		8	15441-KCS-650	OIL, THROUGH	1
		9	15446-107-000	SPRING, OIL THROUGH	1
		10	15459-KWK-900	GASKET ,OIL FILTER CAP	1
		11	90231-KM7-700	NUT, LOCK, 14 MM	1
		12	90432-KPT-A00	WASHER, 14.2 X 26 X 3	1
		13	93700-05012-0A	SCREW, OVAL, 5X12	3
		14	93901-34120	SCREW, TAPPING, 4X8	2
		15	94251-08000	PIN LOCK, 8 MM	1
		16	94301-08140	DOWEL PIN, 8X14	2
		17	95701-06035-00	BOLT, FLANGE, 6X35	2

**E-9**  
CRANK SHAFT / PISTON

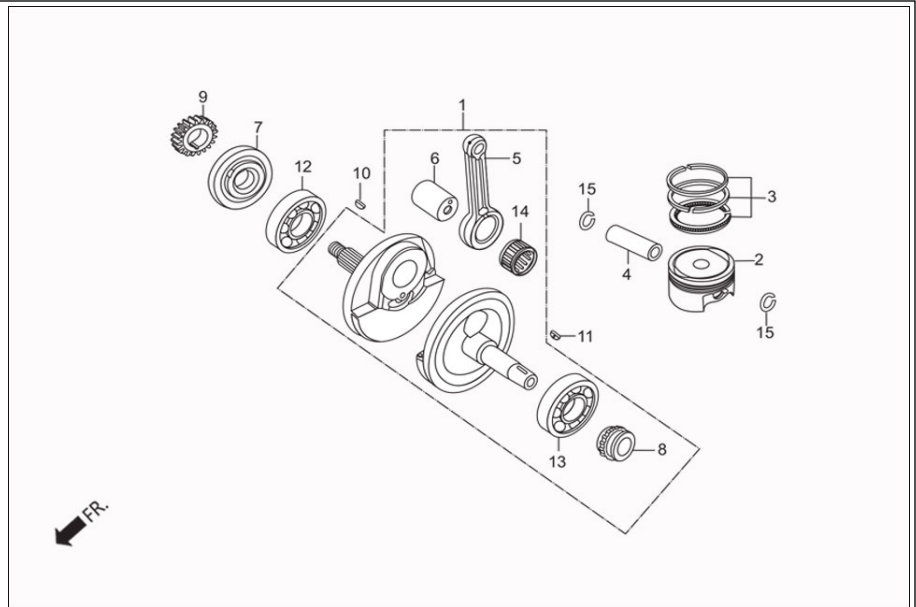



<b>Service Item</b>	<b>F.R.T.</b>	<b>Group Number: E-9 Model :: ECO 150 (Dec, 2019)</b>			
		<b>Ref No.</b>	<b>Part Number</b>	<b>Description</b>	<b>Req.</b>
* PIN, PISTON	1.7	1	13000-KSP-911	CRANK SHAFT COMP	1
* PISTON	1.8	2	13101-KSP-910	PISTON	1
* RING SET, PISTON	--		13102-KSP-305	PISTON (OS. 0.25)	1
* BEARING, ROLLER 30 X 58 X 17	*3.7		13103-KSP-305	PISTON (OS. 0.50)	1
* CRANKSHAFT COMP.,	--		13104-KSP-305	PISTON (OS. 0.75)	1
			13105-KSP-305	PISTON (OS. 1.00)	1
		3	13011-KRM-305	RING SET, PISTON (STD)	1
			13021-KRM-305	RING SET, PISTON O/S 0.25	1
			13031-KRM-305	RING SET, PISTON O/S 0.50	1
			13041-KRM-305	RING SET, PISTON O/S 0.75	1
			13051-KRM-305	RING SET, PISTON O/S 1.00	1
		4	13111-KSP-910	PIN, PISTON	1
		5	13201-KRM-840	ROD, CONNECTING	1
		6	13380-KRM-840	PIN, COMP., CRANK	1
		7	13412-KSP-910	COLLAR, R CRANK SHAFT	1
		8	14311-KRM-840	SPROCKET, TIMING, (17T)	1
		9	23121-KTN-900	GEAR, PRIMARY DRIVE, (20T)	1
		10	90741-KFB-000	KEY,WOODRUFF,4 MM	1
		11	90741-KGH-900	KEY, WOODRUFF, 4 MM	1
		12	91001-KTN-900	BRG. ROLLER, 30 X 58 X 17	1
		13	91002-KSP-911	BRG. BALL, RADIAL, 6207 SPL. L	1
		14	91101-KTN-901	BRG., NEEDLE, 28 X 36 X 15.8 (RED)	1
			91102-KTN-901	BRG., NEEDLE, 28 X 36 X 15.8 (BLUE)	1
			91103-KTN-901	BRG., NEEDLE, 28 X 36 X 15.8 (WHITE)	1
		15	94601-14000	CLIP, PISTON PIN	2

**E-9**  
CRANK SHAFT / PISTON

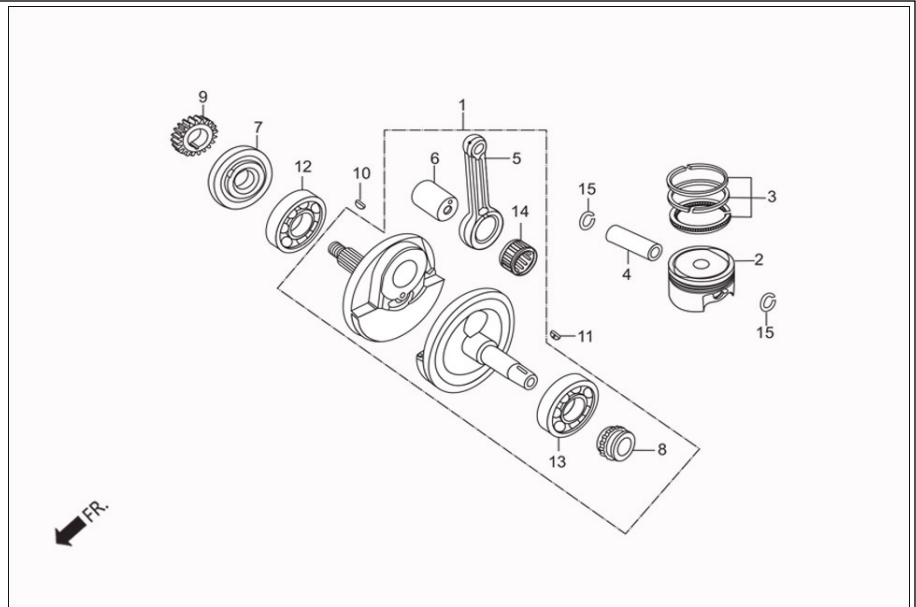

Service Item	F.R.T.
* PIN, PISTON	1.7
* PISTON	1.8
* RING SET, PISTON	--
* BEARING, ROLLER 30 X 58 X 17	*3.7
* CRANKSHAFT COMP.,	--

Group Number: E-9 Model :: ECO 150 (Dec, 2019)

SELECTION TABLE OF CONNECTING ROD BIG END BEARING						SELECTION TABLE OF CONNECTING ROD BIG END BEARING					
Crank Pin CODE (Color)	1	2	3	4	5	Crank Pin CODE (Color)	1	2	3	4	5
	-0.001 +0.001 (Green)	+0.001 +0.003 (Yellow)	+0.003 +0.005 (White)	+0.005 +0.007 (Blue)	+0.007 +0.009 (Brown)		-0.001 +0.001 (Green)	+0.001 +0.003 (Yellow)	+0.003 +0.005 (White)	+0.005 +0.007 (Blue)	+0.007 +0.009 (Brown)
Connecting rod code						Connecting rod code					
B	0.000 -0.002 91101-KTN-9000 (Red)	/	/	/	/	E	0.000 -0.002	/	/	/	91101-KTN-9000 (Red)
a	-0.002 -0.004 91102-KTN-9000 (Blue)	/	/	/	/	C	-0.002 -0.004	/	/	/	91102-KTN-9000 (Blue)
C	0.000 -0.002	0.000 -0.002 91101-KTN-9000 (Red)	/	/	/	a	-0.004 -0.006	/	/	/	91103-KTN-9000 (White)
A	-0.002 -0.004	0.000 -0.002 91102-KTN-9000 (Blue)	/	/	/	F	0.000 -0.002	/	/	/	91101-KTN-9000 (Red)
D	0.000 -0.002	/	0.000 -0.002 91101-KTN-9000 (Red)	/	/	D	-0.002 -0.004	/	/	/	91102-KTN-9000 (Blue)
B	-0.002 -0.004	/	0.000 -0.002 91102-KTN-9000 (Blue)	/	/	B	-0.004 -0.006	/	/	/	91103-KTN-9000 (White)
a	-0.004 -0.006	/	0.000 -0.002 91103-KTN-9000 (White)	/	/						

# E-10 TRANSMISSION

← FR.

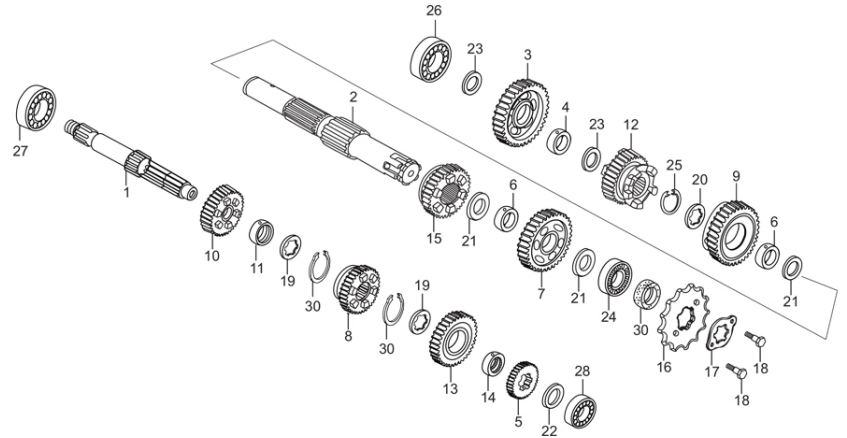

Service Item	F.R.T.	Group Number: E-10 Model :: ECO 150 (Dec, 2019)		
Ref No.	Part Number	Description	Req.	
1	23210-KVN-900	SHAFT COMP., MAIN TRANS	1	
2	23220-KTN-900	SHAFT COMP., COUNTER	1	
3	23421-KVN-900	GEAR, C-1, ( 40 T )	1	
4	23427-KRM-840	BUSH, 17 X 20.5 X 8	1	
5	23431-KVN-900	GEAR, M-2, ( 19 T )	1	
6	23432-KRM-840	BUSH, 20 MM	2	
7	23441-KVN-900	GEAR, C2, ( 34 T )	1	
8	23451-KVN-900	GEAR, M3, ( 23 T )	1	
9	23461-KVN-900	GEAR, C3, ( 30 T )	1	
10	23471-KVN-900	GEAR, M4, ( 22 T )	1	
11	23472-KSP-910	BUSH 17 MM	1	
12	23481-KVN-900	GEAR, C-4, ( 24 T )	1	
13	23491-KVN-900	GEAR, M-5, ( 32 T )	1	
14	23492-KSP-910	COLLAR SPLINE 17X20X11	1	
15	23501-KVN-900	GEAR, C-5 ( 30 T )	1	
16	23801-KSP-910	SPROCKET, DRIVE 15 T	1	
17	23811-KR3-600	PLATE, A2 FIXING	1	
18	90084-041-000	BOLT, DRIVE SPRKT, FIXING	2	
19	90452-KRM-840	WASHER ,17 X 23 X1.6	2	
20	90453-KRM-840	WASHER SPLINE 20 MM	1	
21	90454-107-000	WASHER ,THRUST, 20MM	3	
22	90456-KRM-840	WASHER, THURST, 12MM	1	
23	90452-GB4-770	WASHER, THRUST, 17MM	2	
24	91216-KSP-910	OIL SEAL	1	
25	90605-200-000	SET RING, 20MM	1	
26	91003-KSP-910	BRG. BALL RADIAL, 17 X 42 X 12	1	
27	91004-KTN-900	BRG. BALL RADIAL, 17 X 40 X 12	1	
28	91005-KTN-900	BRG. BALL RADIAL, 12 X 32 X 10	1	

29	91006-KTN-900	BRG., BALL RADIAL,20 X 47X 14	1
30	90601-AAB-A00	CIRCLIP 17 MM	1

**E-11**  
SPINDLE KICK STARTER

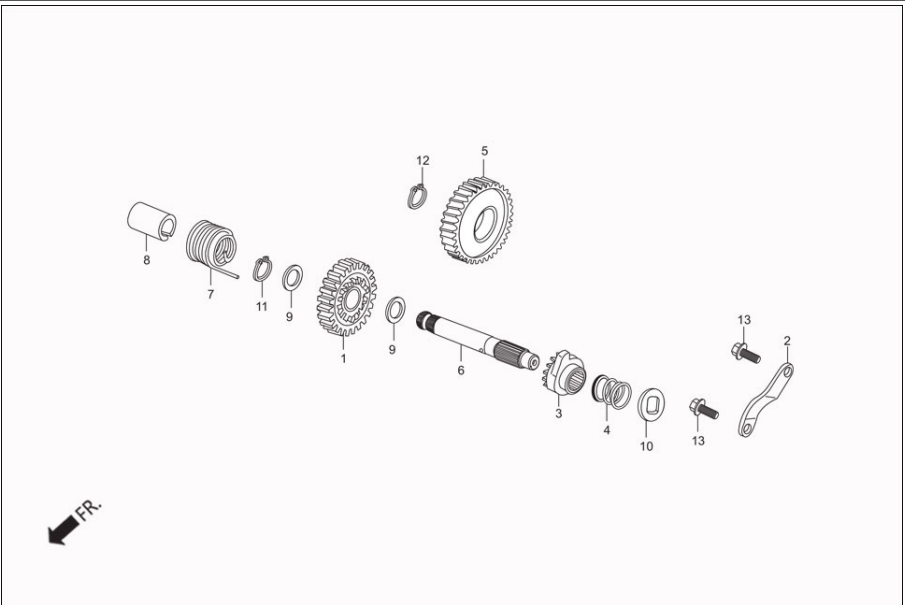

<b>Service Item</b>	<b>F.R.T.</b>	<b>Group Number: E-11 Model :: ECO 150 (Dec, 2019)</b>			
		<b>Ref No.</b>	<b>Part Number</b>	<b>Description</b>	<b>Req.</b>
* SPINDLE, KICK STARTER (INC. RELATIVE PART)	0.7	1	28211-KRM-840	PINION, KICK STARTER	1
* SPRING, KICK RETURN		2	28215-KRM-840	PLATE, KICK STOPPER	1
* GEAR, KICK STARTER IDLE	0.8	3	28221-KTN-900	RATCHET, STARTER	1
		4	28223-KRM-840	SPRING, RATCHET	1
		5	28231-KRM-840	GEAR, KICK IDLE STARTER	1
		6	28251-KTN-900	SPINDLE, KICK STARTER	1
		7	28261-KRM-840	SPG., KICK RETURN	1
		8	28282-KRM-840	COLLAR, KICK SPG.	1
		9	90451-KRM-840	WASHER, THRUST, 16 MM	2
		10	90455-KSP-910	WASHER, SPL., 14 MM	1
		11	90602-KRM-840	CIRCLIP, EXTERNAL, 17 MM	1
		12	94510-16000	CIRCLIP, EXTERNAL, 16 MM	1
		13	95701-06016-00	BOLT, FLANGE, 6X16	2



**E-12**  
DRUM GEAR SHIFT

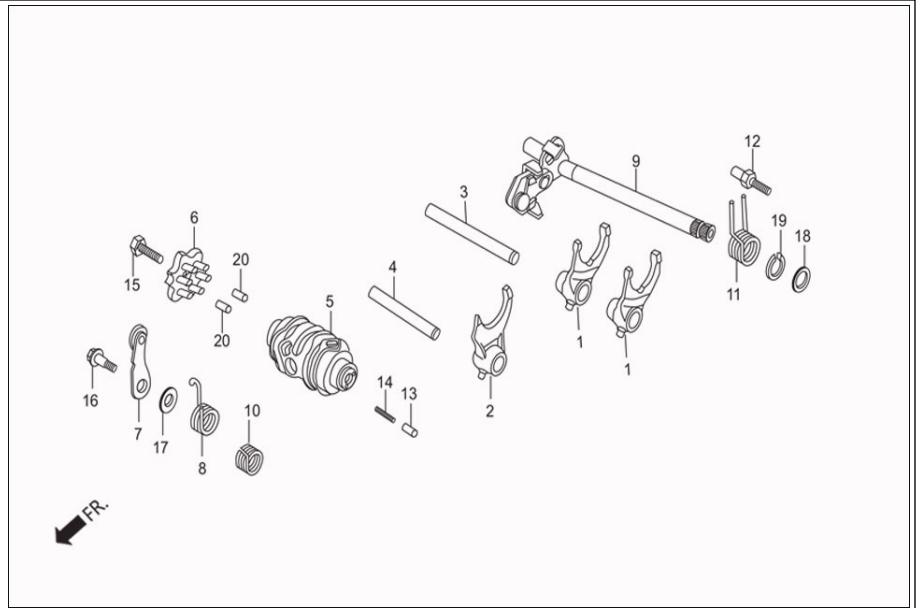

<b>Service Item</b>	<b>F.R.T.</b>	<b>Group Number: E-12 Model :: ECO 150 (Dec, 2019)</b>			
		<b>Ref No.</b>	<b>Part Number</b>	<b>Description</b>	<b>Req.</b>
* SPINDLE COMP., GEARSHIFT	0.8	1	24211-KRM-840	FORK, R/L, GEAR SHIFT	2
* PLATE COMP., SHIFT DRUM STOPPER	0.9	2	24212-KRM-840	FORK, CENTER, GEAR SHIFT	1
* STOPPER COMP., GEARSHIFT DRUM		3	24241-KRM-840	SHAFT, A GEAR SHIFT FORK	1
* DRUM, GEARSHIFT	*3.6	4	24242-KRM-840	SHAFT, B GEAR SHIFT FORK	1
* FORK, GEAR SHIFT		5	24301-KSP-910	DRUM GEAR SHIFT	1
(SAME FOR TWO UNITS OR MORE)		6	24410-KSP-910	PLATE, COMP., SHIFT DRUM STOPPER	1
		7	24430-KTN-900	STOPR COMP., GEAR SHIFT DRUM	1
		8	24436-KSP-910	SPRING, DRUM STOPPER	1
		9	24610-KSP-910	SPINDLE, COMP., GEAR SHIFT	1
		10	24627-KRM-840	SPRING GEAR SHIFTER RESET	1
		11	24651-KSP-910	SPRING, SHIFT RETURN	1
		12	24652-KSP-910	PIN, SHIFT, RETURN SPRING	1
		13	35751-KPH-900	CAP, CONTACT CHANGE SW.	1
		14	35752-KRM-840	SPRING, CONN. CHANGE SW.	1
		15	90003-KVS-900	BOLT HEX.6X20	1
		16	90022-MG8-000	PIVOT, SHIFT DRUM STOPR. ARM	1
		17	90417-KRM-840	WASHER DRUM STOPPER	1
		18	90457-KRM-840	WASHER, 14 MM	1
		19	94510-14000	CIRCLIP, EXTERNAL, 14 MM	1
		20	96220-30085	ROLLER, 3 X 8.5	2

# E-13

CARBURETTOR

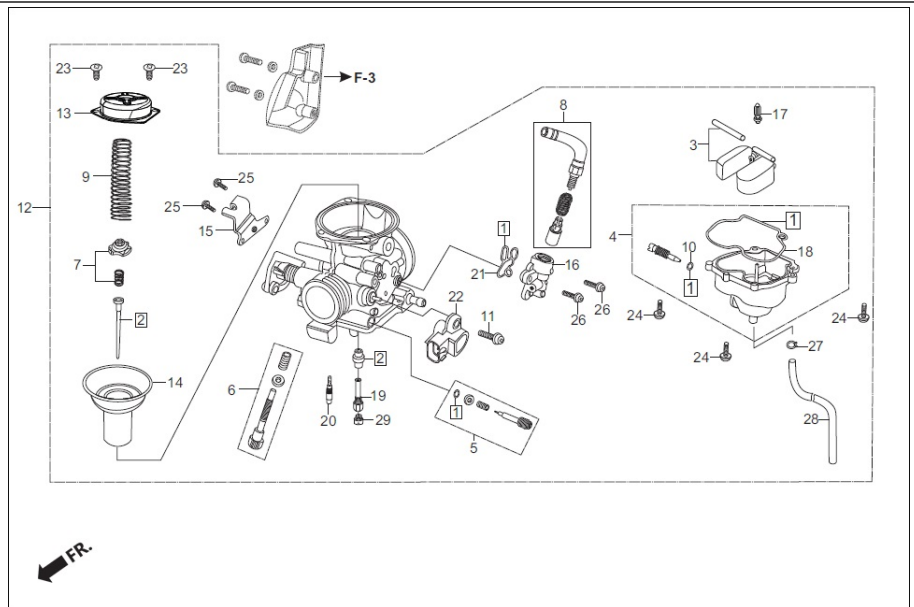

Service Item	F.R.T.	Group Number: E-13 Model :: ECO 150 (Dec, 2019)		
Ref No.	Part Number	Description	Req.	
1	16010-KSP-911	GASKET, SET	1	
2	16012-AAM-001	NEEDLE SET, JET	1	
3	16013-KRC-921	FLOAT, SET	1	
4	16015-KSP-911	CHAMBER, SET, FLOAT	1	
5	16016-KPP-901	SCREW SET, A	1	
6	16028-KPP-901	SCREW, SET, B	1	
7	16037-KPP-861	PLATE SET, VALVE	1	
8	16046-KTN-901	VALVE SET, STARTER	1	
9	16050-KTN-901	SPRING, COMPRESSION COIL	1	
10	16075-KRP-981	O-RING	1	
11	16080-KTN-901	SCREW WASH, TORX, 5X16	1	
12	16100-AAM-401	CARBURETTOR, ASSY.	1	
13	16107-KGF-901	TOP	1	
14	16111-KTN-901	PISTON COMP., VACCUM	1	
15	16119-KSP-911	STAY, WIRE	1	
16	16140-KTN-901	BODY COMP., BY-ST.	1	
17	16155-KFR-701	VALVE COMP ., FLOAT	1	
18	16163-KRP-981	GASKET, FLOAT CHAMBER	1	
19	16165-KSP-911	HOLDER, NEEDLE JET	1	
20	16180-KGF-9010	JET, SLOW, #38	1	
21	16423-KGH-901	GASKET, BY-ST	1	
22	37890-KTN-901	SENSOR ASSY., THROTTLE	1	
23	93500-04008-1A	SCREW, PAN, 4 X 8	2	
24	93500-04012-0H	SCREW, PAN 4X12	3	
25	93500-05012-0A	SCREW PAN, 5 X 12	2	
26	93892-AAR-001	SCREW WASHER , 5 X 12	2	
27	95002-02089	CLIP, B1 8 TUBE	1	
28	95005-45480-50	TUBE, 4.5X480	1	

29	99101-AAM-1100	JET MAIN # 110	1
----	----------------	----------------	---

**F-1**  
HEAD LIGHT

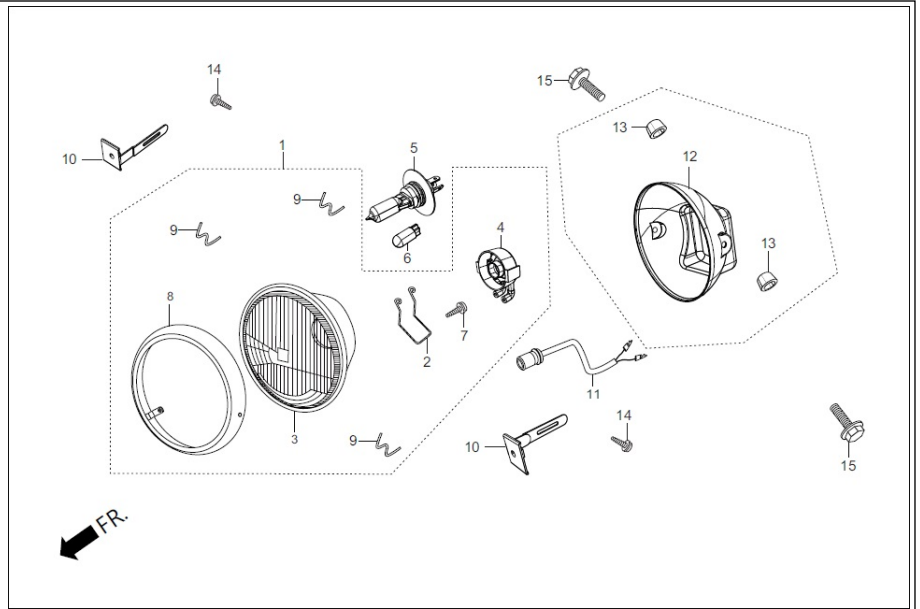

Service Item	F.R.T.	Group Number: F-1 Model :: ECO 150 (Dec, 2019)		
Ref No.	Part Number	Description	Req.	
1	3310B-AAJ-H03	LIGHT ASSY HEAD(W/O BULB)	1	
2	33108-KRY-900	SPRING, SPC(BULB HOLDER)	1	
3	33120-AAJ-H03	UNIT HEAD LIGHT	1	
4	33112-KTN-921	SOCKET COVER	1	
5	34901-KSP-910	BULB, HEAD LIGHT	1	
6	34920-AAK-201	BULB, WEDGE BASE (W3W) E MARK	1	
7	93901-04012-00	SCREW, TAPPING SPL., 4 X 12	1	
8	33101-KTN-921	RIM COMP., HEAD LIGHT	1	
9	33108-KGA-900	SPRING, UNIT HOLDER	3	
10	61303-198-D00	NUT, R HEAD LIGHT CASE	2	
11	33150-KCC-830	SOCKET ASSY., POSITION LIGHT	1	
12	6130A-AAM-310	CASE COMP HEADLIGHT (W/O VISOR)	1	
13	61302-471-000	COLLAR, HRAD LIGHT CASE	2	
14	91508-KST-940	SCREW, PAN, 5 X 14	2	
15	95701-08020-02	BOLT, FLANGE, 8 X 20	2	

**F-1VB-VISOR**  
COWL FRONT (VISOR)

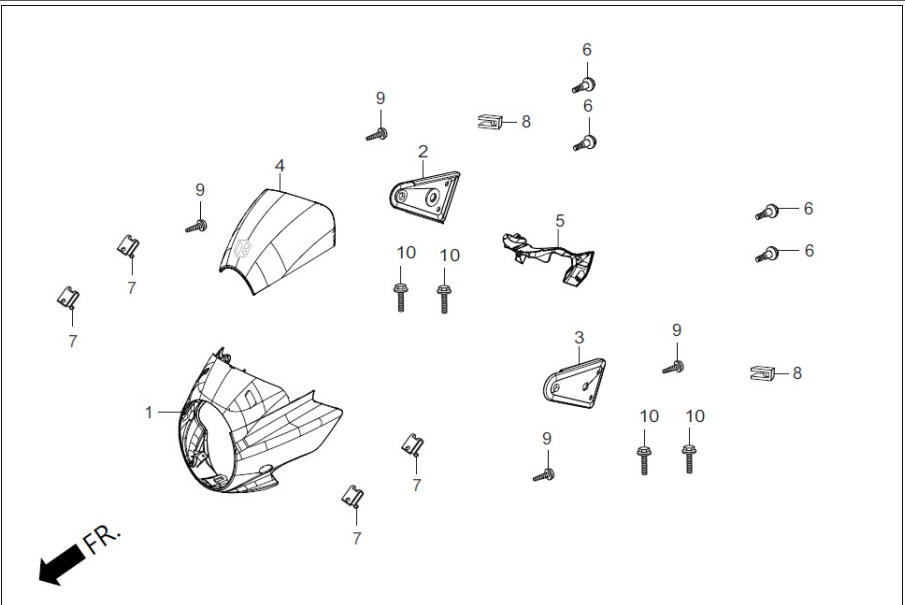



Service Item	F.R.T.	Group Number: F-1VB-VISOR Model :: ECO 150 (Dec, 2019)		
Ref No.	Part Number	Description	Req.	
1	61301-AAM-300R	SET FR. COWL (BLACK) NH-1	1	
	61301-AAM-300S	COWL FRONT(CBR R-195C)	1	
	61301-AAM-300U	SET FR. COWL (VIBRANT BLUE ME.)	1	
2	61313-AAM-310	BRKT R HEADLIGHT CASE	1	
3	61314-AAM-310	BRKT L HEADLIGHT CASE	1	
4	64100-AAG-C00R	SET, WIND SCREEN	1	
5	83402-AAM-300	PANEL INNER	1	
6	90101-GE0-000	SCREW, HINGE PATCH	4	
7	90320-GC3-000	NUT, SPRING, M5	4	
8	90810-KCC-910	RUBBER, STOPPER	2	
9	93903-34380	SCREW, TAPPING, 4X12	4	
10	96001-06012-02	BOLT FLANGE 6X12	4	

**F-1VBA-W/O VISOR**  
COWL FRONT (W/O VISOR)

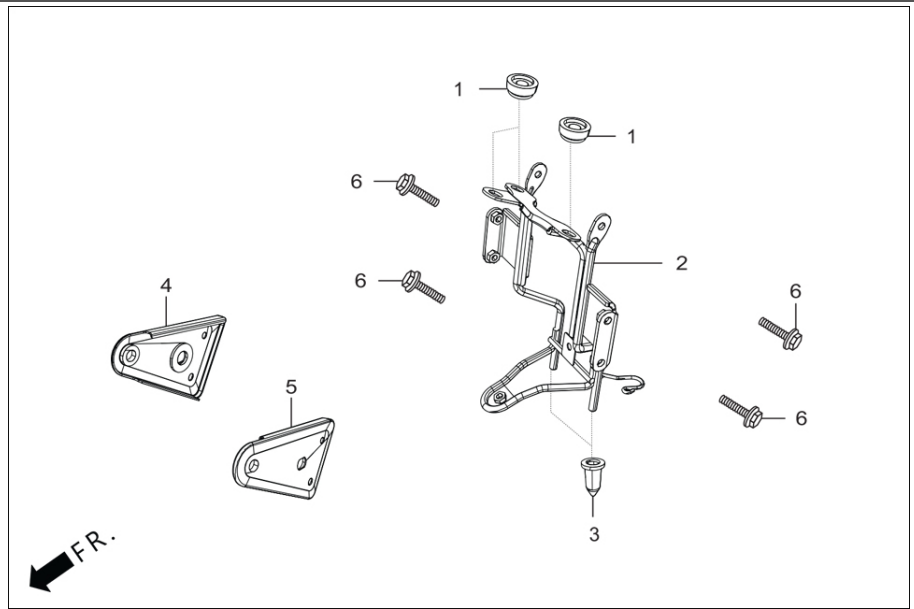

Service Item	F.R.T.	Group Number: F-1VBA-W/O VISOR Model :: ECO 150 (Dec, 2019)		
Ref No.	Part Number	Description	Req.	
1	37215-ML0-008	RUBBER, METER SET	3	
2	61311-AAM-310	STAY HEADLIGHT	1	
3	61312-KCT-690	BOOT, HEAD LIGHT STAY	2	
4	61313-AAM-300	BRKT., R HEADLIGHT CASE	1	
5	61314-AAM-300	BRKT., L HEADLIGHT CASE	1	
6	96001-06012-02	BOLT FLANGE 6X12	4	

# F-2 SPEEDOMETER

FR.

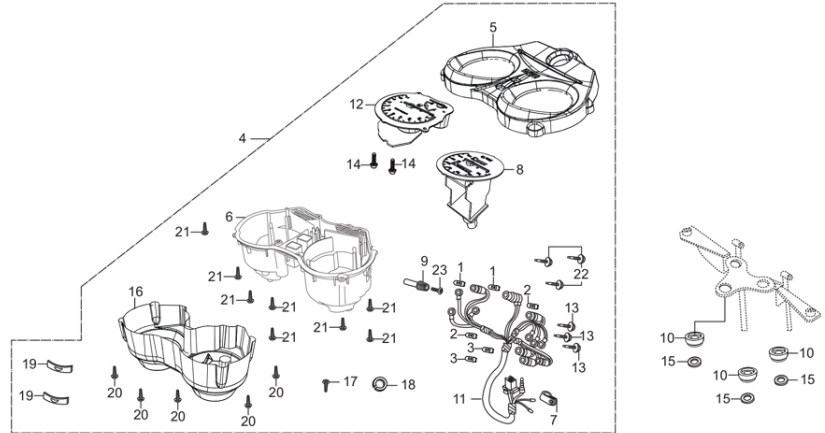

Service Item	F.R.T.	Group Number: F-2 Model :: ECO 150 (Dec, 2019)			
		Ref No.	Part Number	Description	Req.
		1	34908-KM1-671	BULB, WEDGE BASE T6.5 (12V - 3.0 W)	2
		2	34908-MB9-800	BULB, WEDGE BASE (12V - 1.7 W)	2
		3	34908-MG9-951	BULB, WEDGE BASE T6.5 (12V - 1.7 W)	2
		4	3710A-AAM-800	METER ASSY., COMB SUB. ASSY.	1
		5	37110-AAM-301	CASE, UPPER ASSY.	1
		6	37120-AAM-301	CASE, UNDER ASSY	1
		7	37121-ML7-671	CLAMP	1
		8	37200-AAM-H61	SPEEDOMETER COMP.	1
		9	37213-KY6-008	KNOB (TRIP)	1
		10	37215-ML0-008	RUBBER, METER SET	2
		11	37223-KTN-901	SOCKET, COMP.	1
		12	37250-AAM-H01	TACHO & FUEL METER ASSY.	1
		13	37305-KE5-000	SCREW, WASH, 3 X 22	3
		14	37305-MAW-621	SCREW, WASH SPL., 4X12	2
		15	90525-030-000	WASHER, PLAIN	3
		16	37618-AAM-301	COVER METER	1
		17	35305-KE5-001	SCREW PAN 3 X 22	1
		18	35305-KE5-002	SPRING WASHER 3 MM	1
		19	61306-KTN-700	CUSHION RUBBER	2
		20	90032-KW3-000	SCREW, TAPPING, 4X14	5
		21	90101-KY6-000	SCREW, TAPPING, 3X14	8
		22	90133-SL9-003	SCREW, WASH, SPL. 3X18	3
		23	90158-KM7-911	SCREW, TRIP KNOB, 2X6	1

**F-2A**  
SPEEDOMETER. CABLE

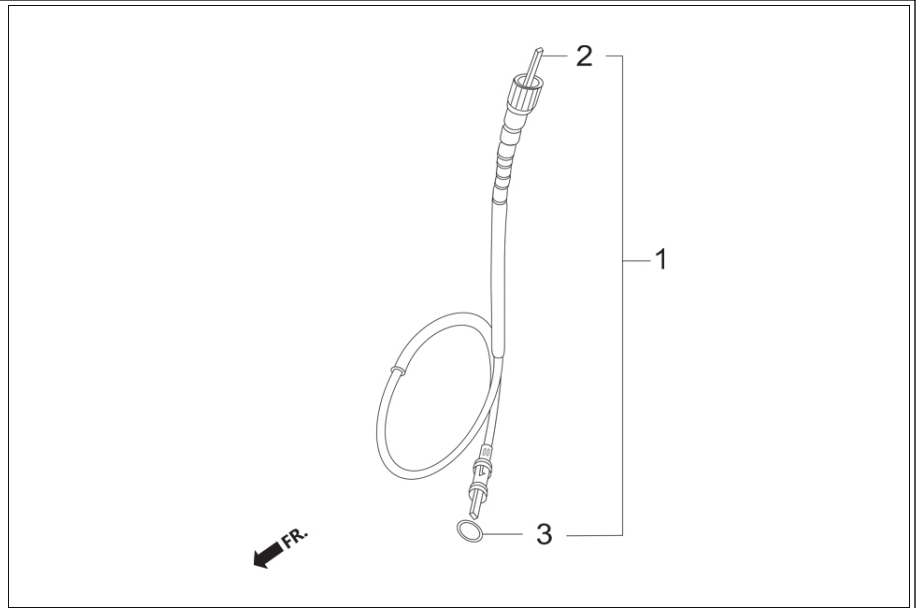

Service Item	F.R.T.	Group Number: F-2A Model :: ECO 150 (Dec, 2019)			
		Ref No.	Part Number	Description	Req.
		1	44830-KTN-950	CABLE COMP., SPEEDOMETER	1
		2	44831-KTN-950	CABLE, INNER	1
		3	91352-GAZ-930	O-RING 8.5X11.5	1

**F-3**  
HANDLE LEVER / SWITCH / CABLES

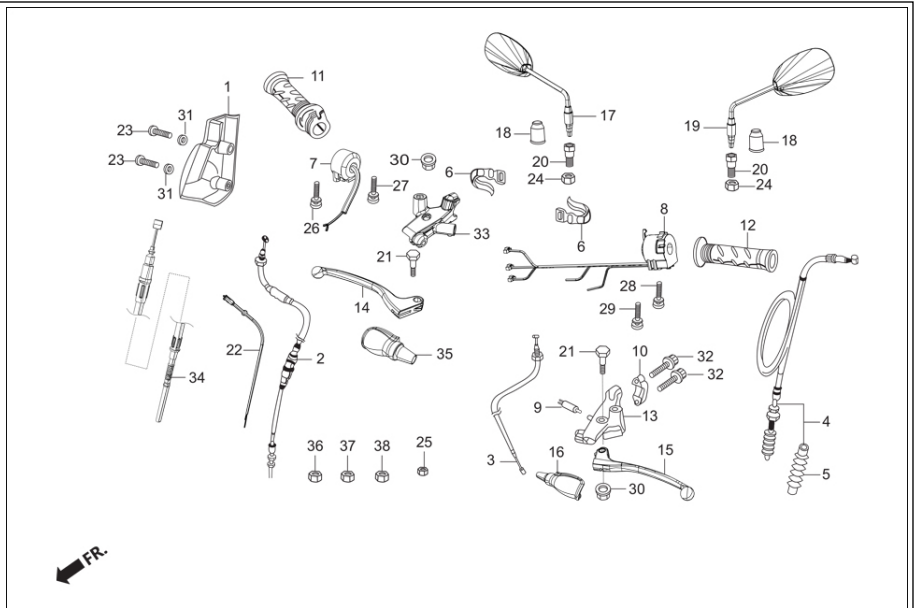

Service Item	F.R.T.	Group Number: F-3 Model :: ECO 150 (Dec, 2019)			
		Ref No.	Part Number	Description	Req.
		1	16150-KTN-700H	COVER THROTTLE CABLE	1
		2	17910-KTN-700	CABLE COMP., THROTTLE	1
		3	17950-KTN-700	CABLE COMP., CHOKE	1
		4	22870-KTN-950	CABLE COMP., CLUTCH	1
		5	22871-KTN-700	BOOT, CLUTCH CABLE	1
		6	32161-404-000	BAND B-1,WIRE	2
		7	35150-AAM-411	SW ASSY. START (DRUM)	1
		8	35200-AAM-301	SWITCH ASSY., WINKER	1
		9	35330-413-003	SW. COMP., FR. LEVER	1
		10	45517-166-000	HOLDER, MASTER CYLINDER	1
		11	53140-KFN-850	GRIP COMP., THROTTLE	1
		12	53166-KFN-850	GRIP, L HANDLE	1
		13	53172-KRC-900	BRACKET, HANDLE LEVER	1
		14	53175-AAM-300	LEVER COMP., R HANDLE	1
		15	53178-KFN-850	LEVER COMP., L HANDLE	1
		16	53182-KFN-850	BOOT, L HANDLE LEVER	1
		17	88110-AAM-100	MIRROR ASSY R BACK	1
		18	88114-KFN-950	CAP, LOCK NUT	2
		19	88120-AAM-100	MIRROR ASSY L BACK	1
		20	90003-MY5-720	BOLT,ADPT.10MM	2
		21	90113-438-000	BOLT, HANDLE LEVER PIVOT	2
		22	35340-KCC-900	SWITCH ASSY., FR. STOP	1
		23	90140-KAE-000	SCREW, PAN, 4 X 28	2
		24	90201-MW3-620	NUT, HEX., 10MM	2
		25	94002-06000-0S	NUT, HEX 6MM	2
		26	93892-05020-07	SCREW, WASHER, 5X20	1
		27	93892-05025-07	SCREW, WASHER, 5X25	1
		28	93892-05035-07	SCREW, WASHER, 5X35	1

29	93892-05045-07	SCREW, WASHER, 5X45	1
30	94050-06000	NUT, FLANGE, 6 MM	2
31	94101-04700	WASHER, PLAIN, 4 MM	2
32	96001-06022-07	BOLT, FLANGE, SH.6X22	2
33	53171-AAM-300	BRACKET, R HANDLE LEVER	1
34	45450-AAM-000	CABLE COMP.FR. BRAKE	1
35	53181-KFN-870	BOOT, R HANDLE COVER	1
36	94002-10070-0S	NUT, HEX., 10MM	1
37	94002-08000-0S	NUT HEX.8 MM	1
38	94030-08000	NUT, HEX., 8 MM	1



**F-4**  
HANDLE PIPE / TOP BRIDGE

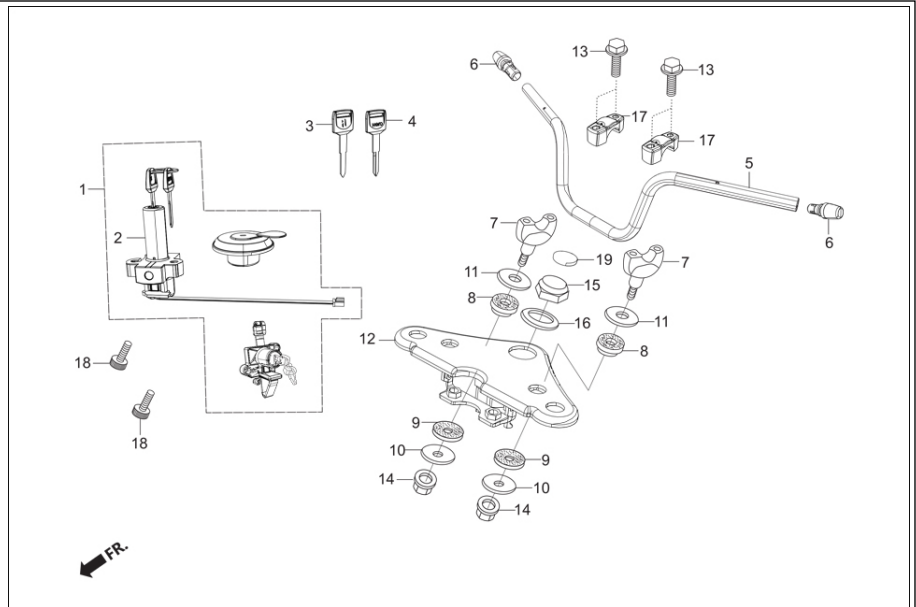

Service Item	F.R.T.	Group Number: F-4 Model :: ECO 150 (Dec, 2019)		
Ref No.	Part Number	Description	Req.	
1	35010-AAM-101	KEY SET	1	
2	35100-AAM-101	SW ASSY COMB & LOCK	1	
3	35121-AAM-H00	BLANK KEY NO.1	1	
4	35122-AAM-H00	BLANK KEY NO.2	1	
5	53100-AAM-800	PIPE, STRG. HANDLE	1	
6	53105-KRC-900	END STRG. HANDLE	2	
7	53132-124-000	HOLDER, HANDLE PIPE UNDER	2	
8	53133-198-900	RUBBER, HANDLE CUSHION UPPER	2	
9	53134-028-000	RUBBER, HANDLE CUSHION UNDER	2	
10	53135-198-900	WASHER, HANDLE CUSHION	2	
11	53136-198-900	PLATE, HANDLE CUSHION	2	
12	53230-KTN-700	BRIDGE COMP., FORK TOP	1	
13	90117-KY0-860	BOLT, FLANGE, 6X28	4	
14	90304-GA6-000	NYLOCK, NUT, 10MM	2	
15	90304-AAH-000	NUT STRG. STEM	1	
16	90503-KTR-900	WASHER, STEERING STEM	1	
17	95014-21101	HOLDER A1, HANDLE PIPE UPPER	2	
18	96700-08020-00	BOLT SOCKET, 8 MM	2	
19	53208-AAH-000	CAP STRG. STEM	1	

**F-5**  
STRG. STEM

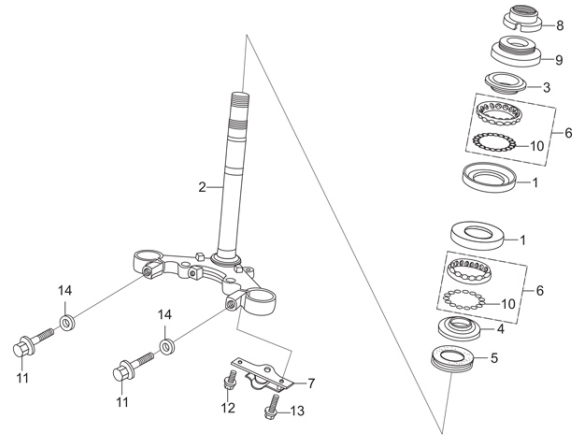

FR.

Service Item	F.R.T.	Group Number: F-5 Model :: ECO 150 (Dec, 2019)			
		Ref No.	Part Number	Description	Req.
		1	50301-KTR-900	RACE, STEERING BALL	2
		2	53200-KTN-700	STEM COMP., STRG.	1
		3	53211-268-010	RACE, STEERING TOP CONE	1
		4	53212-200-000	RACE, STEERING BOTTOM CONE	1
		5	53214-200-000	DUST SEAL, STEERING HEAD	1
		6	53215-KTR-900	BALL, ASSY. STEERING	2
		7	53216-KTN-700	PLATE, WIRE HARNESS GUIDE	1
		8	53221-KSP-900	THREAD, STRG., TOP	1
		9	53222-KRM-860	MUD GUARD, STRG., (HEAD TOP)	1
		10	96211-08000	BALL STEEL 8 MM	32
		11	95701-08035-07	BOLT, FLANGE, 8X35	2
		12	96001-06012-07	BOLT, FLANGE, SH., 6 X 12	1
		13	96001-06020-07	BOLT, FLANGE, SH. 6X20	1
		14	94101-08700	WASHER, PLAIN, 8MM	2

**F-6**  
FRONT FENDER

← FR.

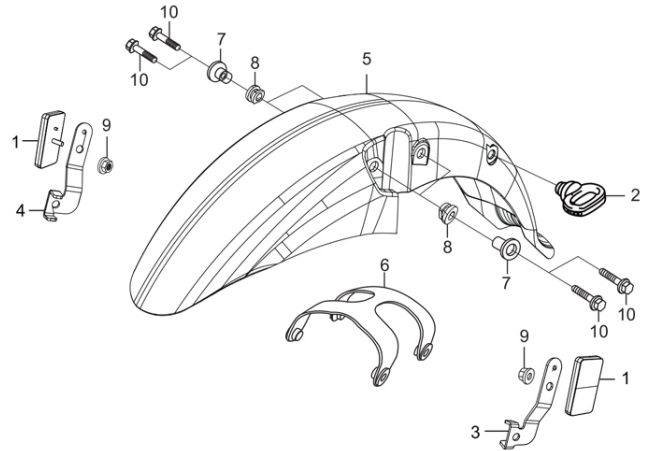

Service Item	F.R.T.	Group Number: F-6 Model :: ECO 150 (Dec, 2019)		
Ref No.	Part Number	Description	Req.	
1	33740-AAB-000	REFLEX REFLECTOR FRONT	2	
2	45451-473-000	GUIDE, FR. FENDER CABLE	1	
3	51435-AAM-400	STAY REFLECTOR L	1	
4	51436-AAM-400	STAY REFLECTOR R	1	
5	61100-AAM-500U	FR FENDER (VIBRANT BLUE ME.)	1	
	61100-KTN-700ZCH	FENDER FORNT(BLK)	1	
	61100-KTN-700ZE	FENDER, FRONT (CANDY BLAZING RED)	1	
6	61102-KTN-700	STAY, FRONT FENDER	1	
7	61103-KRY-900	COLLAR, A FR.FENDER	4	
8	61105-KTC-900	RUBBER, FRONT FENDER MOUNTING	4	
9	90302-KTE-911	NUT FLANGE PT 6MM	2	
10	96001-06035-00	BOLT, FLANGE, SH. 6 X 35	4	

**F-7**  
FRONT FORK

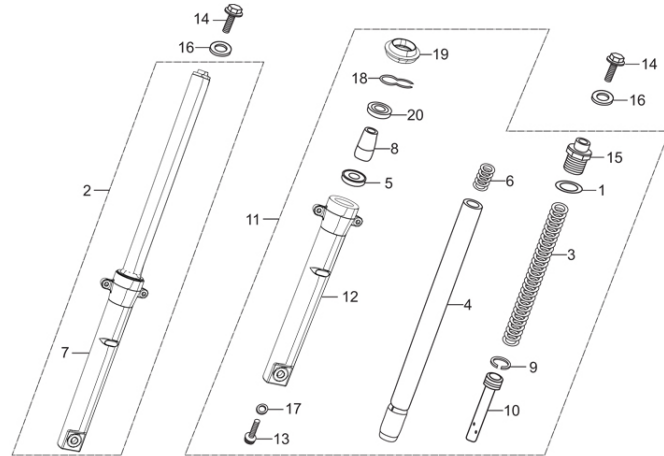

← FR.

Service Item	F.R.T.	Group Number: F-7 Model :: ECO 150 (Dec, 2019)			
		Ref No.	Part Number	Description	Req.
		1	91356-KAG-900	O - RING	2
		2	51400-AAM-000	FORK ASSY. R FRONT (DRUM)	1
		3	51401-KSP-901	SPRING, FRONT FORK	2
		4	51410-KSP-901	PIPE COMP., FR. FORK	2
		5	51412-KFN-851	SPRING, BACK UP	2
		6	51412-KSP-901	SPRING, REBOUND	2
		7	51420-AAM-000	CASE COMP. R FR BOTTOM (DRUM)	1
		8	51432-KFN-851	PIECE, OIL LOCK	2
		9	51437-KFN-851	RING, PISTON	2
		10	51440-KSP-901	PIPE, SEAT	2
		11	51500-AAM-000	FORK ASSY. L FRONT (DRUM)	1
		12	51520-AAM-000	CASE COMP. L FR BOTTOM (DRUM)	1
		13	90116-KAG-900	BOLT, SOCKET, 8 MM	2
		14	90123-KRM-860	BOLT, FR. FORK	2
		15	90123-KSP-901	BOLT, A FRONT FORK	2
		16	90521-292-000	WASHER, PLAIN, 10.3 MM	2
		17	90544-KFN-851	WASHER, SPECIAL, 8MM	2
		18	90601-KFN-851	RING, OIL SEAL STOP	2
		19	91254-GAA-003R	SEAL, DUST	2
		20	91255-GAA-003R	SEAL, OIL	2



**F-8**  
FRONT BRAKE

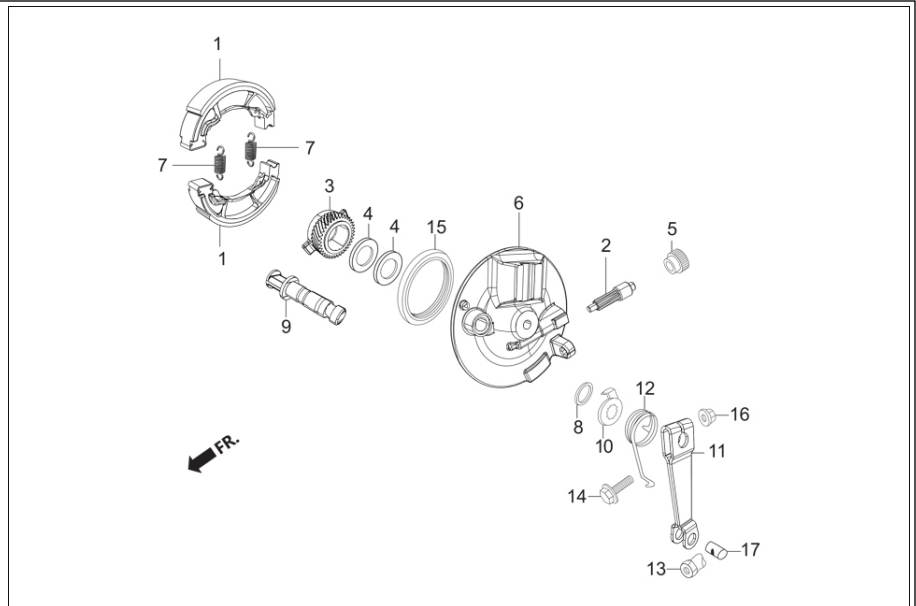

Service Item	F.R.T.	Group Number: F-8 Model :: ECO 150 (Dec, 2019)			
		Ref No.	Part Number	Description	Req.
		1	45125-AAH-F0099	SHOE COMP BRAKE	2
			45125-AAH-F0099	SHOE COMP BRAKE	2
		2	44805-KTC-900	PINION, SPEEDOMETER	1
		3	44806-KST-900	GEAR, SPEEDOMETER	1
		4	44809-170-000	WASHER, SPEEDOMETER GEAR	2
		5	44810-KTC-900	BUSH, PINION	1
		6	45010-AAM-000	PANEL SUB COMP. FR. BRAKE	1
		7	45133-KCC-900	SPRING, FR. BRAKE SHOE	2
		8	45134-250-000	DUST SEAL, BRAKE CAM	1
		9	45141-KTC-900	CAM FR. BRAKE	1
		10	45145-096-650	INDICATOR, FR. BRAKE	1
		11	45410-AAM-000	ARM FRONT BRAKE	1
		12	45435-GB2-720	SPRING, BRAKE ARM RETURN	1
		13	95015-42000	NUT B ADJUST	1
		14	95701-06032-00	BOLT, FLANGE, 6 X 32	1
		15	91251-GK4-000	OIL SEAL, 47X60X7	1
		16	94050-06000	NUT, FLANGE, 6 MM	1
		17	95015-32001	JOINT B BRAKE ARM	1

**F-9**  
FRONT WHEEL

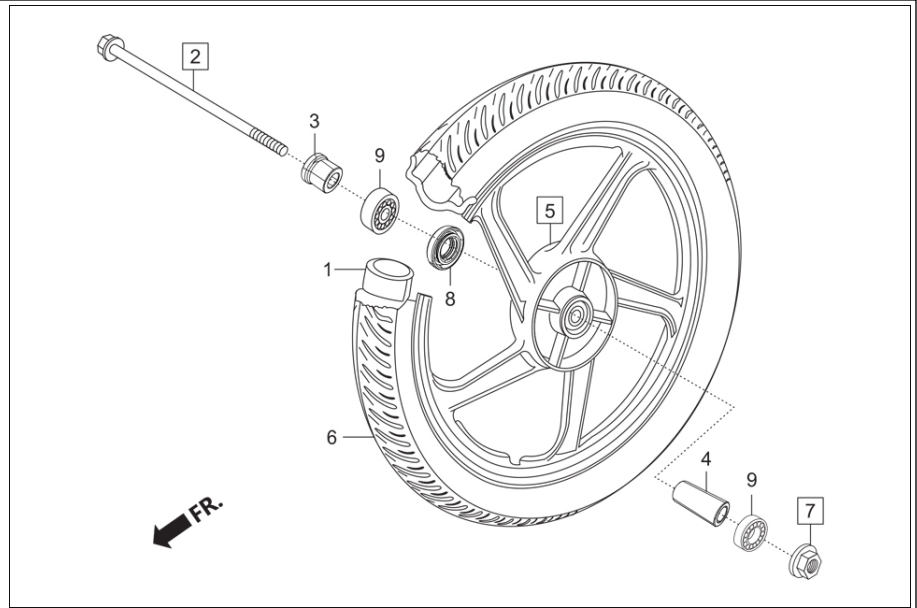

Service Item	F.R.T.	Group Number: F-9 Model :: ECO 150 (Dec, 2019)			
		Ref No.	Part Number	Description	Req.
		1	42712-KCS-920	TUBE, TYRE (2.75 X 18)	1
		2	44301-KSP-900	AXLE, FRONT WHEEL	1
		3	44311-KRC-900	COLLAR, FR. WHEEL SIDE	1
		4	44620-400-000	COLLAR, FRONT DISTANCE	1
		5	44601-AAC-H00	WHEEL COMP FRONT	1
		6	44711-KFN-850R	TYRE, FR. (2.75-18 42P)	1
		7	90306-KST-942	NUT, CASTLE, 12 MM	1
			90306-KTE-911	NUT, CASTLE, 12 MM	1
		8	91251-KPH-901	DUST SEAL, 21 X 37 X 7	1
		9	96140-63010-10	BEARING, RADIAL BALL, 6301U	2

**F-10**  
REAR BRAKE PANEL

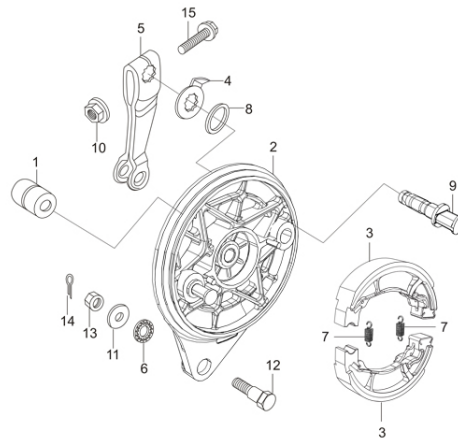

← PR.

Service Item	F.R.T.	Group Number: F-10 Model :: ECO 150 (Dec, 2019)			
		Ref No.	Part Number	Description	Req.
		1	42313-KTN-700	COLLAR, RR. BRAKE PANEL SIDE	1
		2	43100-KRY-930	PANEL COMP., RR. BRAKE	1
		3	45125-AAH-F0099	SHOE COMP BRAKE	2
			45125-AAH-F0099	SHOE COMP BRAKE	2
		4	43145-149-000	INDICATOR, RR. BRAKE	1
		5	43410-KTN-700	ARM, REAR BRAKE	1
		6	43434-ME1-670	RUBBER, STOPPER ARM	1
		7	45133-KCC-900	SPRING, FR. BRAKE SHOE	2
		8	45134-250-000	DUST SEAL, BRAKE CAM	1
		9	45141-KTC-900	CAM FR. BRAKE	1
		10	90301-473-000	NUT,U 6MM	1
		11	90505-425-000	WASHER, 8 MM	1
		12	92811-10000	BOLT A BRAKE STOPPER	1
		13	94001-08000-0S	NUT, HEX., 8 MM	1
		14	94201-20150	PIN, SPLIT, 2.0 X 15	1
		15	95701-06035-00	BOLT, FLANGE, 6X35	1



Service Item	F.R.T.	Group Number: F-11 Model :: ECO 150 (Dec, 2019)		
Ref No.	Part Number	Description	Req.	
1	41201-KSP-900	SPROCKET, FINAL DRIVEN, (42T)	1	
2	41241-KSP-900	DAMPER, RR WHEEL	4	
3	42301-KTN-700	AXLE, RR WHEEL	1	
4	42303-KRY-900	SLEEVE, RR AXLE	1	
5	42311-KRY-930	COLLAR, RR WHEEL SIDE	1	
6	42601-AAM-H50	WHEEL COMP RR	1	
7	96140-63020-10	BRG., BALL RADIAL, 6302 (U)	2	
8	96150-60050-10	BEARING, BALL RADIAL, 6005	1	
9	42611-KRY-930	FLANGE, FINAL DRIVEN(NH-35M)	1	
10	42620-KSP-900	COLLAR, REAR AXLE DISTANCE	1	
11	42711-KCC-730	TYRE, RR (3.0 X 18 - 6PR)	1	
12	42712-P11-000	TUBE, TYRE (2.75-3.0 X 18)	1	
13	90304-KCS-920	NUT U 10 MM	4	
14	90305-KVN-900	NUT, FLG. PT. 14 MM	1	
15	90559-KTN-700	WASHER, L RR. AXLE	1	
16	90560-KTN-700	WASHER, R RR. AXLE	1	
17	91253-KSP-901	DUST SEAL, 30 X 47 X 8	1	
18	91352-KSP-900	O RING, 51 X 2	1	
19	92915-10025-0E	BOLT, STUD II, 10X25	4	
20	95020-15100	NUT `E STEM	1	



**F-12**  
SEAT ASSY. /COVER FRONT

FR.

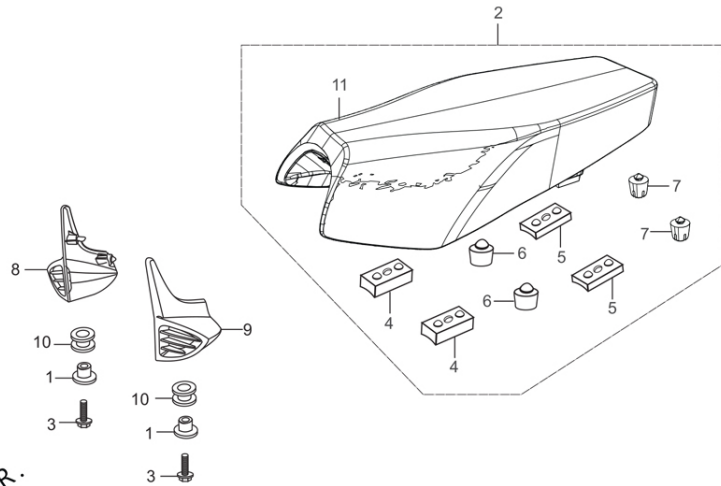

Service Item	F.R.T.	Group Number: F-12 Model :: ECO 150 (Dec, 2019)		
Ref No.	Part Number	Description	Req.	
1	19052-KV0-000	COLLAR, RADIATOR MTG	2	
2	77200-AAM-400	SEAT COMP., DOUBLE	1	
3	95701-06020-00	BOLT, FLANGE, 6X20	2	
4	77204-KTN-700	RUBBER A, SEAT SETTING	2	
5	77205-KTN-700	RUBBER B, SEAT SETTING	2	
6	77206-KTR-900	RUBBER, SEAT CUSHION	2	
7	77207-AAM-400	RUBBER SEAT CUSHION	2	
8	83100-KTN-720ZCH	COVER R FRONT(BLK)	1	
	83100-KTN-720ZEH	COVER R FRONT(CBR)	1	
	83100-KTN-H00ZF	COVER, R FRONT(VIBRANT BLUE ME)	1	
9	83200-KTN-720ZCH	COVER L FRONT(BLK)	1	
	83200-KTN-720ZEH	COVER L FRONT(CBR)	1	
	83200-KTN-H00ZF	COVER, L FRONT(VIBRANT BLUE ME)	1	
10	83545-KCJ-690	RUBBER, SIDE COVER	2	
11	7720A-AAM-300	COVER ASSY., SEAT	1	

**F-12A**  
REAR COWL

←FR.

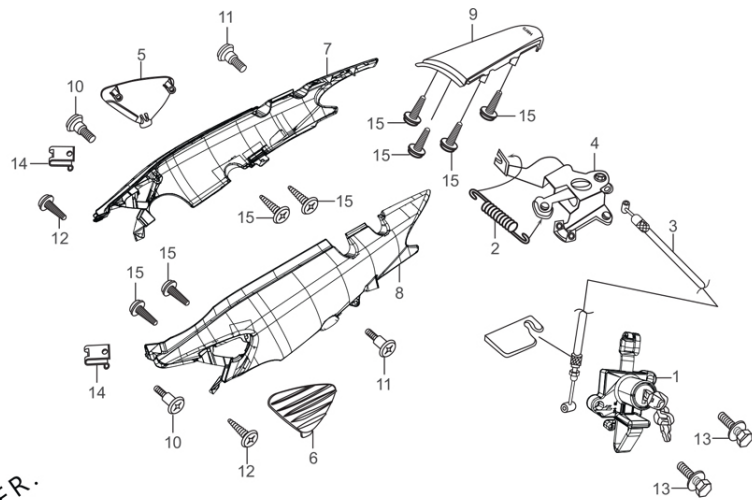

Service Item	F.R.T.	Group Number: F-12A Model :: ECO 150 (Dec, 2019)			
		Ref No.	Part Number	Description	Req.
		1	77110-KWA-H11	LOCK ASSY.,SEAT (WITH KEY)	1
		2	77151-MB1-870	SPRING, SEAT LOCK	1
		3	77156-KCT-690	CABLE, SEAT LOCK	1
		4	77160-ML7-700	BRKT. COMP., SEAT LOCK	1
		5	77215-KRC-900H	LOUVER R RR.COWL	1
		6	77225-KRC-900H	LOUVER L RR.COWL	1
		7	77246-AAM-300	COWL REAR R	1
		8	77256-AAM-300	COWL REAR L	1
		9	77280-AAM-800R	SET CENTER RR. COWL (BLACK) NH-1	1
		10	90101-GE0-000	SCREW, HINGE PATCH	2
		11	90101-087-720	SCREW, HEAD LIGHT SET	2
		12	90102-GB2-720	SCREW, PAN, 5X16	2
		13	90107-GZ4-670	BOLT, BREAK OFF	2
		14	90320-GC3-000	NUT, SPRING, M5	2
		15	93903-25210	SCREW, TAPPING, 5X12	8

**F-13**  
FUEL TANK

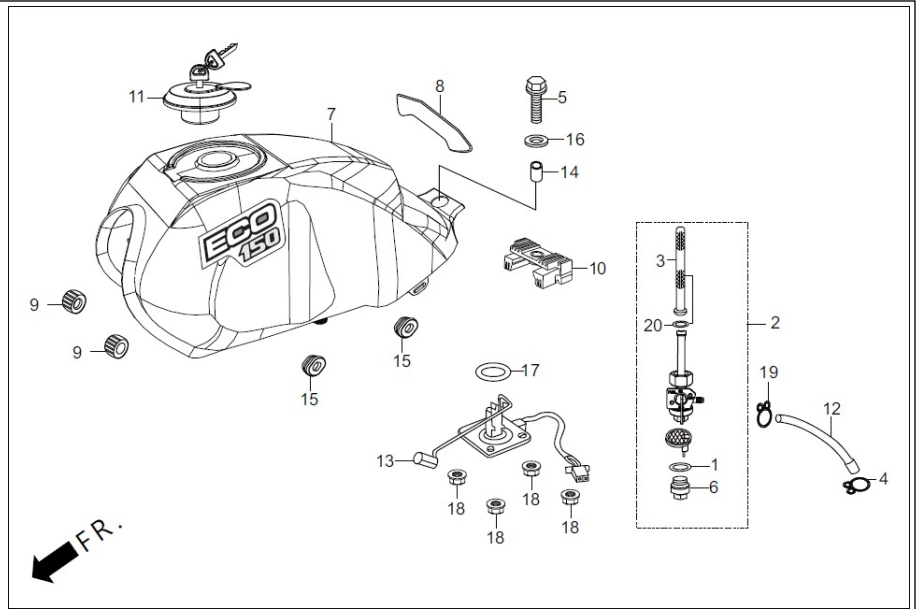

Service Item	F.R.T.	Group Number: F-13 Model :: ECO 150 (Dec, 2019)			
		Ref No.	Part Number	Description	Req.
		1	16173-001-000	O- RING	1
		2	16950-AAM-10099	COCK ASSY FUEL	1
		3	16952-KCC-900	SCREEN, FUEL STRAINER	1
		4	95002-50000	CLIP, C9 TUBE	1
		5	95701-08025-00	BOLT, FLANGE 8 X 25	1
		6	16967-MA2-770	CUP, FUEL STRAINER	1
		7	17500-AAM-A00R	SET FUEL TANK (BLACK) NH-1	1
			17500-AAM-A00S	SET FUEL TANK (CANDY BLAZING RED)	1
			17500-AAM-A00T	SET FUEL TANK (VIBRANT BLUE ME.)	1
		8	17506-KTN-700	TANK, FILM PROTECTOR	1
		9	17611-KFN-850	CUSHION, FR. FUEL TANK	2
		10	17613-MV4-000	CUSHION, RR. FUEL TANK	1
		11	17620-KST-H61	CAP COMP.FUEL FILLER	1
		12	17681-KTN-700	TUBE, FUEL	1
		13	37800-KFN-900	UNIT ASSY.,FUEL	1
		14	80101-KFN-850	COLLAR, 8X12	1
		15	83551-300-000	GROMMET, AIR CLEANER CASE	2
		16	90534-MV4-000	WASHER ,8.5X28	1
		17	91305-443-740	O RING, 39.5 X 5	1
		18	94050-06000	NUT, FLANGE, 6 MM	4
		19	95002-02080	CLIP, TUBE	1
		20	16958-397-770	O-RING	1

## F-14 SIDE COVER

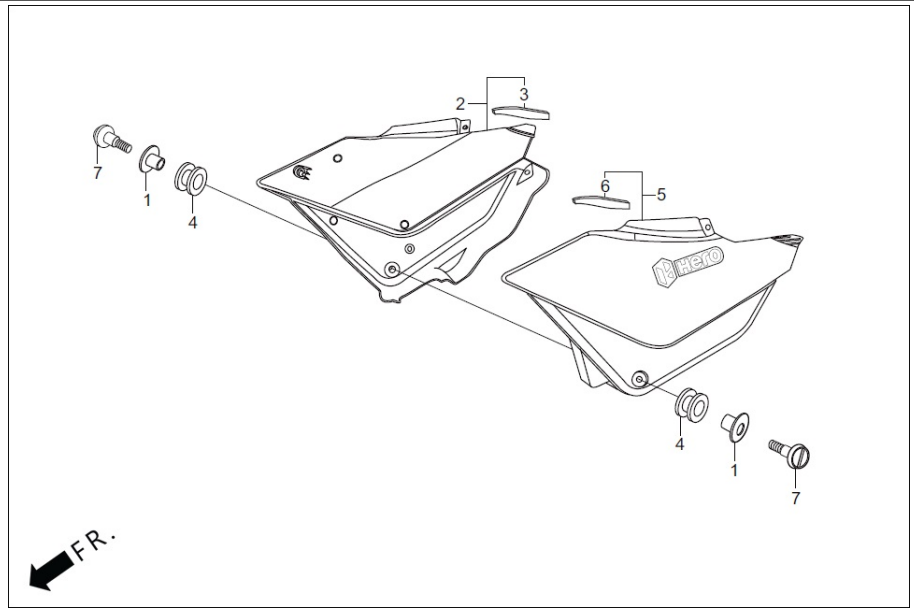

Service Item

F.R.T.

Group Number: F-14 Model :: ECO 150 (Dec, 2019)

Ref No.	Part Number	Description	Req.
1	19052-KV0-000	COLLAR, RADIATOR MTG	2
2	83500-AAM-B00R	SET R. SIDE COVER (BLACK) NH-1	1
3	83541-KTN-700	FILM, R. SIDE COVER	1
4	83545-KCJ-690	RUBBER, SIDE COVER	2
5	83600-AAM-B00R	SET L. SIDE COVER (BLACK) NH-1	1
6	83641-KTN-700	FILM, L. SIDE COVER	1
7	90105-KVN-900	BOLT, SPECIAL 6 X 22	2

# F-15 AIR CLEANER

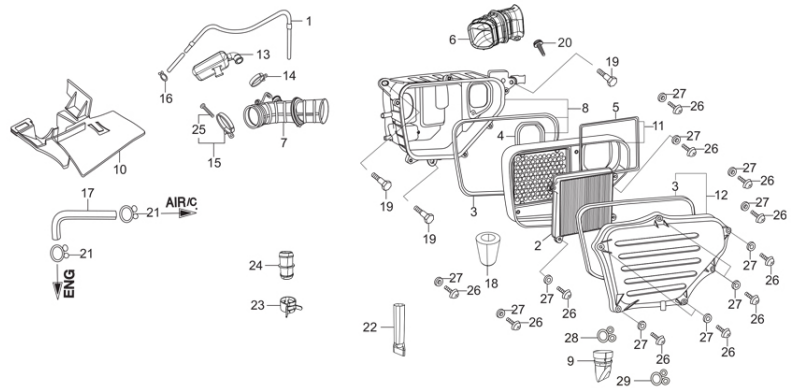

FR.



Service Item	F.R.T.	Group Number: F-15 Model :: ECO 150 (Dec, 2019)			
		Ref No.	Part Number	Description	Req.
		1	16199-KTN-700	TUBE, AIR VENT	1
		2	17211-KVN-900	ELEMENT COMP AIR/C	1
		3	17213-KRY-900	SEALA AIR CLEANER	2
		4	17214-KRY-900	SEAL B AIR CLEANER	1
		5	17215-KTN-700	SEAL, HOLDER	1
		6	17219-KTN-700H	DUCT AIR/C	1
		7	17222-KTN-700	TUBE, AIR/C CONN.	1
		8	17225-KTN-700H	CASE SUB ASSY.AIR/C	1
		9	17234-KS4-770	TUBE,AIR CLEANER DRAIN	1
		10	17234-KRC-900	COVER, AIR CLEANER DUCT	1
		11	17235-KTN-700	HOLDER SUB ASSY., AIR / CLEANER	1
		12	17245-KTN-700H	COVER SUB ASSY.AIR/C	1
		13	17311-KRC-910	RESONATOR	1
		14	17312-KFN-880	BAND, RESONATOR	1
		15	95018-52320	BAND 52 A/C CONN TUBE	1
		16	17369-AAM-100	CLIP BREATHER TUBE	1
		17	17371-KTN-700	TUBE BREATHER A	1
		18	18651-AAM-100	PLUG AIR/C	1
		19	90111-187-000	BOLT, FLANGE. 6 MM	3
		20	93500-04032-0G	SCREW, PAN, 4 X 32	1
		21	90651-MK3-780	CLIP, B 12.5 TUBE	2
		22	17216-KVN-900	TUBE, DRAIN	1
		23	91406-KFN-850	CLAMP, D14.5 TUBE	2
		24	91463-393-780	JOINT, TUBE	1
		25	93500-04025-0G	SCREW, PAN, 4X25	1
		26	93500-05016-1H	SCREW, PAN, 5 X 16	11
		27	94101-05000	WASHER , PLAIN, 5MM	11
		28	95002-70000	CLIP, C11 TUBE	1

29	95002-80000	CLIP,C12 TUBE	1
----	-------------	---------------	---

# F-16

## MUFFLER EXHAUST

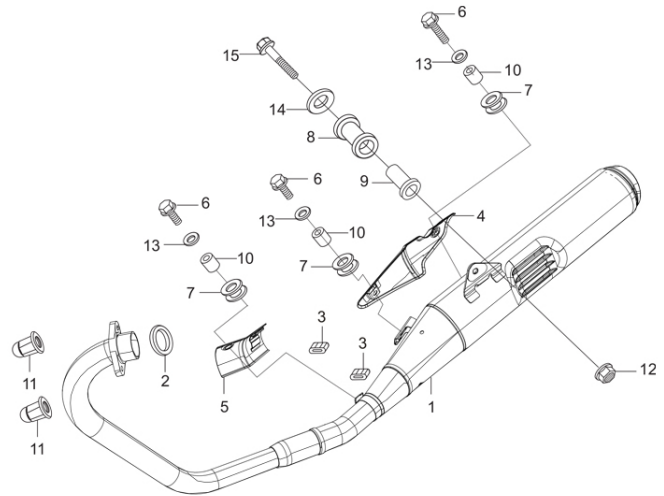

FR.

<b>Service Item</b>	<b>F.R.T.</b>	<b>Group Number: F-16 Model :: ECO 150 (Dec, 2019)</b>			
		<b>Ref No.</b>	<b>Part Number</b>	<b>Description</b>	<b>Req.</b>
*COVER-B COMP., MUFFLER	0.1	1	18300-AAM-400	MUFFLER COMP EXH	1
*MUFFLER COMP., EXHAUST	0.3	2	18291-KRY-930	GASKET, EXHAUST PIPE	1
		3	18293-KPK-900	RUBBER, PKG. PROTECTOR	2
		4	18312-AAM-300	COVER COMP MUFFLER	1
		5	18313-AAM-300	COVER, EXHAUST PIPE	1
		6	96001-06012-07	BOLT, FLANGE, SH., 6 X 12	3
		7	18345-MBT-610	RUBBER, PROTECTOR, MOUNT	3
		8	18421-438-000	RUBBER, MUFFLER MOUNT	1
		9	18442-KRC-900	COLLAR, MUFFLER MOUNT	1
		10	33619-459-840A	COLLAR,WINKER STAY	3
		11	90305-KSP-900	NUT, 8MM EXP.	2
		12	94050-10000	NUT, FLANGE, 10MM	1
		13	94101-06000	WASHER, PLAIN, 6 MM	3
		14	94103-10000	WASHER, PLAIN, 10MM	1
		15	95801-10055-00	BOLT, FLANGE, 10X55	1



<b>Service Item</b>	<b>F.R.T.</b>	<b>Group Number: F-17 Model :: ECO 150 (Dec, 2019)</b>			
		<b>Ref No.</b>	<b>Part Number</b>	<b>Description</b>	<b>Req.</b>
* BAR COMP., STEP	0.4	1	50701-AAM-3000-20	BRKT COMP R P STEP	1
* BAR R., MAIN STEP (INC. RELATIVE PART)	0.1 --	2	50603-KR0-010	PIN, MAIN STEP BAR JOINT	2
* BAR L., MAIN STEP (INC. RELATIVE PART)	0.1 --	3	50603-KFN-850	PIN, STEP BAR JOINT	2
* BRKT. COMP., R. PILLION STEP	0.5	4	50610-KTN-700	BAR COMP., STEP	1
* BRKT. L., PILLION STEP	0.2	5	50618-KE8-000	COLLAR, 6.5 X 11 X 3	4
		6	50619-AAM-100	PLATE STEP LWR	4
			50620-AAM-100	PILLION PLATE STEP LWR	4
		7	50661-AAM-100	RUBBER M STEP	4
		8	50701-KFN-850	BAR R MAIN STEP	2
		9	95701-10025-00	BOLT, FLANGE, 10 X 25	1
		10	50702-AAM-3000-20	BRKT COMP L P STEP	1
		11	50715-KFN-850	PLATE, PILLION STEP SIDE	4
		12	50801-KFN-850	BAR L MAIN STEP	2
		13	90001-KRC-900	BOLT, HEX 6 X 20	1
		14	90125-AAM-000	BOLT FLANGE TORX 10X30	1
		15	92101-06012-0G	BOLT, HEX 6 X 12	4
		16	95701-08020-00	BOLT, FLANGE, 8X20	4
		17	94102-08000	WASHER, PLAIN, 8MM	4
		18	94201-20150	PIN, SPLIT, 2.0 X 15	4

**F-18**  
PEDAL GEAR CHANGE / KICK STARTER /  
PEDAL BRAKE

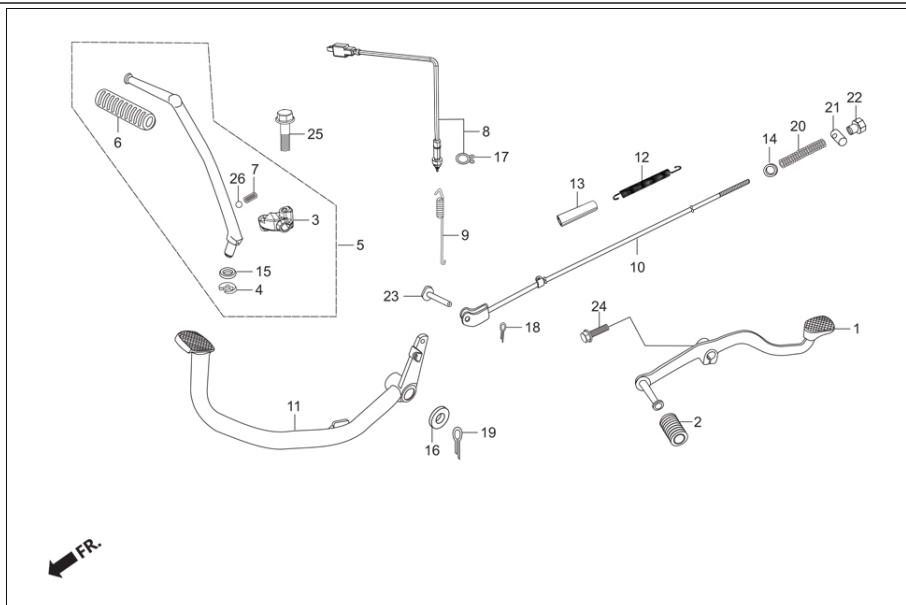

Service Item	F.R.T.	Group Number: F-18 Model :: ECO 150 (Dec, 2019)			
		Ref No.	Part Number	Description	Req.
		1	24701-KTN-700	PEDAL, GEAR CHANGE	1
		2	24781-KR3-770	RUBBER, CHANGE PEDAL	1
		3	28241-KTN-700	JOINT, KICK ARM	1
		4	28293-333-000	CLIP, KICK STARTER ARM	1
		5	28300-KTN-760	ARM ASSY., KICK STARTER	1
		6	28311-KC5-000	STARTER RUBBER, KICK	1
		7	28333-KK0-000	SPRING, KICK STARTER ARM SET	1
		8	35350-KFN-850	SW.ASSY.RR.STOP	1
		9	35357-KTN-700	SPRING STOP SWITCH	1
		10	43451-KTN-700	ROD COMP., RR BRAKE	1
		11	46500-KTN-700	PEDAL, BRAKE	1
		12	46514-KCC-900	SPRING , BRAKE PEDAL	1
		13	46515-KB9-000	TUBE , BRAKE PEDAL SPRING	1
		14	90502-198-900	WASHER , BRAKE ROD	1
		15	90505-KRM-860	WASHER, 15.5 X 22	1
		16	90521-028-000	WASHER, 17X22	1
		17	90601-KAF-003	CLIP, SW. COVER	1
		18	94201-20150	PIN, SPLIT, 2.0 X 15	1
		19	94201-30300	PIN, SPLIT 3 X 30MM	1
		20	95014-73100	SPRING A BRAKE ROD	1
		21	95015-32001	JOINT B BRAKE ARM	1
		22	95015-42000	NUT B ADJUST	1
		23	95015-53000	PIN, C JOINT	1
		24	95701-06020-00	BOLT, FLANGE, 6X20	1
		25	95801-08035-00	BOLT FLANGE 8X35	1
		26	96211-08000	BALL STEEL 8 MM	1



**F-18A**  
MAIN STAND / SIDE STAND

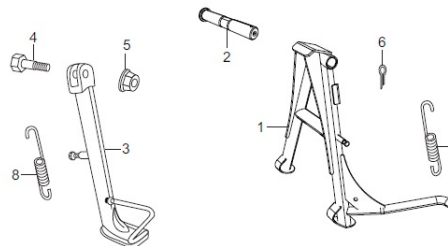

Service Item

F.R.T.

Group Number: F-18A Model :: ECO 150 (Dec, 2019)

Ref No.	Part Number	Description	Req.
1	50500-KVE-930	STAND COMP. MAIN	1
2	50526-KCT-690	SHAFT, MAIN STAND PIVOT	1
3	50530-KTN-700	BAR COMP., SIDE STAND	1
4	90107-GN1-010	SCREW SIDE STAND PIVOT	1
5	90304-KFN-850	NUT U 10 MM	1
6	94201-30300	PIN, SPLIT 3 X 30MM	1
7	95014-71702	SPRING G MAIN STAND	1
8	95014-72102	SPRING, SIDE STAND	1

**F-19**  
SWINGARM / CHAIN CASE

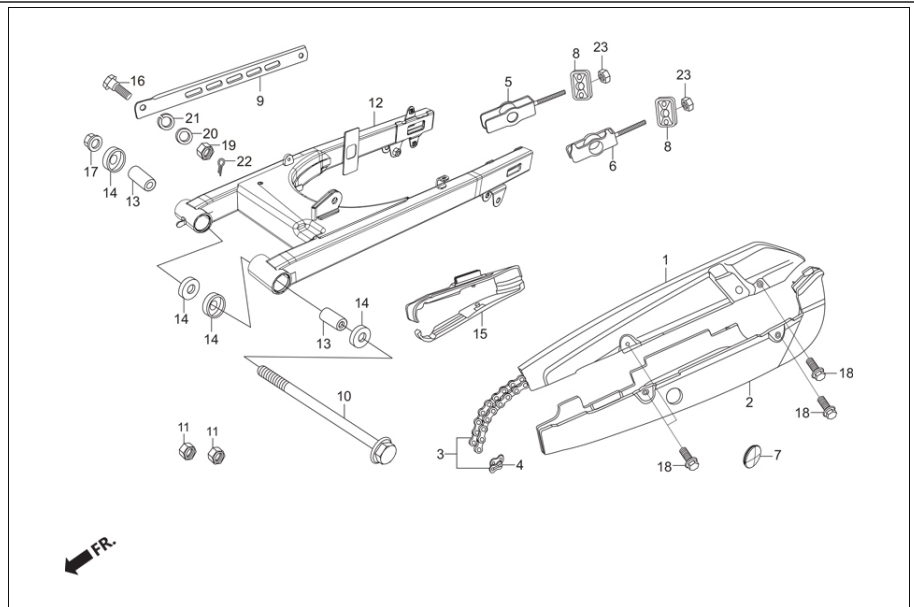

Service Item	F.R.T.	Group Number: F-19 Model :: ECO 150 (Dec, 2019)			
		Ref No.	Part Number	Description	Req.
		1	40510-KTN-760	CASE, UPPER HALF DRIVE CHAIN	1
		2	40520-KTN-760	CASE, UNDER HALF DRIVE CHAIN	1
		3	40530-KTN-700	CHAIN, DRIVE, 428H - 120	1
		4	40531-KCS-690	JOINT, RJ. DRIVE CHAIN	1
		5	40543-KTN-700	ADJUSTER, R CHAIN	1
		6	40544-KTN-700	ADJUSTER, L CHAIN	1
		7	40545-001-000	CAP, CHAIN PEEP HOLE	1
		8	40546-KTN-700	CAP, SWINGARM END	2
		9	43431-KTN-700	ARM, RR BRAKE STOPPER	1
		10	52101-KTN-700	BOLT, SWINGARM PIVOT	1
		11	94001-10000-0S	NUT, HEX., 10 MM	2
		12	52110-AAM-000	SWINGARM COMP., RR	1
		13	52141-KTN-700	COLLAR, SWINGARM (PIVOT)	2
		14	52144-KEJ-900	DUST SEAL, CAP REAR SWINGARM	4
		15	52170-KTN-700	SLIDER, CHAIN	1
		16	90133-331-770	BOLT, HEX., 8MM	1
		17	90305-KVN-900	NUT, FLG. PT. 14 MM	1
		18	95701-06012-00	BOLT, FLANGE, 6X12	4
		19	94001-08000-0S	NUT, HEX., 8 MM	1
		20	94101-08000	WASHER, PLAIN, 8MM	1
		21	94111-10000	WASHER, SPRING, 10MM	1
		22	94201-20150	PIN, SPLIT, 2.0 X 15	1
		23	94001-06000-0S	NUT, HEX., 6 MM	2

# F-20

## CUSHION REAR

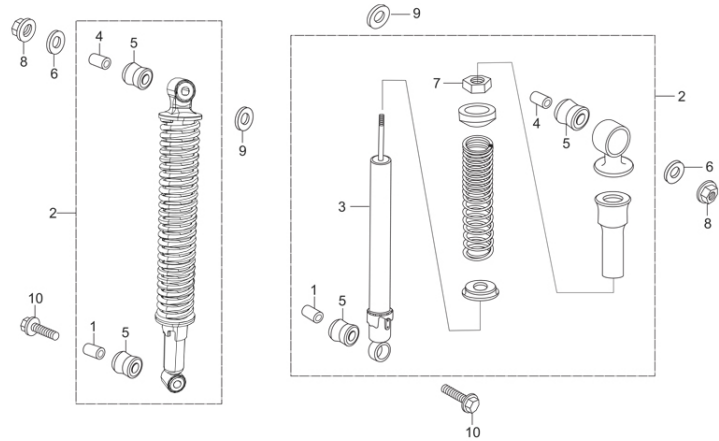

←FR.

Service Item	F.R.T.	Group Number: F-20 Model :: ECO 150 (Dec, 2019)			
		Ref No.	Part Number	Description	Req.
		1	51488-KTN-701	COLLAR, RUBBER BUSH (UNDER)	2
		2	52400-AAM-300	CUSHION ASSY., REAR	2
		3	52410-KTN-701	DAMPER COMP. , REAR	2
		4	52486-KTN-701	COLLAR, RUBBER BUSH (UPPER)	2
		5	52489-399-600	BUSH ,RUBBER (UPPER)	4
		6	90551-178-000	WASHER,SPL., 10MM	2
		7	94002-10000-0S	NUT, HEX, 10MM	2
		8	94050-10000	NUT, FLANGE, 10MM	2
		9	94101-12800	WASHER,PLAIN ,12 MM	2
		10	95801-10035-00	BOLT, FLANGE, 10X35	2

**F-21**  
REAR FENDER

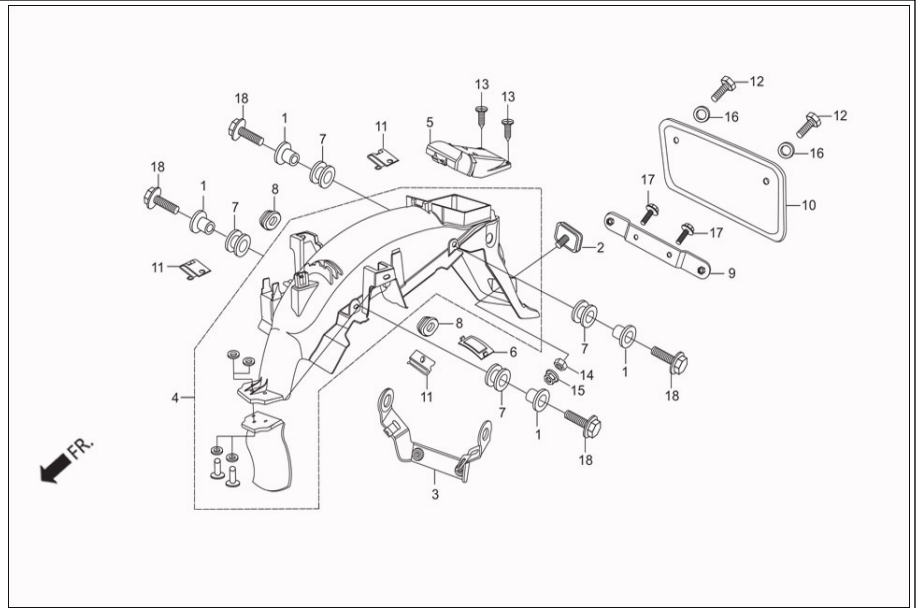

<b>Service Item</b>	<b>F.R.T.</b>	<b>Group Number: F-21 Model :: ECO 150 (Dec, 2019)</b>			
		<b>Ref No.</b>	<b>Part Number</b>	<b>Description</b>	<b>Req.</b>
* COVER, TOOL BOX	0.5	1	19052-KV0-000	COLLAR, RADIATOR MTG	4
* FENDER COMP., REAR	0.6	2	33741-AAM-101	REFLEX REFLECTOR	1
		3	50186-KTN-700	STAY, REAR WINKER	1
		4	80100-KTN-700	FENDER COMP., REAR	1
		5	80102-AAM-300	COVER, TOOL BOX	1
		6	80130-KRC-900	CAP, REAR FENDER	1
		7	83545-KCJ-690	RUBBER, SIDE COVER	4
		8	83551-GE2-000	GROMMET, AIR CLENER CASE	2
		9	84701-KCC-860	BRACKET, NUMBER PLATE	1
		10	84701-P26-D00A	NUMBER, PLATE REAR	1
		11	90320-GC3-000	NUT, SPRING, M5	3
		12	92000-06012-0A	BOLT,HEX.,6X12	2
		13	93903-25220	SCREW, TAPPING, 5X12	2
		14	94001-06000-0S	NUT, HEX., 6 MM	1
		15	94050-06000	NUT, FLANGE, 6 MM	1
		16	94101-06000	WASHER, PLAIN, 6 MM	2
		17	95701-06012-00	BOLT, FLANGE, 6X12	2
		18	95701-06020-00	BOLT, FLANGE, 6X20	4

**F-22**  
**WINKER**

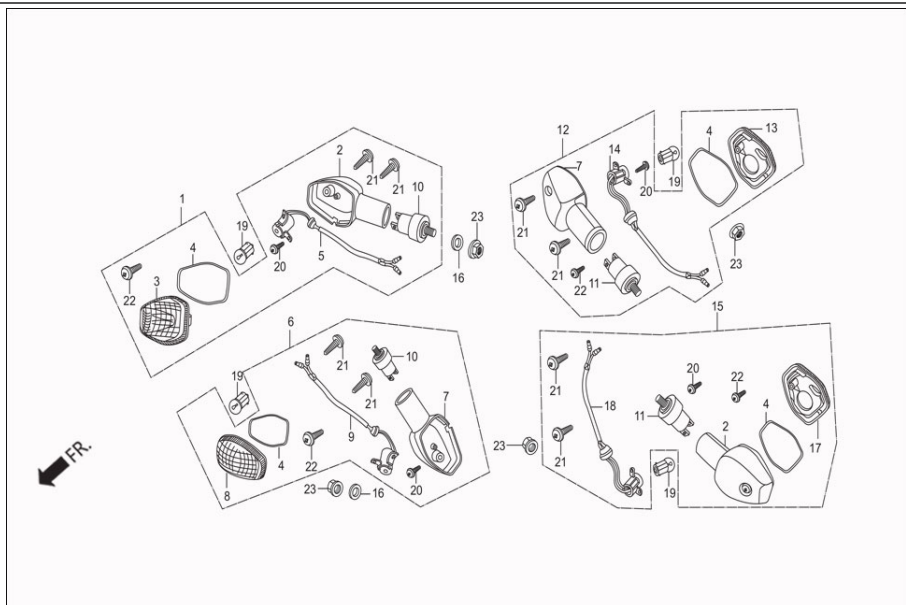



<b>Service Item</b>	<b>F.R.T.</b>	<b>Group Number: F-22 Model :: ECO 150 (Dec, 2019)</b>			
		<b>Ref No.</b>	<b>Part Number</b>	<b>Description</b>	<b>Req.</b>
* WINKER ASSY., R/L FR	0.2	1	3340A-AAM-301	WINKER ASSY R FR(W/O BULB)	1
(ADD 0.1 FOR EACH.)	--	2	33401-KTR-901	BASE WINKER R	2
(INC. RELATIVE PART)	--	3	33403-AAM-101	LENS COMP., R WINKER	1
* WINKER ASSY., R/L RR	0.3	4	33406-KTR-901	SEAL, GASKET.	4
(ADD 0.1 FOR EACH.)	--	5	33415-AAM-301	SOCKET COMP., R WINKER	1
(INC. RELATIVE PART)	--	6	3345A-AAM-301	WINKER ASSY., L FR	1
(EXC. RELATED PARTS BELOW)	--	7	33451-KTR-901	BASE WINKER L	2
* BULB, WINKER	0.1	8	33453-AAM-101	LENS COMP., L WINKER	1
(WHEN SERVICING COMP., UNIT,	--	9	33465-AAM-301	SOCKET COMP., L WINKER	1
F.R.T. IS 0.2)	--	10	33491-KAF-000	STAY COMP., WINKER	2
		11	33491-KRC-900	STAY COMP., WINKER	2
		12	3360A-AAM-301	WINKER ASSY., R RR	1
		13	33603-AAM-101	LENS COMP., R WINKER	1
		14	33615-AAM-301	SOCKET COMP., R WINKER	1
		15	3365A-AAM-301	WINKER ASSY., L RR	1
		16	33650-KAF-000	COLLAR FR. WINKER LIGHT	2
		17	33653-AAM-101	LENS COMP., L WINKER	1
		18	33665-AAM-301	SOCKET COMP., L WINKER	1
		19	34904-AAM-301	BULB, WINKER LIGHT, (R10W)	4
		20	90380-MB2-000	SCREW, SPECIAL, 6 X 8	4
		21	93901-22310	SCREW, TAPPING, 3 X 12	8
		22	93903-34480	SCREW, TAPPING, 4X 16	4
		23	94050-10000	NUT, FLANGE, 10MM	4

**F-23**  
TAIL LIGHT

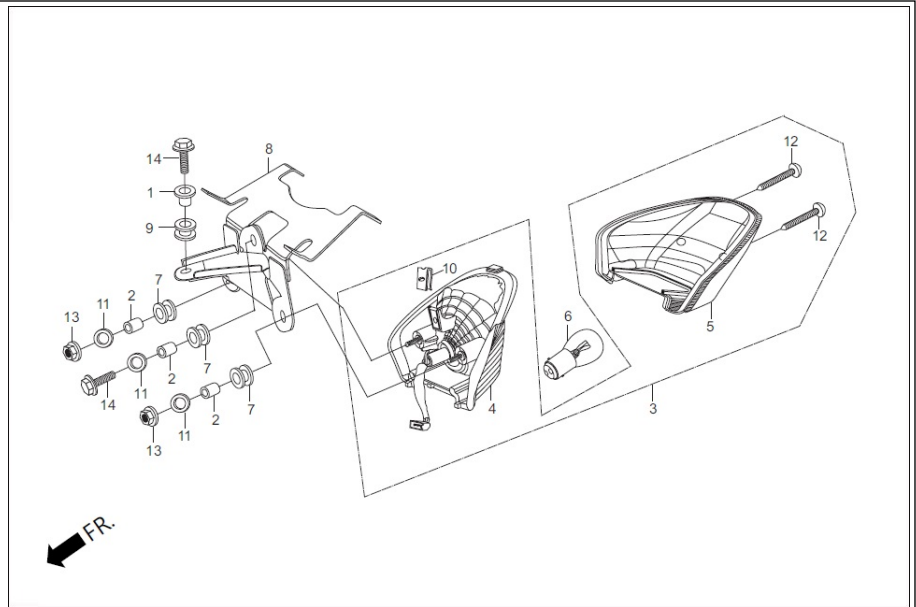

Service Item	F.R.T.	Group Number: F-23 Model :: ECO 150 (Dec, 2019)			
		Ref No.	Part Number	Description	Req.
		1	19052-KV0-000	COLLAR, RADIATOR MTG	1
		2	33603-053-650	COLLAR, RR. WINKER	3
		3	3370A-AAM-301	UNIT, TAIL LIGHT	1
		4	33703-AAM-301	BASE COMP., TAIL LIGHT	1
		5	33704-AAM-101	LENS COMP., TAILLIGHT	1
		6	34906-AAN-601	BULB TAIL & STOP (12V-21/5W)E-MARK	1
		7	77209-KAG-900	RUBBER, SEAT STAY MOUNT	3
		8	77235-KRC-900	STAY, TAIL LIGHT	1
		9	83545-KCJ-690	RUBBER, SIDE COVER	1
		10	90344-KEV-900	NUT C CLIP 6MM	1
		11	90563-355-000	WASHER, WHEEL, 6 MM	3
		12	93901-34680	SCREW, TAPPING, 4X25	2
		13	94050-06000	NUT, FLANGE, 6 MM	2
		14	95701-06022-00	BOLT, FLANGE, SH. 6 X 22	2



Service Item	F.R.T.	Group Number: F-24 Model :: ECO 150 (Dec, 2019)			
		Ref No.	Part Number	Description	Req.
		1	30401-KTN-901	CUSHION, CDI UNIT	1
		2	30410-KTN-901	UNIT COMP., DIGITAL DC CDI	1
		3	30500-KTN-900	COIL ASSY., IGNITION	1
		4	30604-KFL-D21	CAP,CORD WATER PROOF	1
		5	30605-KE2-940	SEAL, HIGH TENSION TERMINAL	1
		6	30700-KJ9-020	CAP,ASSY.,NOISE SUPPRESSOR	1
		7	31600-AAM-801	REG., REC. COMP.	1
		8	31700-124-000	RECTIFIER ASSY., SILICON	1
		9	32100-AAM-A00	HARNESS, WIRE	1
		10	32401-KTN-900	CABLE, ST.MAG. BATT	1
		11	32406-KAZ-000	COVER, ST.MAG.TERMINAL	1
		12	32410-KTN-900	CABLE, START MOTOR	1
		13	32411-253-000	COVER, STARTING MOTOR	1
		14	32414-KRC-900	COVER, BATTERY TERMINAL	1
		15	32601-KTN-900	CABLE, BATTERY EARTH	1
		16	32602-KTN-900	CABLE, ENGINE EARTH	1
		17	35850-KR3-870	SWITCH ASSY., START MAG.	1
			35850-AAM-H01	SW ASSY. START MAG	1
		18	35856-MBG-003	RUBBER, SHOCK	1
		19	95701-06016-00	BOLT, FLANGE, 6X16	1
		20	38301-KK4-010	RELAY COMP., WINKER	1
		21	38306-GE7-000	SUSPENSION, WINKER RELAY	1
		22	98200-31500	BLADE, FUSE, 15A	2
		23	98200-32000	BLADE, FUSE, 20A	2
		24	90111-MR5-000	BOLT, SOCKET, 5X9	2
		25	91547-SF4-003	BAND,HARN	1
		26	93500-05020-0A	SCREW PAN 5X20	2
		27	32108-197-000	COVER, A CONNECTOR	1

# F-24A BATTERY ASSY

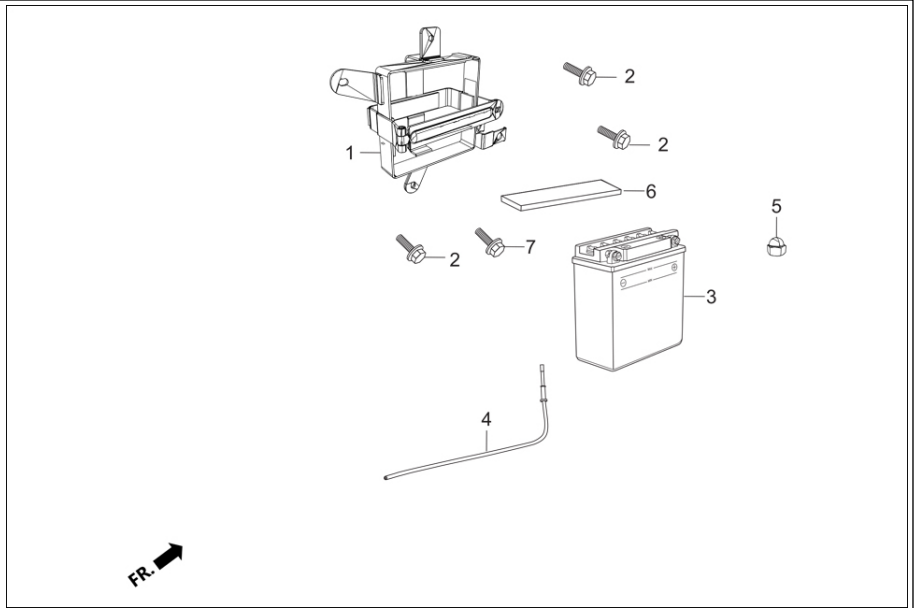

Service Item

F.R.T.

Group Number: F-24A Model :: ECO 150 (Dec, 2019)

Ref No.	Part Number	Description	Req.
1	17232-KTN-900	CASE COMP., BATTERY	1
2	95701-06016-00	BOLT, FLANGE, 6X16	3
3	31500-KCT-691	BATTERY ASSY.	1
4	31502-KRC-760	TUBE, BATTERY BREATHER	1
5	94021-06090-0S	NUT, HEX CAP 6MM	1
6	50383-KRC-900	RUBBER , BATTERY	1
7	95701-06008-00	BOLT, FLANGE, 6X8	1

**F-25**  
FRAME BODY / GRIP REAR

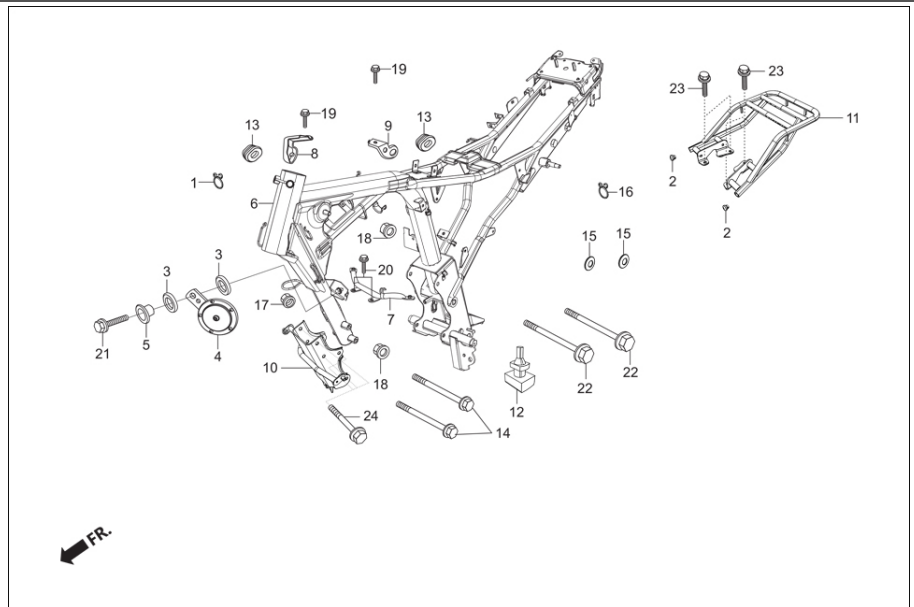

Service Item	F.R.T.	Group Number: F-25 Model :: ECO 150 (Dec, 2019)			
		Ref No.	Part Number	Description	Req.
		1	15772-KTN-900	CLIP BREATHER TUBE	1
		2	84103-KCC-900	CAP, CARRIER RR.	2
		3	33714-KL3-620	RUBBER, TAIL LIGHT	2
		4	38110-AAB-401	HORN COMP	1
		5	38117-KFE-701	COLLAR, HORN SET	1
		6	50100-AAM-400	FRAME BODY COMP.,	1
		7	50169-KTN-700	STAY, C FRONT COVER	1
		8	50172-KTN-700	STAY, B RIGHT FRONT COVER	1
		9	50173-KTN-700	STAY, B LEFT FRONT COVER	1
		10	50351-KVE-900	PLATE, FRONT ENGINE HANGER	1
		11	81200-AAM-400	CARRIER COMP. REAR	1
		12	50505-KTN-700	RUBBER, A STAND STOPPER	1
		13	83551-300-000	GROMMET, AIR CLEANER CASE	2
		14	90019-399-010	BOLT, FLANGE, 10 X 110	2
		15	90417-KRM-840	WASHER DRUM STOPPER	2
		16	90651-MK3-780	CLIP, B 12.5 TUBE	1
		17	94050-08000	NUT, FLANGE, 8MM	3
		18	94050-10000	NUT, FLANGE, 10MM	2
		19	95701-06012-00	BOLT, FLANGE, 6X12	2
		20	95701-06014-00	BOLT, FLANGE, 6 X 14	2
		21	95701-06020-07	BOLT, FLANGE, 6 X 20	1
		22	95801-08085-00	BOLT, FLANGE, 8X85	3
		23	95701-08016-00	BOLT, FLANGE, 8X16	4
		24	95701-08020-00	BOLT, FLANGE, 8X20	4



**F-26**  
TOOLS

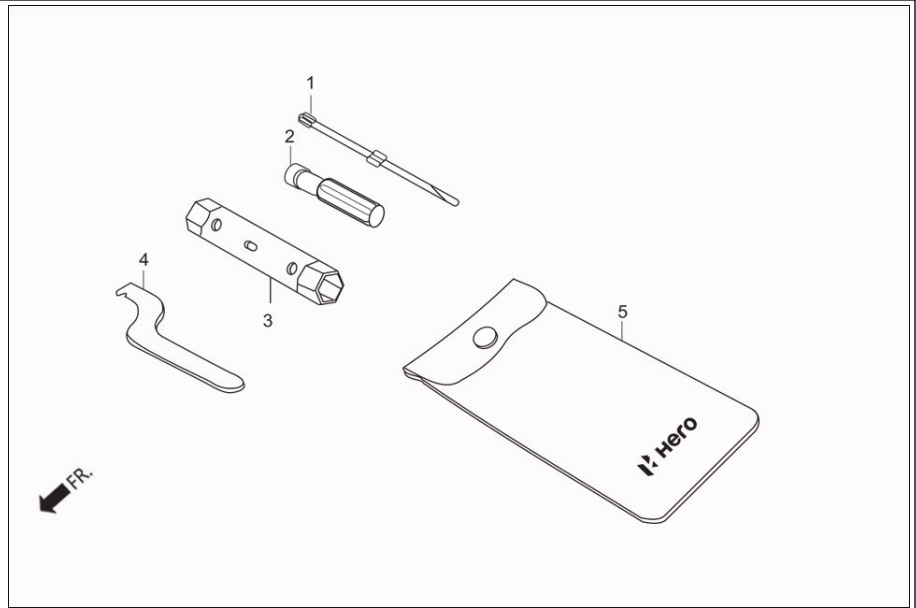

Service Item

F.R.T.

Group Number: F-26 Model :: ECO 150 (Dec, 2019)

Ref No.	Part Number	Description	Req.
1	89102-538-000	SCREW, DRIVER PLUS/MINUS	1
2	89103-538-000	GRIP, SCREW DRIVER	1
3	89215-AAC-000	BOX WRENCH P16X14	1
4	99007-45000	PIN, SPANNER	1
5	89216-AAD-H00	TOOL BAG	1

**F-27**  
STRIPE/ MARKS

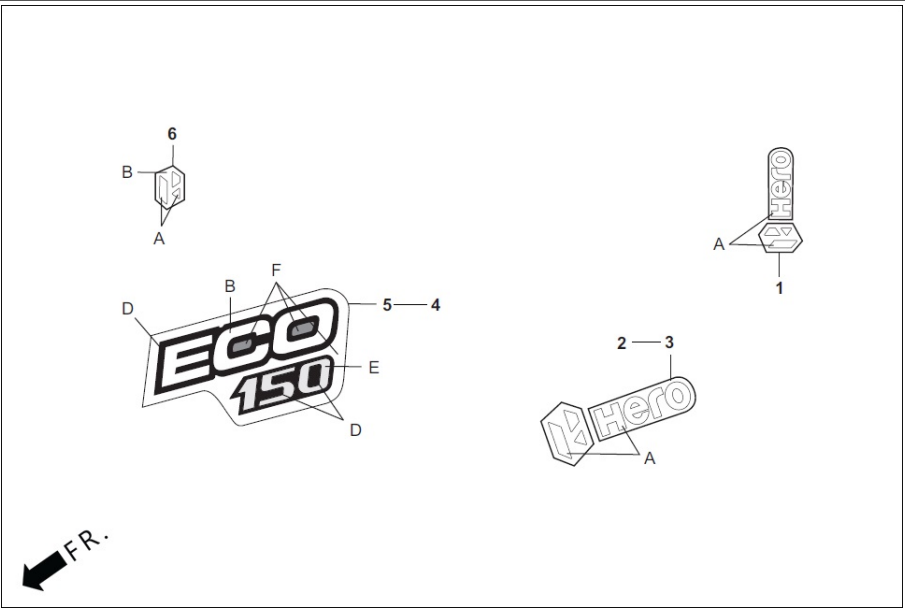

Service Item

F.R.T.

Group Number: F-27 Model :: ECO 150 (Dec, 2019)

Ref No.	Part Number	Description	Req.
1	77238-AAM-800R	MARK CENTER RR.COWL (TYPE-1)	1

**SPECIFIED COLOUR CHART FOR, MARK, CENTER REAR COWL**

SPECIFIED COLOUR TYPE	A	MAIN BODY COLOUR
1	WHITE 2	NH-1 BLACK CANDY BLAZING RED (R-195C) VIBRANT BLUE ME. (PB-374)

**F-27**  
STRIPE/ MARKS

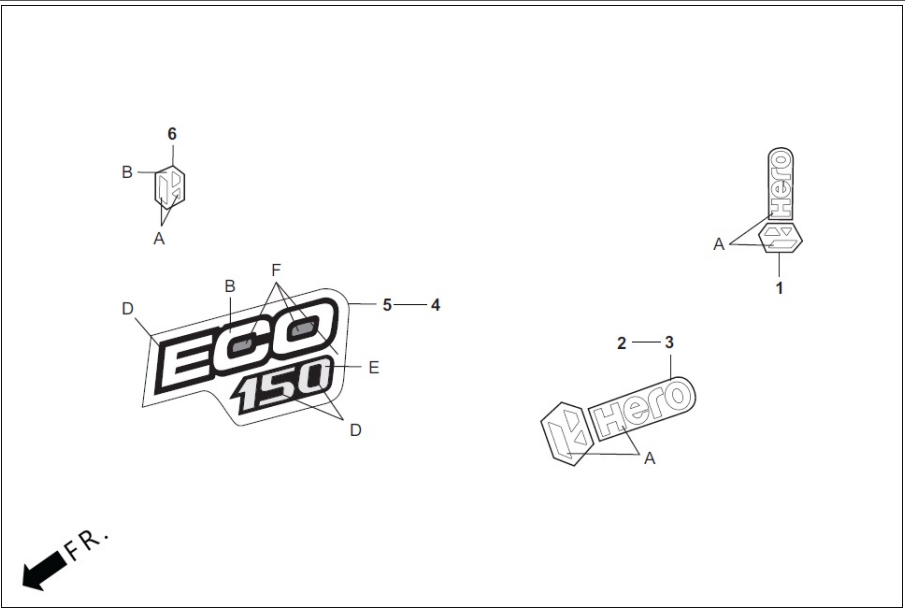

Service Item	F.R.T.	Group Number: F-27 Model :: ECO 150 (Dec, 2019)			
		Ref No.	Part Number	Description	Req.
		2	86117-AAM-800R	MARK HERO R SIDE COVER (TYPE-1)	1

**SPECIFIED COLOUR CHART FOR, MARK, HERO R. SIDE COVER**

SPECIFIED COLOUR TYPE	A	MAIN BODY COLOUR
1	WHITE 2	NH-1 BLACK CANDY BLAZING RED (R-195C) VIBRANT BLUE ME. (PB-374)

**F-27**  
STRIPE/ MARKS

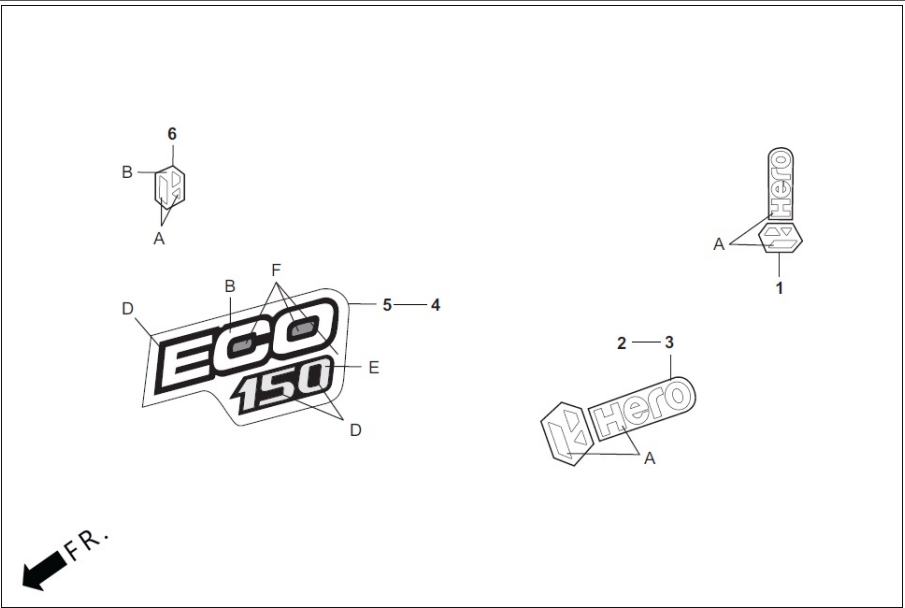

Service Item

F.R.T.

Group Number: F-27 Model :: ECO 150 (Dec, 2019)

Ref No.	Part Number	Description	Req.
3	86118-AAM-800R	MARK HERO L SIDE COVER (TYPE-1)	1

**SPECIFIED COLOUR CHART FOR, MARK, HERO L. SIDE COVER**

SPECIFIED COLOUR TYPE	A	MAIN BODY COLOUR
1	WHITE 2	NH-1 BLACK CANDY BLAZING RED (R-195C) VIBRANT BLUE ME. (PB-374)

**F-27**  
STRIPE/ MARKS

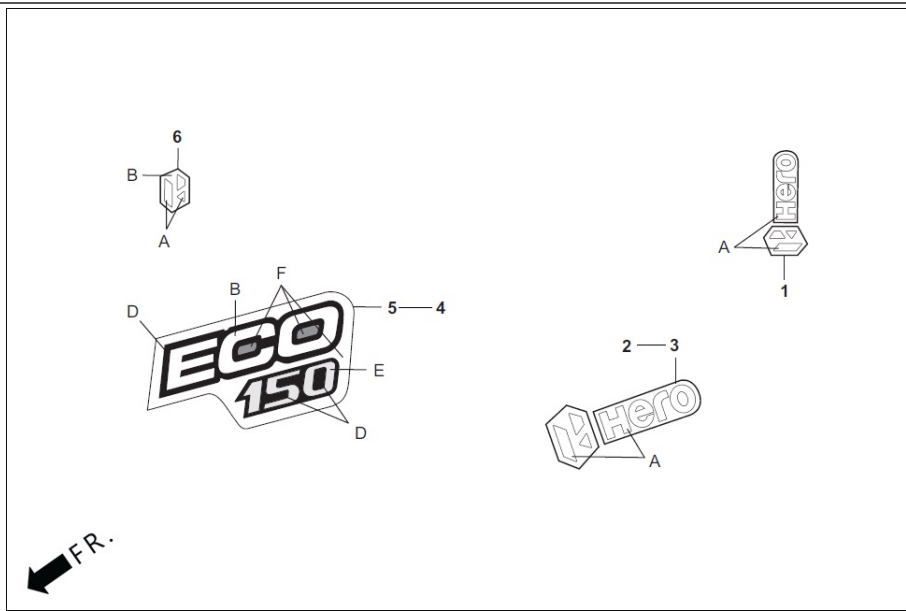

Service Item

F.R.T.

Group Number: F-27 Model :: ECO 150 (Dec, 2019)

Ref No.	Part Number	Description	Req.
4	86505-AAM-A00R	STRIPE R. FUEL TANK (TYPE-1)	1
	86505-AAM-A00S	STRIPE R. FUEL TANK (TYPE-2)	1



**SPECIFIED COLOUR CHART FOR, STRIPE, RIGHT FUEL TANK**

SPECIFIED COLOUR TYPE	<b>A</b>	<b>D</b>	<b>E</b>	<b>F</b>	<b>MAIN BODY COLOUR</b>
1	WHITE 2	HEAVY GREY	FORCE SILVER	NH-1 BLACK	NH-1 BLACK
2	WHITE 2	NH-1 BLACK	FORCE SILVER	TRANSPARENT	CANDY BLAZING RED (R-195C)
2	WHITE 2	NH-1 BLACK	FORCE SILVER	TRANSPARENT	VIBRANT BLUE ME. (PB-374)

**F-27**  
STRIPE/ MARKS

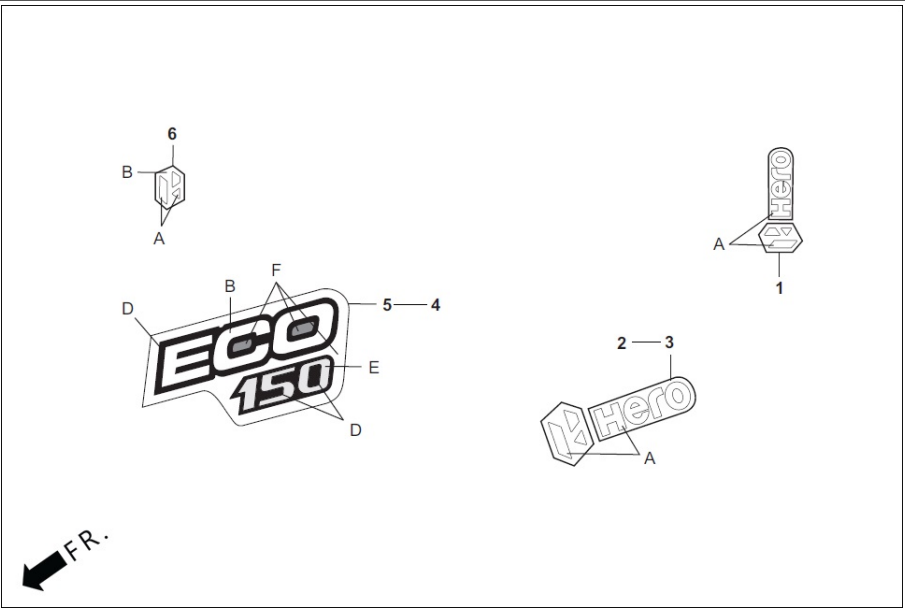

Service Item

F.R.T.

Group Number: F-27 Model :: ECO 150 (Dec, 2019)

Ref No.	Part Number	Description	Req.
5	86506-AAM-A00R	STRIPE L. FUEL TANK (TYPE-1)	1
	86506-AAM-A00S	STRIPE L. FUEL TANK (TYPE-2)	1

<b>SPECIFIED COLOUR CHART FOR, STRIPE, LEFT FUEL TANK</b>					
<b>SPECIFIED COLOUR TYPE</b>	<b>A</b>	<b>D</b>	<b>E</b>	<b>F</b>	<b>MAIN BODY COLOUR</b>
1	WHITE 2	HEAVY GREY	FORCE SILVER	NH-1 BLACK	NH-1 BLACK
2	WHITE 2	NH-1 BLACK	FORCE SILVER	TRANSPARENT	CANDY BLAZING RED (R-195C)
2	WHITE 2	NH-1 BLACK	FORCE SILVER	TRANSPARENT	VIBRANT BLUE ME. (PB-374)

**F-27**  
STRIPE/ MARKS

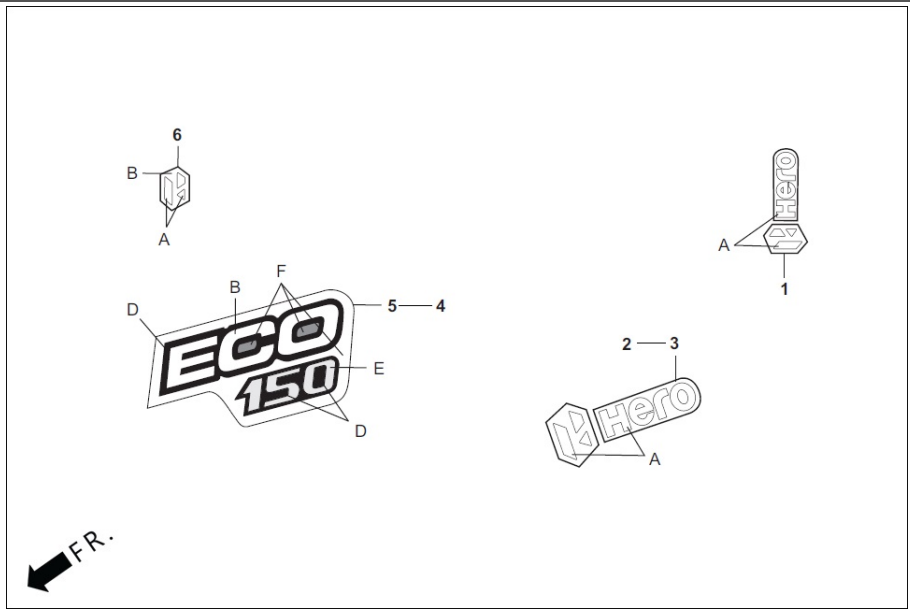

Service Item

F.R.T.

Group Number: F-27 Model :: ECO 150 (Dec, 2019)

Ref No.	Part Number	Description	Req.
6	77237-AAG-C00R	H MARK WIND SCREEN (TYPE-1)	1

**SPECIFIED COLOUR CHART FOR, 'H' MARK, WIND SCREEN**

SPECIFIED COLOUR TYPE	A	B	MAIN BODY COLOUR
1	ROSE WHITE	TRANSPARENT	NH-1 BLACK CANDY BLAZING RED (R-195C) VIBRANT BLUE ME. (PB-374)

**F-28**  
 GUARD, FRONT (OPTIONAL)

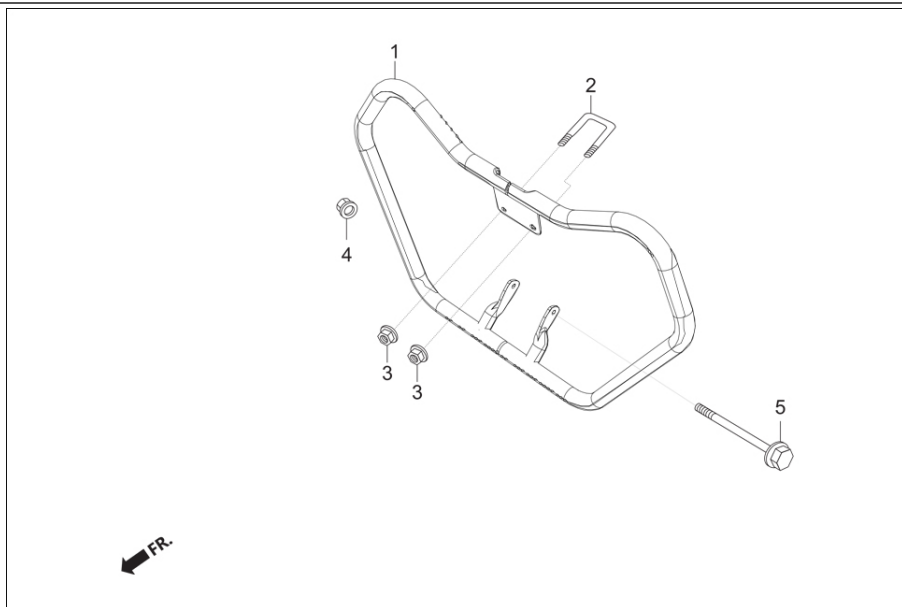

**Service Item**

**F.R.T.**

<b>Group Number: F-28 Model :: ECO 150 (Dec, 2019)</b>			
<b>Ref No.</b>	<b>Part Number</b>	<b>Description</b>	<b>Req.</b>
1	50803-KVE-900	GUARD, FRONT	1
2	50805-KVE-900	U-CLAMP	1
3	94050-08070	NUT, FLANGE, 8MM	2
4	94050-08000	NUT, FLANGE, 8MM	1
5	95801-08095-00	BOLT, FLANGE, 8 X 95	1

**F-28A**  
(OPTIONAL)

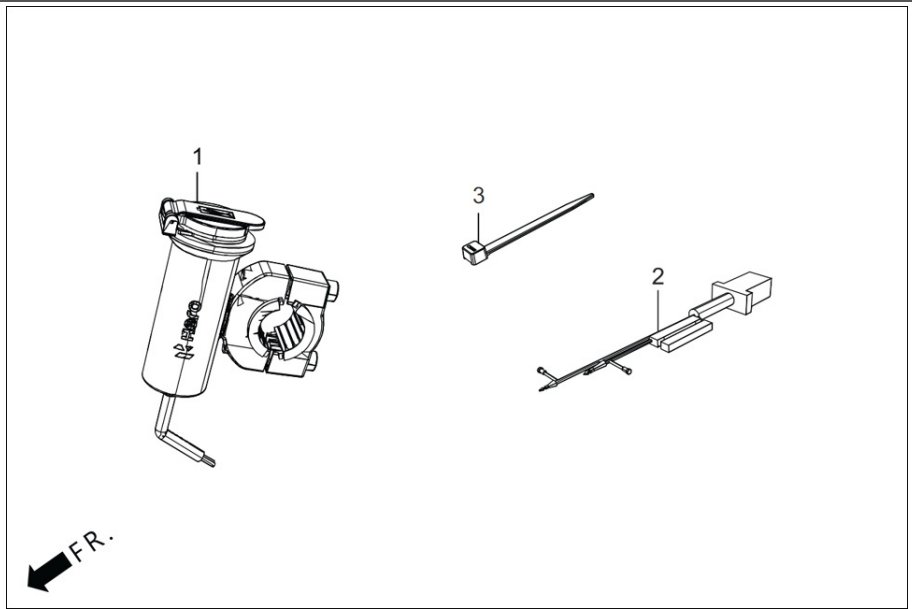

Service Item	F.R.T.	Group Number: F-28A Model :: ECO 150 (Dec, 2019)			
		Ref No.	Part Number	Description	Req.
		1	31304-AAE-400	USB CHARGER	1
			31302-AAM-600	USB CHARGER ASSY.	1
		2	31305-AAM-600	WIRE HARNESS FOR USB CHARGER	1
		3	91551-AAB-100	BAND, CLAMP	2

**F-29**  
PILLION STEP REAR DOUBLE

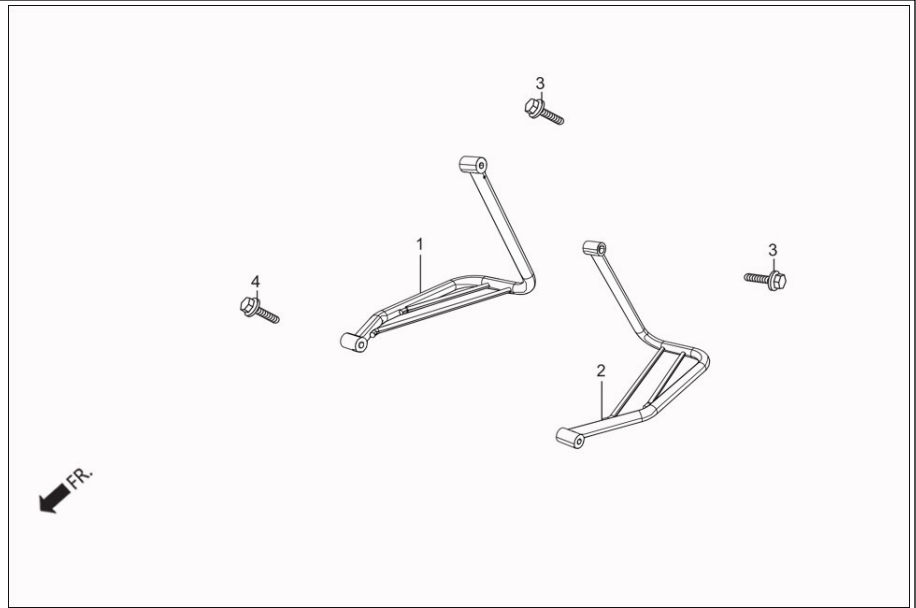

Service Item	F.R.T.
* GUARD, SARI	0.3

**Group Number:** F-29 **Model ::** ECO 150 (Dec, 2019)

Ref No.	Part Number	Description	Req.
1	51102-AAM-300	STEP COMP R P DOUBLE	1
2	51202-AAM-300	STEP COMP L P DOUBLE	1
3	96700-08048-00	SOCKET, BOLT, 8 X 48	2
4	95801-08060-00	BOLT, FLANGE, 8X60	1



## F-30 CAUTION LABEL

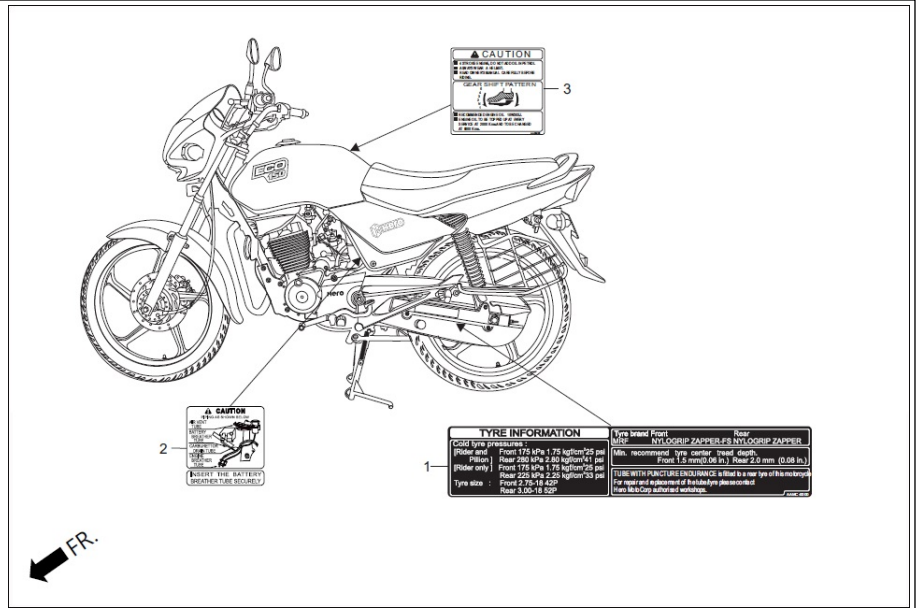

Service Item

F.R.T.

Group Number: F-30 Model :: ECO 150 (Dec, 2019)

Ref No.	Part Number	Description	Req.
1	87505-AAM-H10	LABEL, TYRE	1
2	87506-KRC-900	MARK, BATTERY CAUTION	1
3	87560-AAM-H00	LABEL DRIVE	1

# **PARTS INDEX**

<b>PART NO</b>	<b>BLOCK</b>	<b>PART NO</b>	<b>BLOCK</b>
3310B-AAJ-H03	F-1	14771-KSP-910	E-2
3340A-AAM-301	F-22	14777-KSP-910	E-2
3345A-AAM-301	F-22	14781-MA6-000	E-2
3360A-AAM-301	F-22	15100-KRM-840	E-8A
3365A-AAM-301	F-22	15130-KRM-840	E-8A
3370A-AAM-301	F-23	15331-KRM-840	E-8A
3710A-AAM-800	F-2	15332-KRM-840	E-8A
6130A-AAM-310	F-1	15421-KTN-900	E-8A
7720A-AAM-300	F-12	15430-KSP-910	E-8A
11100-AAM-300	E-8	15436-KRM-840	E-8A
11108-KTN-900	E-8	15441-KCS-650	E-8A
11200-AAM-300	E-8	15446-107-000	E-8A
11215-KSP-910	E-8	15459-KWK-900	E-8A
11216-KRM-840	E-8	15651-KTN-900	E-5
11217-KRM-840	E-8	15772-KTN-900	F-25
11330-AAM-300	E-5	16010-KSP-911	E-13
11341-AAM-300	E-7C	16012-AAM-001	E-13
11360-AAM-300	E-7C	16013-KRC-921	E-13
11365-KSP-910	E-7C	16015-KSP-911	E-13
11393-KWK-900	E-5	16016-KPP-901	E-13
11395-KWK-900	E-7C	16028-KPP-901	E-13
12100-AAM-300	E-3	16037-KPP-861	E-13
12191-KWK-900	E-3	16046-KTN-901	E-13
12200-AAM-300	E-1A	16050-KTN-901	E-13
12204-KRM-305	E-1A	16075-KRP-981	E-13
12205-KSP-305	E-1A	16080-KTN-901	E-13
12209-AAN-410	E-2	16100-AAM-401	E-13
12210-KSP-910	E-1A	16107-KGF-901	E-13
12212-KRM-840	E-1A	16111-KTN-901	E-13

12213-KSP-910	E-1A	16119-KSP-911	E-13
12251-KSP-910	E-1A	16140-KTN-901	E-13
12311-AAM-300	E-1	16150-KTN-700H	F-3
12391-KRM-840	E-1	16155-KFR-701	E-13
12396-KRM-840	E-1	16163-KRP-981	E-13
13000-KSP-911	E-9	16165-KSP-911	E-13
13011-KRM-305	E-9	16173-001-000	F-13
13021-KRM-305	E-9	16180-KGF-9010	E-13
13031-KRM-305	E-9	16199-KTN-700	F-15
13041-KRM-305	E-9	16210-AAM-100	E-1A
13051-KRM-305	E-9	16217-KSP-910	E-1A
13101-KSP-910	E-9	16222-KSP-910	E-1A
13102-KSP-305	E-9	16423-KGH-901	E-13
13103-KSP-305	E-9	16950-AAM-10099	F-13
13104-KSP-305	E-9	16952-KCC-900	F-13
13105-KSP-305	E-9	16958-397-770	F-13
13111-KSP-910	E-9	16967-MA2-770	F-13
13201-KRM-840	E-9	17211-KVN-900	F-15
13380-KRM-840	E-9	17213-KRY-900	F-15
13412-KSP-910	E-9	17214-KRY-900	F-15
14100-KTN-900	E-2	17215-KTN-700	F-15
14311-KRM-840	E-9	17216-KVN-900	F-15
14321-KRM-840	E-4	17219-KTN-700H	F-15
14401-KCW-851	E-4	17222-KTN-700	F-15
14430-KSP-910	E-2	17225-KTN-700H	F-15
14451-KRM-840	E-2	17232-KTN-900	F-24A
14510-KVE-900	E-4	17234-KS4-770	F-15
14515-KRM-840	E-4	17234-KRC-900	F-15
14520-AAB-A0099	E-4	17235-KTN-700	F-15
14560-KSP-910	E-4	17245-KTN-700H	F-15

14610-KSP-910	E-4	17311-KRC-910	F-15
14711-KSP-910	E-2	17312-KFN-880	F-15
14721-KSP-910	E-2	17369-AAM-100	F-15
14751-KTN-900	E-2	17371-KTN-700	F-15
14761-KTN-900	E-2	17500-AAM-A00R	F-13

<b>PART NO</b>	<b>BLOCK</b>	<b>PART NO</b>	<b>BLOCK</b>
17500-AAM-A00S	F-13	24627-KRM-840	E-12
17500-AAM-A00T	F-13	24651-KSP-910	E-12
17506-KTN-700	F-13	24652-KSP-910	E-12
17611-KFN-850	F-13	24701-KTN-700	F-18
17613-MV4-000	F-13	24781-KR3-770	F-18
17620-KST-H61	F-13	28110-KTN-900	E-7A
17681-KTN-700	F-13	28120-KTR-A00A	E-7A
17910-KTN-700	F-3	28131-KTN-900	E-7A
17950-KTN-700	F-3	28132-KN6-930	E-7A
18291-KRY-930	F-16	28133-KRM-850	E-7A
18293-KPK-900	F-16	28211-KRM-840	E-11
18300-AAM-400	F-16	28215-KRM-840	E-11
18312-AAM-300	F-16	28221-KTN-900	E-11
18313-AAM-300	F-16	28223-KRM-840	E-11
18345-MBT-610	F-16	28231-KRM-840	E-11
18421-438-000	F-16	28241-KTN-700	F-18
18442-KRC-900	F-16	28251-KTN-900	E-11
18651-AAM-100	F-15	28261-KRM-840	E-11
19052-KV0-000	F-12	28282-KRM-840	E-11
19052-KV0-000	F-14	28293-333-000	F-18
19052-KV0-000	F-21	28300-KTN-760	F-18
19052-KV0-000	F-23	28311-KC5-000	F-18
22100-KTN-900	E-6	28333-KK0-000	F-18
22115-KSP-910	E-6	30401-KTN-901	F-24
22120-KRM-840	E-6	30410-KTN-901	F-24
22201-KPM-850	E-6	30500-KTN-900	F-24
22201-MR8-000	E-6	30604-KFL-D21	F-24
22321-KPS-900	E-6	30605-KE2-940	F-24
22355-KRM-840	E-6	30700-KJ9-020	F-24

22361-KPK-900	E-6	31100-KTN-901	E-7A
22366-KSP-910	E-6	31110-KSP-902	E-7A
22401-KRM-840	E-6	31120-KSP-911	E-7A
22810-KVE-900	E-5	31200-KSP-901	E-7B
22815-428-000	E-5	31201-KPT-A01	E-7B
22821-KRM-840	E-5	31204-KG8-004	E-7B
22870-KTN-950	F-3	31205-KTC-921	E-7B
22871-KTN-700	F-3	31206-KPH-881	E-7B
23121-KTN-900	E-9	31207-MBE-008	E-7B
23210-KVN-900	E-10	31302-AAM-600	F-28A
23220-KTN-900	E-10	31304-AAE-400	F-28A
23421-KVN-900	E-10	31305-AAM-600	F-28A
23427-KRM-840	E-10	31500-KCT-691	F-24A
23431-KVN-900	E-10	31502-KRC-760	F-24A
23432-KRM-840	E-10	31600-AAM-801	F-24
23441-KVN-900	E-10	31700-124-000	F-24
23451-KVN-900	E-10	31916-KRM-84099	E-1A
23461-KVN-900	E-10	32100-AAM-A00	F-24
23471-KVN-900	E-10	32108-197-000	F-24
23472-KSP-910	E-10	32111-KSP-910	E-7A
23481-KVN-900	E-10	32161-404-000	F-3
23491-KVN-900	E-10	32401-KTN-900	F-24
23492-KSP-910	E-10	32406-KAZ-000	F-24
23501-KVN-900	E-10	32410-KTN-900	F-24
23801-KSP-910	E-10	32411-253-000	F-24
23811-KR3-600	E-10	32414-KRC-900	F-24
24211-KRM-840	E-12	32601-KTN-900	F-24
24212-KRM-840	E-12	32602-KTN-900	F-24
24241-KRM-840	E-12	33101-KTN-921	F-1
24242-KRM-840	E-12	33108-KRY-900	F-1

24301-KSP-910	E-12	33108-KGA-900	F-1
24410-KSP-910	E-12	33112-KTN-921	F-1
24430-KTN-900	E-12	33120-AAJ-H03	F-1
24436-KSP-910	E-12	33150-KCC-830	F-1
24610-KSP-910	E-12	33401-KTR-901	F-22



<b>PART NO</b>	<b>BLOCK</b>	<b>PART NO</b>	<b>BLOCK</b>
33403-AAM-101	F-22	40520-KTN-760	F-19
33406-KTR-901	F-22	40530-KTN-700	F-19
33415-AAM-301	F-22	40531-KCS-690	F-19
33451-KTR-901	F-22	40543-KTN-700	F-19
33453-AAM-101	F-22	40544-KTN-700	F-19
33465-AAM-301	F-22	40545-001-000	F-19
33491-KAF-000	F-22	40546-KTN-700	F-19
33491-KRC-900	F-22	41201-KSP-900	F-11
33603-AAM-101	F-22	41241-KSP-900	F-11
33603-053-650	F-23	42301-KTN-700	F-11
33615-AAM-301	F-22	42303-KRY-900	F-11
33619-459-840A	F-16	42311-KRY-930	F-11
33650-KAF-000	F-22	42313-KTN-700	F-10
33653-AAM-101	F-22	42601-AAM-H50	F-11
33665-AAM-301	F-22	42611-KRY-930	F-11
33703-AAM-301	F-23	42620-KSP-900	F-11
33704-AAM-101	F-23	42711-KCC-730	F-11
33714-KL3-620	F-25	42712-KCS-920	F-9
33740-AAB-000	F-6	42712-P11-000	F-11
33741-AAM-101	F-21	43100-KRY-930	F-10
34901-KSP-910	F-1	43145-149-000	F-10
34904-AAM-301	F-22	43410-KTN-700	F-10
34906-AAN-601	F-23	43431-KTN-700	F-19
34908-KM1-671	F-2	43434-ME1-670	F-10
34908-MB9-800	F-2	43451-KTN-700	F-18
34908-MG9-951	F-2	44301-KSP-900	F-9
34920-AAK-201	F-1	44311-KRC-900	F-9
35010-AAM-101	F-4	44601-AAC-H00	F-9
35100-AAM-101	F-4	44620-400-000	F-9

35121-AAM-H00	F-4	44711-KFN-850R	F-9
35122-AAM-H00	F-4	44805-KTC-900	F-8
35150-AAM-411	F-3	44806-KST-900	F-8
35200-AAM-301	F-3	44809-170-000	F-8
35305-KE5-001	F-2	44810-KTC-900	F-8
35305-KE5-002	F-2	44830-KTN-950	F-2A
35330-413-003	F-3	44831-KTN-950	F-2A
35340-KCC-900	F-3	45010-AAM-000	F-8
35350-KFN-850	F-18	45125-AAH-F0099	F-8
35357-KTN-700	F-18	45125-AAH-F0099	F-8
35751-KPH-900	E-12	45125-AAH-F0099	F-10
35752-KRM-840	E-12	45125-AAH-F0099	F-10
35759-KTN-900	E-8	45133-KCC-900	F-8
35850-KR3-870	F-24	45133-KCC-900	F-10
35850-AAM-H01	F-24	45134-250-000	F-8
35856-MBG-003	F-24	45134-250-000	F-10
37110-AAM-301	F-2	45141-KTC-900	F-8
37120-AAM-301	F-2	45141-KTC-900	F-10
37121-ML7-671	F-2	45145-096-650	F-8
37200-AAM-H61	F-2	45410-AAM-000	F-8
37213-KY6-008	F-2	45435-GB2-720	F-8
37215-ML0-008	F-1VBA-W/O VISOR	45450-AAM-000	F-3
37215-ML0-008	F-2	45451-473-000	F-6
37223-KTN-901	F-2	45517-166-000	F-3
37250-AAM-H01	F-2	46500-KTN-700	F-18
37305-KE5-000	F-2	46514-KCC-900	F-18
37305-MAW-621	F-2	46515-KB9-000	F-18
37618-AAM-301	F-2	50100-AAM-400	F-25
37800-KFN-900	F-13	50169-KTN-700	F-25
37890-KTN-901	E-13	50172-KTN-700	F-25

38110-AAB-401	F-25	50173-KTN-700	F-25
38117-KFE-701	F-25	50186-KTN-700	F-21
38301-KK4-010	F-24	50301-KTR-900	F-5
38306-GE7-000	F-24	50351-KVE-900	F-25
40510-KTN-760	F-19	50383-KRC-900	F-24A

<b>PART NO</b>	<b>BLOCK</b>	<b>PART NO</b>	<b>BLOCK</b>
50500-KVE-930	F-18A	53216-KTN-700	F-5
50505-KTN-700	F-25	53221-KSP-900	F-5
50526-KCT-690	F-18A	53222-KRM-860	F-5
50530-KTN-700	F-18A	53230-KTN-700	F-4
50603-KR0-010	F-17	61100-AAM-500U	F-6
50603-KFN-850	F-17	61100-KTN-700ZCH	F-6
50610-KTN-700	F-17	61100-KTN-700ZE	F-6
50618-KE8-000	F-17	61102-KTN-700	F-6
50619-AAM-100	F-17	61103-KRY-900	F-6
50620-AAM-100	F-17	61105-KTC-900	F-6
50661-AAM-100	F-17	61301-AAM-300R	F-1VB-VISOR
50701-AAM-3000-20	F-17	61301-AAM-300S	F-1VB-VISOR
50701-KFN-850	F-17	61301-AAM-300U	F-1VB-VISOR
50702-AAM-3000-20	F-17	61302-471-000	F-1
50715-KFN-850	F-17	61303-198-D00	F-1
50801-KFN-850	F-17	61306-KTN-700	F-2
50803-KVE-900	F-28	61311-AAM-310	F-1VBA-W/O VISOR
50805-KVE-900	F-28	61312-KCT-690	F-1VBA-W/O VISOR
51102-AAM-300	F-29	61313-AAM-310	F-1VB-VISOR
51202-AAM-300	F-29	61313-AAM-300	F-1VBA-W/O VISOR
51400-AAM-000	F-7	61314-AAM-310	F-1VB-VISOR
51401-KSP-901	F-7	61314-AAM-300	F-1VBA-W/O VISOR
51410-KSP-901	F-7	64100-AAG-C00R	F-1VB-VISOR
51412-KFN-851	F-7	77110-KWA-H11	F-12A
51412-KSP-901	F-7	77151-MB1-870	F-12A
51420-AAM-000	F-7	77156-KCT-690	F-12A
51432-KFN-851	F-7	77160-ML7-700	F-12A
51435-AAM-400	F-6	77200-AAM-400	F-12
51436-AAM-400	F-6	77204-KTN-700	F-12

51437-KFN-851	F-7	77205-KTN-700	F-12
51440-KSP-901	F-7	77206-KTR-900	F-12
51488-KTN-701	F-20	77207-AAM-400	F-12
51500-AAM-000	F-7	77209-KAG-900	F-23
51520-AAM-000	F-7	77215-KRC-900H	F-12A
52101-KTN-700	F-19	77225-KRC-900H	F-12A
52110-AAM-000	F-19	77235-KRC-900	F-23
52141-KTN-700	F-19	77237-AAG-C00R	F-27
52144-KEJ-900	F-19	77238-AAM-800R	F-27
52170-KTN-700	F-19	77246-AAM-300	F-12A
52400-AAM-300	F-20	77256-AAM-300	F-12A
52410-KTN-701	F-20	77280-AAM-800R	F-12A
52486-KTN-701	F-20	80100-KTN-700	F-21
52489-399-600	F-20	80101-KFN-850	F-13
53100-AAM-800	F-4	80102-AAM-300	F-21
53105-KRC-900	F-4	80130-KRC-900	F-21
53132-124-000	F-4	81200-AAM-400	F-25
53133-198-900	F-4	83100-KTN-720ZCH	F-12
53134-028-000	F-4	83100-KTN-720ZEH	F-12
53135-198-900	F-4	83100-KTN-H00ZF	F-12
53136-198-900	F-4	83200-KTN-720ZCH	F-12
53140-KFN-850	F-3	83200-KTN-720ZEH	F-12
53166-KFN-850	F-3	83200-KTN-H00ZF	F-12
53171-AAM-300	F-3	83402-AAM-300	F-1VB-VISOR
53172-KRC-900	F-3	83500-AAM-B00R	F-14
53175-AAM-300	F-3	83541-KTN-700	F-14
53178-KFN-850	F-3	83545-KCJ-690	F-12
53181-KFN-870	F-3	83545-KCJ-690	F-14
53182-KFN-850	F-3	83545-KCJ-690	F-21
53200-KTN-700	F-5	83545-KCJ-690	F-23

53208-AAH-000	F-4	83551-300-000	F-13
53211-268-010	F-5	83551-GE2-000	F-21
53212-200-000	F-5	83551-300-000	F-25
53214-200-000	F-5	83600-AAM-B00R	F-14
53215-KTR-900	F-5	83641-KTN-700	F-14

<b>PART NO</b>	<b>BLOCK</b>	<b>PART NO</b>	<b>BLOCK</b>
84103-KCC-900	F-25	90231-KM7-700	E-8A
84701-KCC-860	F-21	90301-473-000	F-10
84701-P26-D00A	F-21	90302-KTE-911	F-6
86117-AAM-800R	F-27	90304-GA6-000	F-4
86118-AAM-800R	F-27	90304-AAH-000	F-4
86505-AAM-A00R	F-27	90304-KCS-920	F-11
86505-AAM-A00S	F-27	90304-KFN-850	F-18A
86506-AAM-A00R	F-27	90305-KVN-900	F-11
86506-AAM-A00S	F-27	90305-KSP-900	F-16
87505-AAM-H10	F-30	90305-KVN-900	F-19
87506-KRC-900	F-30	90306-KRM-840	E-1A
87560-AAM-H00	F-30	90306-KST-942	F-9
88110-AAM-100	F-3	90306-KTE-911	F-9
88114-KFN-950	F-3	90320-GC3-000	F-1VB-VISOR
88120-AAM-100	F-3	90320-GC3-000	F-12A
89102-538-000	F-26	90320-GC3-000	F-21
89103-538-000	F-26	90344-KEV-900	F-23
89215-AAC-000	F-26	90380-MB2-000	F-22
89216-AAD-H00	F-26	90401-KRM-840	E-6
90001-KRC-900	F-17	90404-KPT-A00	E-1A
90002-KRM-840	E-1A	90417-KRM-840	E-12
90003-KFG-000	E-1	90417-KRM-840	F-25
90003-KVS-900	E-12	90432-KPT-A00	E-8A
90003-MY5-720	F-3	90441-KRM-840	E-8
90005-KY7-000	E-4	90451-KRM-840	E-11
90006-MEE-000	E-1A	90452-KRM-840	E-10
90008-KRM-840	E-6	90452-GB4-770	E-10
90012-KK3-830	E-2	90453-KRM-840	E-10
90019-399-010	F-25	90454-107-000	E-10

90022-MG8-000	E-12	90455-KSP-910	E-11
90031-KSP-910	E-8	90456-KRM-840	E-10
90032-KW3-000	F-2	90457-KRM-840	E-12
90040-KSP-910	E-1A	90463-KRM-840	E-1
90071-MB0-000	E-7B	90501-KPT-A00	E-6
90083-KRM-840	E-4	90501-KPT-A00	E-7A
90084-KWA-930	E-7C	90502-198-900	F-18
90084-041-000	E-10	90503-KTR-900	F-4
90085-KTC-920	E-7A	90505-425-000	F-10
90087-AAM-300	E-7C	90505-KRM-860	F-18
90101-GE0-000	F-1VB-VISOR	90521-292-000	F-7
90101-KY6-000	F-2	90521-028-000	F-18
90101-GE0-000	F-12A	90525-030-000	F-2
90101-087-720	F-12A	90534-MV4-000	F-13
90102-GB2-720	F-12A	90543-MV9-670	E-1
90105-KVN-900	F-14	90544-KFN-851	F-7
90107-GZ4-670	F-12A	90551-178-000	F-20
90107-GN1-010	F-18A	90559-KTN-700	F-11
90111-187-000	F-15	90560-KTN-700	F-11
90111-MR5-000	F-24	90563-355-000	F-23
90113-438-000	F-3	90601-AAB-A00	E-10
90116-KAG-900	F-7	90601-KFN-851	F-7
90117-KY0-860	F-4	90601-KAF-003	F-18
90123-KRM-860	F-7	90602-KRM-840	E-11
90123-KSP-901	F-7	90605-200-000	E-10
90125-AAM-000	F-17	90651-MK3-780	F-15
90131-KRM-840	E-8	90651-MK3-780	F-25
90133-SL9-003	F-2	90701-KFN-850	E-5
90133-331-770	F-19	90704-KRM-840	E-1A
90140-KAE-000	F-3	90741-KFB-000	E-9



90158-KM7-911	F-2	90741-KGH-900	E-9
90201-KRM-840	E-7A	90810-KCC-910	F-1VB-VISOR
90201-MW3-620	F-3	91001-KTN-900	E-9
90202-KRM-840	E-6	91002-KSP-911	E-9
90206-250-000	E-2	91003-KSP-910	E-10

<b>PART NO</b>	<b>BLOCK</b>	<b>PART NO</b>	<b>BLOCK</b>
91004-KTN-900	E-10	94001-06000-0S	F-21
91005-KTN-900	E-10	94002-06000-0S	F-3
91006-KTN-900	E-10	94002-10070-0S	F-3
91007-KTN-900	E-2	94002-08000-0S	F-3
91008-KTN-900	E-2	94002-10000-0S	F-20
91022-KTN-900	E-7A	94021-06090-0S	F-24A
91101-KTN-901	E-9	94030-08000	F-3
91102-KTN-901	E-9	94050-06000	F-3
91103-KTN-901	E-9	94050-06000	F-8
91202-KSP-911	E-5	94050-06000	F-13
91203-KSP-910	E-8	94050-10000	F-16
91204-MC7-003	E-5	94050-10000	F-20
91216-KSP-910	E-10	94050-06000	F-21
91251-GK4-000	F-8	94050-10000	F-22
91251-KPH-901	F-9	94050-06000	F-23
91253-KSP-901	F-11	94050-08000	F-25
91254-GAA-003R	F-7	94050-10000	F-25
91255-GAA-003R	F-7	94050-08070	F-28
91303-KRM-840	E-7C	94050-08000	F-28
91304-KRM-840	E-1A	94101-04700	F-3
91305-KRM-840	E-7C	94101-08700	F-5
91305-KPH-900	E-8	94101-05000	F-15
91305-443-740	F-13	94101-06000	F-16
91306-MG3-000	E-4	94101-08000	F-19
91307-KRM-840	E-5	94101-12800	F-20
91309-425-003	E-7B	94101-06000	F-21
91320-MB0-000	E-7B	94102-08000	F-17
91352-GAZ-930	F-2A	94103-10000	F-16
91352-KSP-900	F-11	94109-12000	E-8

91356-KAG-900	F-7	94111-10000	F-19
91406-KFN-850	F-15	94201-20150	F-10
91463-393-780	F-15	94201-20150	F-17
91508-KST-940	F-1	94201-20150	F-18
91547-SF4-003	F-24	94201-30300	F-18
91551-AAB-100	F-28A	94201-30300	F-18A
92000-06012-0A	F-21	94201-20150	F-19
92101-06012-0G	F-17	94251-08000	E-8A
92811-10000	F-10	94301-08140	E-1
92915-10025-0E	F-11	94301-10120	E-1A
93500-04008-1A	E-13	94301-10120	E-3
93500-04012-0H	E-13	94301-08140	E-5
93500-05012-0A	E-13	94301-08140	E-7C
93500-04032-0G	F-15	94301-08140	E-8
93500-04025-0G	F-15	94301-08140	E-8A
93500-05016-1H	F-15	94510-16000	E-11
93500-05020-0A	F-24	94510-14000	E-12
93700-05012-0A	E-8A	94601-14000	E-9
93892-AAR-001	E-13	95002-02089	E-13
93892-05020-07	F-3	95002-50000	F-13
93892-05025-07	F-3	95002-02080	F-13
93892-05035-07	F-3	95002-70000	F-15
93892-05045-07	F-3	95002-80000	F-15
93901-34120	E-8A	95005-45480-50	E-13
93901-04012-00	F-1	95014-21101	F-4
93901-22310	F-22	95014-73100	F-18
93901-34680	F-23	95014-71702	F-18A
93903-34380	F-1VB-VISOR	95014-72102	F-18A
93903-25210	F-12A	95015-42000	F-8
93903-25220	F-21	95015-32001	F-8

93903-34480	F-22	95015-32001	F-18
94001-08000-0S	F-10	95015-42000	F-18
94001-10000-0S	F-19	95015-53000	F-18
94001-08000-0S	F-19	95018-52320	F-15
94001-06000-0S	F-19	95020-15100	F-11

<b>PART NO</b>	<b>BLOCK</b>	<b>PART NO</b>	<b>BLOCK</b>
95701-06014-00	E-1A	96700-08020-00	F-4
95701-06016-00	E-1A	96700-08048-00	F-29
95701-06022-00	E-1A	98200-31500	F-24
95701-06016-00	E-4	98200-32000	F-24
95701-06022-00	E-7B	99007-45000	F-26
95701-06016-00	E-8	99101-AAM-1100	E-13
95701-06020-00	E-8		
95701-06040-00	E-8		
95701-06045-00	E-8		
95701-06070-00	E-8		
95701-06035-00	E-8A		
95701-06016-00	E-11		
95701-08020-02	F-1		
95701-08035-07	F-5		
95701-06032-00	F-8		
95701-06035-00	F-10		
95701-06020-00	F-12		
95701-08025-00	F-13		
95701-10025-00	F-17		
95701-08020-00	F-17		
95701-06020-00	F-18		
95701-06012-00	F-19		
95701-06012-00	F-21		
95701-06020-00	F-21		
95701-06022-00	F-23		
95701-06016-00	F-24		
95701-06016-00	F-24A		
95701-06008-00	F-24A		
95701-06012-00	F-25		

95701-06014-00	F-25
95701-06020-07	F-25
95701-08016-00	F-25
95701-08020-00	F-25
95801-06105-00	E-1A
95801-10055-00	F-16
95801-08035-00	F-18
95801-10035-00	F-20
95801-08085-00	F-25
95801-08095-00	F-28
95801-08060-00	F-29
96001-06012-00	E-1
96001-06022-00	E-4
96001-06030-00	E-5
96001-06040-00	E-5
96001-06030-00	E-7C
96001-06035-00	E-7C
96001-06045-00	E-7C
96001-06018-00	E-8
96001-06012-02	F-1VB-VISOR
96001-06012-02	F-1VBA-W/O VISOR
96001-06022-07	F-3
96001-06012-07	F-5
96001-06020-07	F-5
96001-06035-00	F-6
96001-06012-07	F-16
96100-60030-00	E-6
96140-63010-10	F-9
96140-63020-10	F-11
96150-60050-10	F-11

96211-08000

F-5

96211-08000

F-18

96220-30085

E-12

96600-06016-00

E-7A

96600-06025-00

E-7A

## BLOCK INDEX - GROUP Engine - ECO 150 (Dec, 2019).

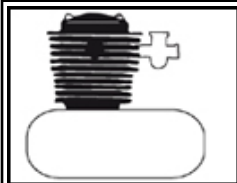

E-1	CYLINDER HEAD COVER	1
E-1A	CYLINDER HEAD	2
E-2	CAM SHAFT / VALVE	3
E-3	CYLINDER	4

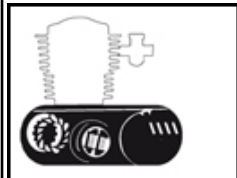



















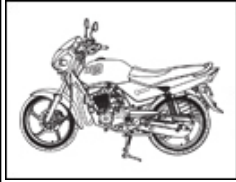









E-4	CAM CHAIN TENSIONER	5
E-5	RIGHT CRANK CASE COVER	6
E-6	CLUTCH	7
E-7A	A. C. GEN. ASSY.	8
E-7B	STARTER MOTOR	9
E-7C	LEFT CRANK CASE COVER	10
E-8	CRANK CASE	11
E-8A	OIL PUMP	12



E-9	CRANK SHAFT / PISTON	13
E-10	TRANSMISSION	15
E-11	SPINDLE KICK STARTER	16
E-12	DRUM GEAR SHIFT	17
E-13	CARBURETTOR	18



## BLOCK INDEX - GROUP Frame - ECO 150 (Dec, 2019).

	 F-1	HEAD LIGHT	19
	 F-1VB-VISOR	COWL FRONT (VISOR)	20
	 F-1VBA-W/O VISOR	COWL FRONT (W/O VISOR)	21
	 F-2	SPEEDOMETER	22
	 F-2A	SPEEDOMETER. CABLE	23
	 F-3	HANDLE LEVER / SWITCH / CABLES	24
	 F-4	HANDLE PIPE / TOP BRIDGE	25
	 F-5	STRG. STEM	26
	 F-6	FRONT FENDER	27
	 F-7	FRONT FORK	28
	 F-8	FRONT BRAKE	29
	 F-9	FRONT WHEEL	30
	 F-10	REAR BRAKE PANEL	31
	 F-11	REAR WHEEL	32
	 F-12	SEAT ASSY./COVER FRONT	33
	 F-12A	REAR COWL	34
	 F-13	FUEL TANK	35
	 F-14	SIDE COVER	36
	 F-15	AIR CLEANER	37
	 F-16	MUFFLER EXHAUST	38
	 F-17	STEP PILLION	39
	 F-18	PEDAL GEAR CHANGE / KICK STARTER / PEDAL BRAKE	40
	 F-18A	MAIN STAND / SIDE STAND	41
	 F-19	SWINGARM / CHAIN CASE	42
 F-20	CUSHION REAR	43	

## BLOCK INDEX - GROUP Frame - ECO 150 (Dec, 2019).



F-21

REAR FENDER

44

F-22

WINKER

45

F-23

TAIL LIGHT

46



F-24

WIRE HARNESS/START CABLES

47

F-24A

BATTERY ASSY

48

F-25

FRAME BODY / GRIP REAR

49

F-26

TOOLS

50

F-27

STRIPE/ MARKS

51

F-28

GUARD, FRONT (OPTIONAL)

57

F-28A

(OPTIONAL)

58

F-29

PILLION STEP REAR DOUBLE

59

F-30

CAUTION LABEL

60