

# **PARTS CATALOGUE**

**Karizma ZMR (May, 2014)**

**E-1**  
CYLINDER HEAD COVER

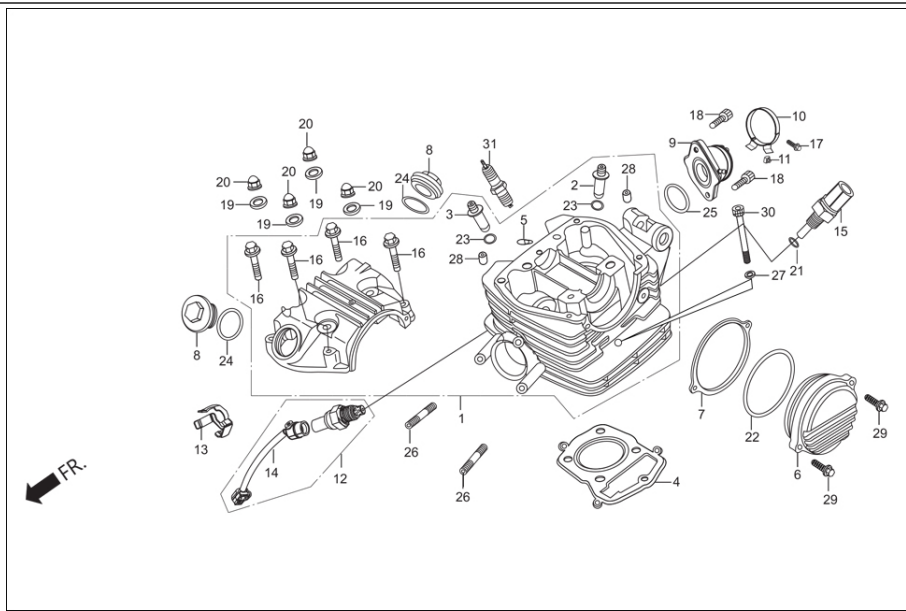

<b>Service Item</b>		<b>F.R.T.</b>	<b>Group Number: E-1 Model :: Karizma ZMR (May, 2014)</b>			
			<b>Ref No.</b>	<b>Part Number</b>	<b>Description</b>	<b>Req.</b>
HEAD ASSY., CYLINDER		*4.0	1	12000-AAR-000	HEAD ASSY CYLINDER	1
GUIDE VALVE		*3.8	2	12204-439-305	GUIDE, INLET VALVE(OVER SIZE)	1
(INC. REAMING)		--	3	12206-KCN-305	GUIDE, EXHAUST VALVE(OVER SIZE)	1
(ADD 0.3 FOR EACH)		--	4	12251-KT0-711	GASKET, CYLINDER HEAD	1
(ADD 0.7 FOR EACH)		--	5	12271-383-000	RUBBER, OIL SEAL	1
( ADD MORE 0.2 IF PERFORMED)		--	6	12331-KRY-960	COVER LEFT CYLINDER HEAD	1
GASKET, CYLINDER HEAD		*2.8	7	12339-KT0-711	GASKET, PLUSE GEN BASE	1
COVER 'L' CYLINDER HEAD		0.2	8	12361-KEZ-900	HOLE CAP, TAPPET ADJUSTING	2
INSULATOR, CARBURETTOR		0.3	9	16210-KRY-971	INSULATOR COMP.THROTTLE BODY	1
BOLT, STUD. 11.7X35		--	10	16221-KRY-970	BAND	1
(ADD 0.1 FOR EACH )		--	11	16222-KSP-910	NUT, SQUARE, 5 MM	1
SPARK PLUG		0.1	12	36532-KRY-971	SENSOR OXYGEN	1
			13	36538-KWF-940	COVER O2 SENSOR	1
			14	36533-KRY-970	CORD COMP. OXYGEN SENSOR	1
			15	37750-AAR-001	SENSOR ASSY T OIL	1
			16	90004-GHB-700	BOLT, FLANGE, NSHF, 6X35	4
			17	90006-MEE-000	BOLT RECESSED 5 X 30	1
			18	90091-MM5-640	BOLT, FLANGE, SOCKET, 6 X 22	2
			19	90442-028-000	WASHER, SEALING, 8 MM	4
			20	90443-107-000	NUT, CAP, 8 MM	4
			21	90443-MB0-000	WASHER SEALING, 10MM	1
			22	91301-107-000	O-RING, 75X2.5	1
			23	91301-200-000	O-RING, 10 X 1.6	2
			24	91303-KCS-920	O-RING, 35X3	2
			25	91304-KRM-840	O-RING 33.5 X 3.0	1
			26	92900-08025-0E	BOLT STUD 2,8X25	2
			27	94101-06000	WASHER, PLAIN, 6 MM	1
			28	94301-08140	DOWEL PIN, 8X14	2

29	96001-06025-00	BOLT, FLANGE, SH. 6 X 25	2
30	96700-06125-00	SOCKET, BOLT, 6 X 125	1
31	31918-HM5-630	SPARK PLUG	1

## E-2 CYLINDER

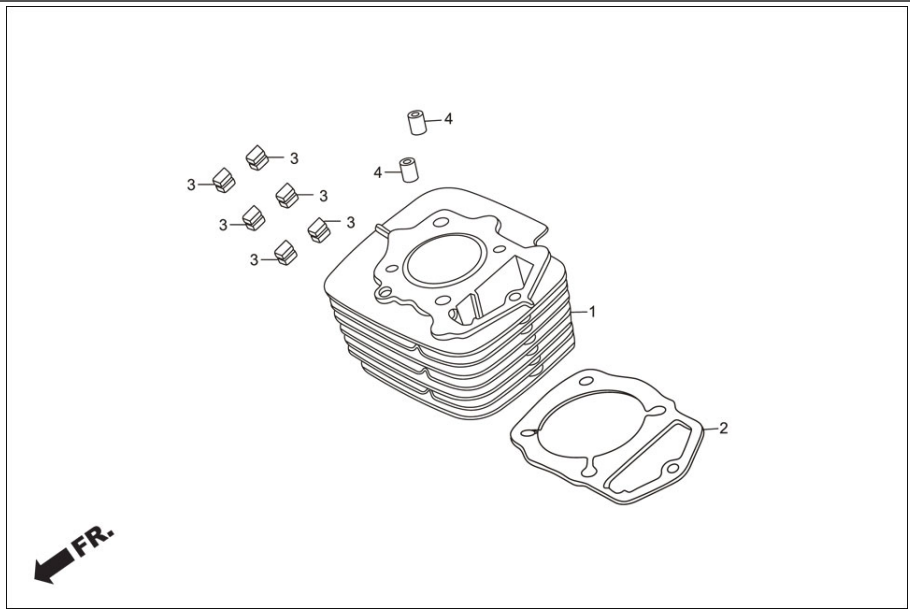

Service Item	F.R.T.
CYLINDER COMP.	*3.1
GASKET, CYLINDER	*3.0

Group Number: E-2 Model :: Karizma ZMR (May, 2014)				
Ref No.	Part Number	Description	Req.	
1	12100-KRY-960	CYLINDER COMP.,	1	
2	12191-KCN-010	GASKET, CYLINDER	1	
3	12195-KRC-920	RUBBER, INSERT	6	
4	94301-10200	DOWEL PIN, 10X20	2	

**E-3**  
CAM SHAFT / VALVE

FR. ←

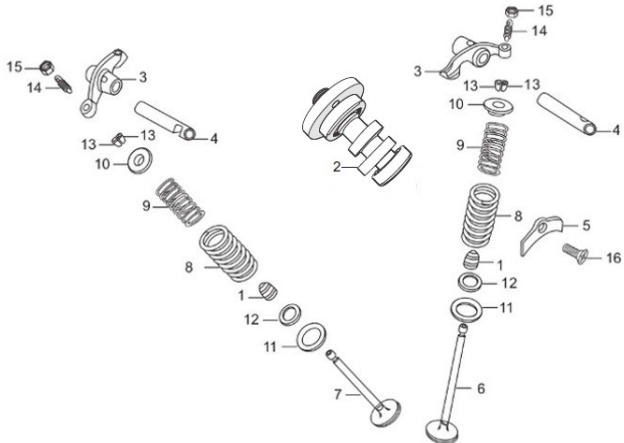

<b>Service Item</b>	<b>F.R.T.</b>	<b>Group Number: E-3 Model :: Karizma ZMR (May, 2014)</b>			
		<b>Ref No.</b>	<b>Part Number</b>	<b>Description</b>	<b>Req.</b>
CAM SHAFT COMP.	*2.8	1	12208-KCS-920	SEAL, VALVE STEM	2
ARM, VALVE ROCKER	*2.4	2	14100-AAR-000	CAM SHAFT COMP.	1
(ADD 0.1 FOR EACH )	--	3	14431-KEH-900R	ARM, VALVE ROCKER	2
VALVE	*3.6	4	14451-437-000	SHAFT, ROCKER ARM	2
(ADD 0.2 FOR EACH)	--	5	14456-KG2-950	SET PLATE, ROCKER ARM	1
(INC. REFACING)	--	6	14711-KBB-900	VALVE, INLET	1
(EXC. VALVE GUIDE REPLACEMENT)	--	7	14721-KBB-900	VALVE, EXHAUST	1
SPRING, VALVE	*3.4	8	14751-KEH-910	SPRING, VALVE OUTER	2
(ADD 0.1 FOR EACH )	--	9	14761-KEH-910	SPRING, VALVE INNER	2
(INC. RELATIVE PART)	--	10	14771-107-020	RETAINER, VALVE SPRING	2
		11	14775-107-000	SEAT, VALVE SPRING OUTER	2
		12	14776-107-010	SEAT, VALVE SPRING INNER	2
		13	14781-HA0-770	COTTER, VALVE	4
		14	90012-KN6-930L	SCREW, TAPPET ADJUSTING	2
		15	90206-250-000	NUT, TAPPET ADJUSTING	2
		16	93600-06016-0A	SCREW, FLAT, 6X16	1

**E-4**  
CAM CHAIN TENSIONER

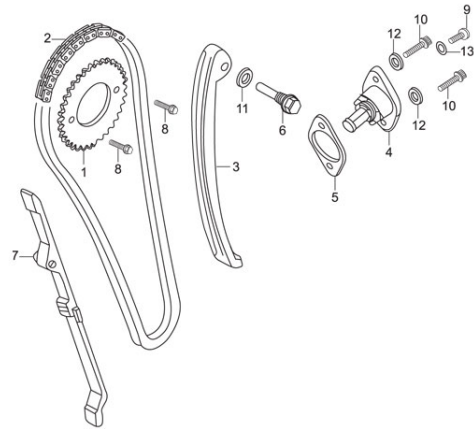

**FR.** ←



<b>Service Item</b>	<b>F.R.T.</b>	<b>Group Number: E-4 Model :: Karizma ZMR (May, 2014)</b>			
		<b>Ref No.</b>	<b>Part Number</b>	<b>Description</b>	<b>Req.</b>
SPROCKET, CAM (34T)	0.7	1	14321-KRY-970	SPROCKET CAM	1
CHAIN, CAM	1.6	2	14401-KFB-751	CHAIN, CAM	1
TENSIONER, CAM CHAIN	1.7	3	14500-KBB-900	TENSIONER, CAM CHAIN	1
LIFTER ASSY., TENSIONER	0.4	4	14520-KRY-971	LIFTER ASSY., TENSIONER (PRICOL)	1
GASKET, TENSIONER LIFTER	--	5	14523-KEH-910	GASKET, TENSIONER LIFTER	1
GUIDE, CAM CHAIN	*2.8	6	14535-437-000	BOLT, TENSIONER PIVOT	1
		7	14550-KFB-000	GUIDE, CAM CHAIN	1
		8	90002-KW1-900	BOLT, FLANGE, 6X10	2
		9	90005-KY7-000	SCREW, PAN, 6X6	1
		10	90071-MG8-000	BOLT, FLANGE, SOCKET 6X16	2
		11	90475-703-000	WASHER, C 8 MM	1
		12	90488-425-000	WASHER, SEALING 6 MM	2
		13	91306-MG3-000	O- RING, 1.5X9.5	1

**E-5**  
RIGHT CRANK CASE COVER

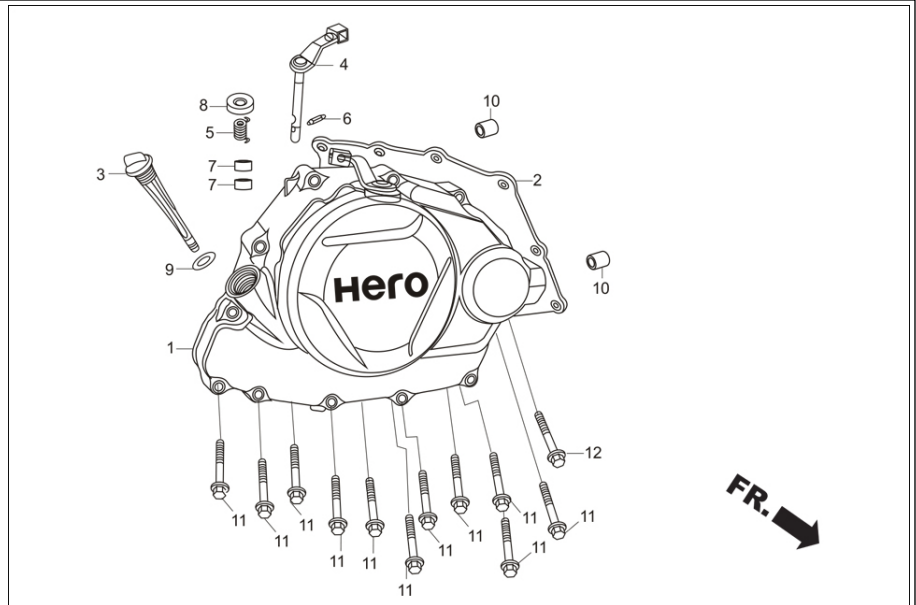

<b>Service Item</b>	<b>F.R.T.</b>	<b>Group Number: E-5 Model :: Karizma ZMR (May, 2014)</b>			
		<b>Ref No.</b>	<b>Part Number</b>	<b>Description</b>	<b>Req.</b>
COVER COMP., 'R' CRANK CASE	0.8	1	11330-AAR-H00	COVER COMP R CRANK CASE	1
LEVER COMP., CLUTCH	--	2	11393-KCN-010	GASKET, R COVER	1
GASKET, R CRANK CASE COVER	0.7	3	15650-KRY-970	GAUGE OIL LEVEL	1
OIL SEAL, 12 X 22 X 5	--	4	22810-KBB-900	LEVER COMP., CLUTCH	1
OIL SEAL, 16 X 28 X 7	0.6	5	22815-428-000	SPRING, CLUTCH LEVER	1
		6	90701-KFN-850	PIN, SPRING, 3 X 10	1
		7	91053-719-005	BRG.,NEEDLE,12X16X10	2
		8	91201-KEH-910	OIL SEAL, 12 X 22 X 5	1
		9	91307-KRM-840	O-RING, 18 X 3	1
		10	94301-08140	DOWEL PIN, 8X14	2
		11	96001-06040-00	BOLT, FLANGE, SH. 6 X 40	11
		12	96001-06050-00	BOLT, FLANGE, SH. 6 X 50	1

**E-6**  
CLUTCH

FR. 

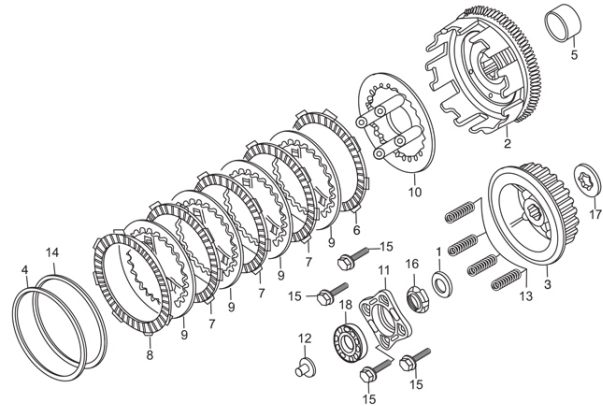

<b>Service Item</b>	<b>F.R.T.</b>	<b>Group Number: E-6 Model :: Karizma ZMR (May, 2014)</b>			
		<b>Ref No.</b>	<b>Part Number</b>	<b>Description</b>	<b>Req.</b>
OUTER COMP,CLUTCH	1.1	1	15451-KRY-970	WASHER LOCK 16MM	1
CENTER COMP., CLUTCH	--	2	22100-KRY-900R	OUTER COMP,CLUTCH	1
DISK, CLUTCH FRICTION	--	3	22121-KPK-900	CENTER COMP,CLUTCH	1
(ONE OR ALL)	--	4	22125-KW7-900	SEAT, JUDDER SPRING	1
(INC. RELATIVE PART)	--	5	22131-KPM-850	GUIDE,CLUTCH OUTER	1
PLATE, CLUTCH PRESSURE	--	6	22201-KBW-900	DISC,CLUTCH FRICTION	1
ROD,CLUTCH LIFTER	0.7	7	22201-KPM-850	DISK,CLUTCH FRICTION,4 X 8 X 45	3
		8	22201-MJ8-000	DISC, CLUTCH FRICTION	1
		9	22321-KE8-000	PLATE,CLUTCH	4
		10	22355-KPK-900	PLATE,CLUTCH PRESSURE	1
		11	22361-KPK-900	PLATE,CLUTCH LIFTER	1
		12	22366-KFB-000	ROD,CLUTCH LIFTER	1
		13	22401-KRY-900	SPRING,CLUTCH	4
		14	22402-KPM-850	SPRING,JUDDER	1
		15	90050-357-000	SPECIAL BOLT, FLANGE, 6X22	4
		16	90231-KB5-720	NUT, LOCK, 16 MM	1
		17	90461-KPK-900	WASHER,20 MM	1
		18	91008-KK6-000	BEARING, BALL RADIAL 16003	1

**E-7**  
LEFT CRANK CASE COVER

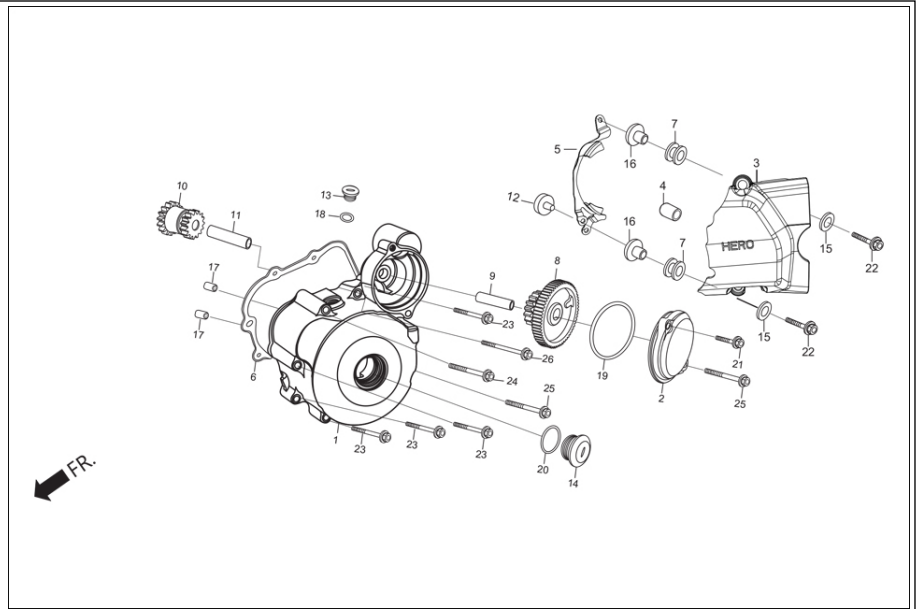

<b>Service Item</b>	<b>F.R.T.</b>	<b>Group Number: E-7 Model :: Karizma ZMR (May, 2014)</b>			
		<b>Ref No.</b>	<b>Part Number</b>	<b>Description</b>	<b>Req.</b>
COVER LEFT CRANK CASE	0.9	1	11341-KRY-970	COVER, LEFT CRANK CASE	1
COVER, REDUCTION GEAR	--	2	11355-KRY-970	COVER , REDUCTION GEAR	1
COVER, LEFT RR., CRANKCASE	0.1	3	11361-AAR-000	COVER LEFT REAR CRANK CASE	1
GASKET, LEFT COVER	0.6	4	11363-437-620	RUBBER, REAR COVER MOUNT	1
GEAR REDUCTION	--	5	11370-AAR-000	GUIDE COMP DRIVE CHAIN	1
SHAFT, IDLE GEAR	--	6	11395-KCN-010	GASKET, L COVER	1
		7	17622-GB7-900	RUBBER, CUSHION	2
		8	28130-KFB-000	GEAR, REDUCTION	1
		9	28132-KN6-930	SHAFT, REDUCTION GEAR	1
		10	28140-KFB-000	GEAR, IDLE (16T)	1
		11	28142-KW1-900	SHAFT, IDLE GEAR	1
		12	35752-KRY-900A	RUBBER, NEUTRAL SW.	1
		13	90084-KRY-970	CAP 14MM	1
		14	90087-KRY-970	CAP 30MM	1
		15	90417-041-000	WASHER, GEAR SHIFT DRUM SIDE	2
		16	90502-KEZ-900	COLLAR, RUBBER CUSHION	2
		17	90703-HC4-000	DOWEL PIN, 10X14	2
		18	91303-377-000	O-RING, 13.8 X 2.5	1
		19	91304-MZ0-760	O RING 63X3	1
		20	91356-KEH-910	O-RING, 30 MM	1
		21	96001-06020-00	BOLT, FLANGE, SH. 6 X 20	1
		22	96001-06028-00	BOLT, FLANGE, SH. 6X28	2
		23	96001-06040-00	BOLT, FLANGE, SH. 6 X 40	4
		24	96001-06060-00	BOLT, FLANGE, SH. 6 X 60	1
		25	96001-06070-00	BOLT, FLANGE, SH., 6X70	2
		26	96001-06080-00	BOLT, FLANGE, SH. 6 X 80	1

**E-7A**  
A.C. GEN. FLYWHEEL

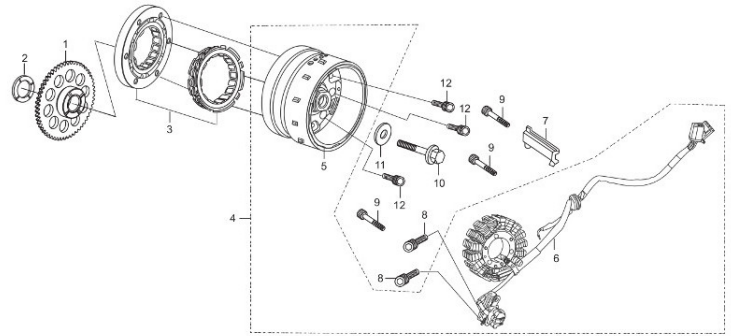

← FR.



<b>Service Item</b>	<b>F.R.T.</b>
GEAR COMP., STARTER DRIVEN	--
COLLAR, STARTER DRIVEN GEAR	--
OUTER COMP., STARTING CLUTCH	0.7
A.C.GEN., FLYWHEEL(ND)	0.9

<b>Group Number: E-7A Model :: Karizma ZMR (May, 2014)</b>				
<b>Ref No.</b>	<b>Part Number</b>	<b>Description</b>	<b>Req.</b>	
1	28110-KEW-900	GEAR COMP., STARTER DRIVEN	1	
2	28114-KN6-930	COLLAR, STARTER DRIVEN GEAR	1	
3	28125-KFC-791L	OUTER COMP., STARTING CLUTCH	1	
4	31100-AAR-001	A.C.GEN.FLYWHEEL	1	
5	31110-AAR-001	FLYWHEEL COMP.	1	
6	31120-KRY-971	STATOR COMP.	1	
7	32975-KRY-970	GUIDE ACG CORD	1	
8	90089-KAS-900	BOLT, FLANGE SOCKET, 5X14	2	
9	90092-KE5-000	BOLT, STOPPER TENSIONER SHAFT	3	
10	90101-AAP-000	BOLT, FLANGE, 10 X 65	1	
11	90403-KN6-930	WASHER, 10X24	1	
12	96700-06032-10	BOLT, SOCKET, 6X32	6	

**E-7B**  
STARTER MOTOR

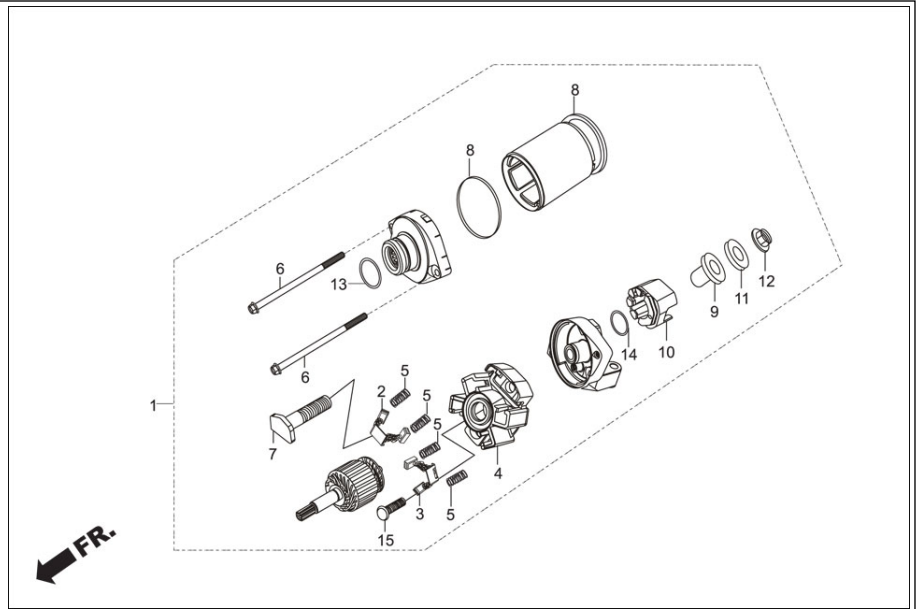

<b>Service Item</b>	<b>F.R.T.</b>	<b>Group Number: E-7B Model :: Karizma ZMR (May, 2014)</b>			
MOTOR ASSY., STARTER	0.7	<b>Ref No.</b>	<b>Part Number</b>	<b>Description</b>	<b>Req.</b>
		1	31200-KPS-A11	MOTOR ASSY STARTER	1
		2	31201-MEW-921	CARBON BRUSH SET A	1
		3	31202-MEW-921	CARBON BRUSH SET B	1
		4	31203-MEW-921	BRUSH HOLDER	1
		5	31204-MEW-921	SPRING CARBON BRUSH	4
		6	31205-HP5-601	BOLT SET	2
		7	31206-MEW-921	TERMINAL BOLT	1
		8	31207-HP5-601	RING	2
		9	31208-MEW-921	INSULATOR	1
		10	31209-MEW-921	TERMINAL STOPPER	1
		11	31210-MEW-921	WASHER	1
		12	90071-MB0-000	NUT, WASHER, 6 MM	1
		13	91309-425-003	O RING 24.4X3.1	1
		14	91320-MB0-000	O RING	1
		15	93892-05012-18L	SCREW WASH 5X12	1

# E-8

## CRANK CASE

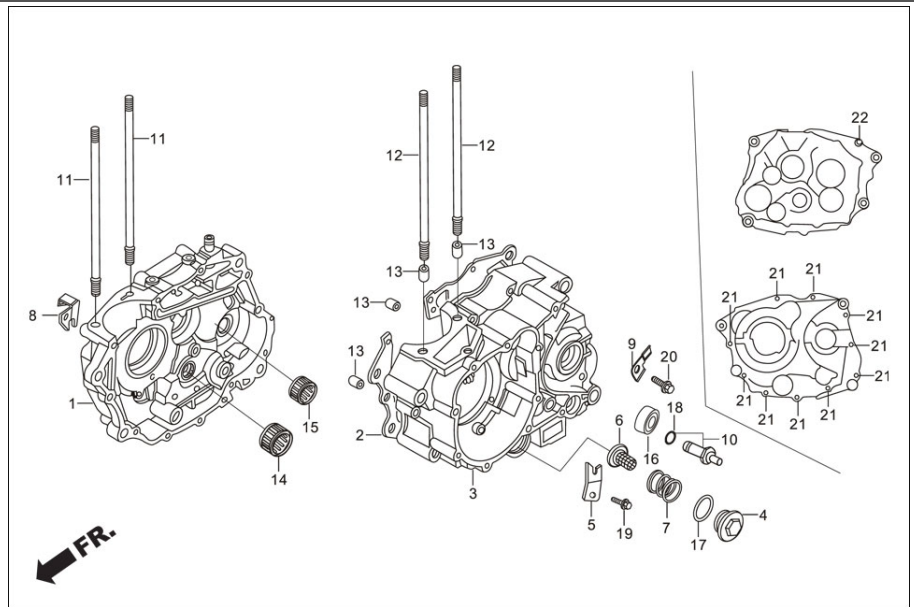

<b>Service Item</b>	<b>F.R.T.</b>	<b>Group Number: E-8 Model :: Karizma ZMR (May, 2014)</b>			
		<b>Ref No.</b>	<b>Part Number</b>	<b>Description</b>	<b>Req.</b>
CRANK CASE COMP., RIGHT	*4.9	1	11100-KRY-970	CRANK CASE COMP. RIGHT	1
GASKET, CRANK CASE	*4.4	2	11191-KCN-010	GASKET, CRANK CASE	1
CRANK CASE COMP., LEFT	*5.8	3	11200-KRY-960	CRANK CASE COMP., LEFT	1
SCREEN, OIL FILTER	0.1	4	12361-KEZ-900	HOLE CAP, TAPPET ADJUSTING	1
(INC. RELATIVE PART)	--	5	14513-KBB-900	PLATE, CAM CHAIN SET	1
		6	15421-107-000	SCREEN, OIL FILTER	1
		7	15426-107-000	SPRING, OIL FILTER SCREEN	1
		8	22838-437-000	HOLDER, CLUTCH WIRE	1
		9	32976-KCT-690	CLAMPER, WIRE HARNESS	1
		10	35750-KCS-920	CONTACT, NEUTRAL SWITCH	1
		11	90031-KFB-000L	BOLT, A STUD CYLINDER	2
		12	90032-KFB-000	BOLT B STUD CYLINDER	2
		13	90703-HC4-000	DOWEL PIN, 10X14	4
		14	91008-KCS-920	BEARING, NEEDLE, 21 MM	1
		15	91106-KCS-920	BEARING, NEEDLE, 15 MM	1
		16	91206-KCS-920	OIL SEAL, 14X28X4.	1
		17	91303-KCS-920	O-RING, 35X3	1
		18	91312-107-000	O -RING, 7 X 1.7	1
		19	95701-06012-00	BOLT, FLANGE, 6X12	1
		20	96001-06014-00	BOLT, FLANGE, SH. 6 X 14	1
		21	96001-06050-00	BOLT, FLANGE, SH. 6 X 50	10
		22	96001-06060-00	BOLT, FLANGE, SH. 6 X 60	1

# E-8A OIL PUMP

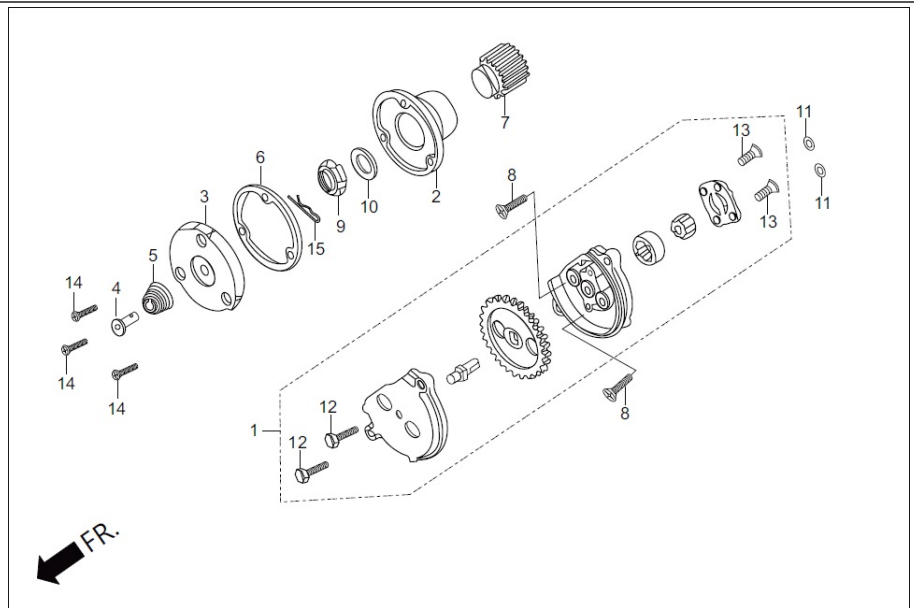

<b>Service Item</b>	<b>F.R.T.</b>	<b>Group Number: E-8A Model :: Karizma ZMR (May, 2014)</b>			
		<b>Ref No.</b>	<b>Part Number</b>	<b>Description</b>	<b>Req.</b>
* OIL PUMP ASSY	0.9	1	15100-AAR-101	OIL PUMP ASSY	1
* ROTOR COMP., OIL FILTER			15100-AAR-101	OIL PUMP ASSY	1
* CAP, OIL FILTER ROTOR		2	15430-440-030	ROTOR COMP., OIL FILTER	1
* GEAR, PRIMARY DRIVE	1.1	3	15436-107-000	CAP, OIL FILTER ROTOR	1
		4	15441-KCS-650	OIL, THROUGH	1
		5	15446-107-000	SPRING, OIL THROUGH	1
		6	15459-KWK-900	GASKET ,OIL FILTER CAP	1
		7	23121-KBB-900	GEAR, PRIMARY DRIVE (22T)	1
		8	90101-440-000	SCREW, FLAT, 6X30	2
		9	90231-KCS-920	NUT, LOCK, 16 MM	1
		10	90434-KN6-930	WASHER, 16 MM	1
		11	91304-KK3-830	O-RING, 9.4X2.4	2
		12	92101-05020-0A	BOLT, HEX., 5X20	2
		13	93600-04012-0A	SCREW, FLAT, 4X12	2
		14	93700-05012-0A	SCREW, OVAL, 5X12	3
		15	94251-08000	PIN LOCK, 8 MM	1

**E-9**  
CRANK SHAFT / PISTON

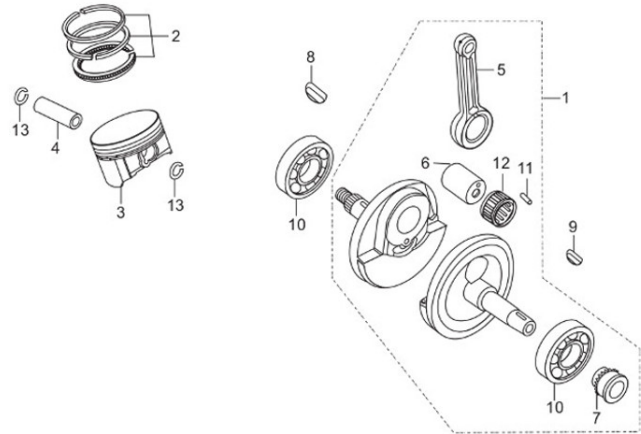



<b>Service Item</b>	<b>F.R.T.</b>
CRANK SHAFT,COMP	*5.3
RING SET,PISTON(STD)	*3.2
PISTON	--
PIN, PISTON	*3.1
ROD, CONNECTING(ACTUAL TIME)	--
(INC. RELATIVE PART)	--
BRG. BALL RADIAL, 28 X 72 X 18	*4.6

<b>Group Number: E-9 Model :: Karizma ZMR (May, 2014)</b>				
<b>Ref No.</b>	<b>Part Number</b>	<b>Description</b>	<b>Req.</b>	
1	13000-KRY-903	CRANK SHAFT,COMP	1	
2	13011-KRY-900	RING SET,PISTON(STD)	1	
3	13101-AAR-001	PISTON	1	
4	13111-440-000	PIN, PISTON	1	
5	13201-KFB-300	ROD CONNECTING	1	
6	13380-KCN-300	PIN COMP,CRANK	1	
7	14311-KN6-931L	SPROCKET, TIMING	1	
8	90471-KW1-900	KEY,WOODRUFF,25 X 18	1	
9	90741-KFB-000	KEY,WOODRUFF,4 MM	1	
10	91001-KCN-003	BRG. BALL RADIAL, 28 X 72 X 18	2	
11	91102-KC6-003	ROLLER,4 X 14.8 A	18	
	91103-KC6-003	ROLLER, 4 X 14.8 B	18	
	91104-KC6-003	ROLLER, 4 X 14.8 C	18	
12	91105-KW3-003	RETAINER, CONROD L END	1	
13	94601-15000	CLIP,PISTON PIN,15 MM	2	

**E-10**  
TRANSMISSION (MAIN SHAFT / COUNTER  
SHAFT & GEARS)

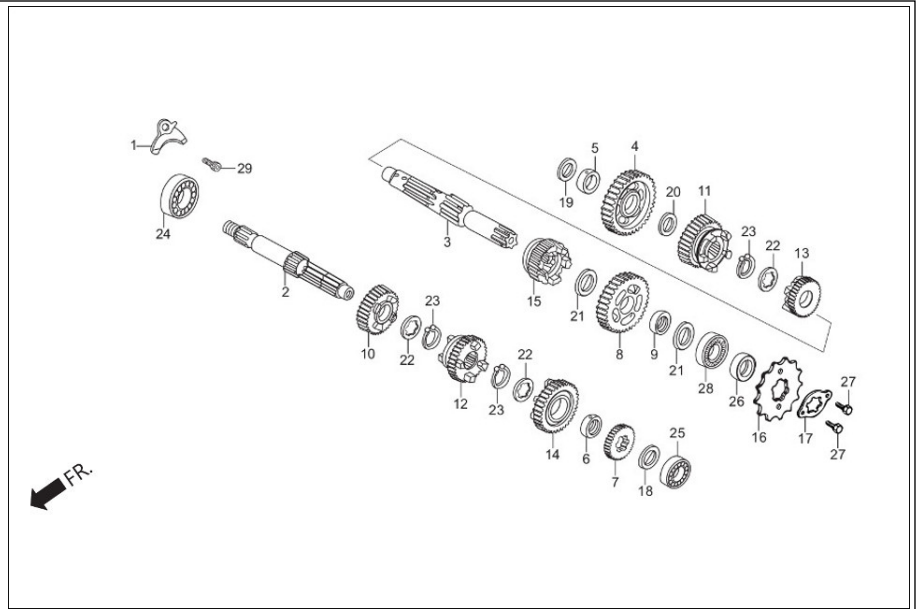

<b>Service Item</b>	<b>F.R.T.</b>	<b>Group Number: E-10 Model :: Karizma ZMR (May, 2014)</b>			
		<b>Ref No.</b>	<b>Part Number</b>	<b>Description</b>	<b>Req.</b>
MAIN SHAFT	*5.3	1	11108-KHA-940	PLATE BEARING SET	1
(INC. RELATIVE PART)	--				
COUNTER SHAFT	*4.8	2	23211-KHA-940	SHAFT, MAIN TRANSMISSION	1
(INC. RELATIVE PART)	--	3	23221-AAR-000	SHAFT COUNTER TRANSMISSION	1
(WHEN SERVICING COMP UNIT)	--	4	23426-KBB-900	GEAR C1 ( 36T )	1
SPROCKET, DRIVE	*0.2	5	23427-KW1-900	BUSH, 16.5 X 19.5 X 9	1
		6	23431-KRY-900	BUSH, 20 MM	1
		7	23441-KBB-900	GEAR, M2 (18T )	1
		8	23451-KRY-970	GEAR C-2 (31T)	1
		9	23452-KW1-900	BUSH 20X23X9	1
		10	23461-KBB-900	GEAR , M3 ( 19T )	1
		11	23471-KBB-900	GEAR, C3 (24 T )	1
		12	23481-KBB-900	GEAR , M4 ( 22 T )	1
		13	23491-KBB-900	GEAR, C4 ( 22T )	1
		14	23501-KRY-900	GEAR M5 (27 T )	1
		15	23511-KRY-970	GEAR C-5 (22T)	1
		16	23801-KRY-970	SPROCKET DRIVE 13T	1
		17	23811-KR3-600	PLATE, A2 FIXING	1
		18	90451-107-000	WASHER THRUST, 15MM	1
		19	90451-365-000	WASHER THRUST, 15MM	1
		20	90452-437-000	WASHER THRUST, 16.5 MM	1
		21	90454-107-000	WASHER ,THRUST, 20MM	2
		22	90455-107-000	WASHER A SPLINE, 20MM	3
		23	90605-200-000	SET RING, 20MM	1
		24	91005-KCN-003	BRG. BALL RADIAL, 20 X 55 X 11	1
		25	91015-KEH-910	BEARING, BALL RADIAL, 6202U	1
		26	91201-KCS-920	OIL SEAL, 20X34X7	1
		27	92101-06010-0A	BOLT, HEX., 6 X 10	2
		28	96100-62040-00	BEARING, BALL RADIAL, 6204	1

29	96600-08018-18	BOLT, SOCKET, 8 X 18	1
----	----------------	----------------------	---

**E-12**  
GEAR SHIFT DRUM

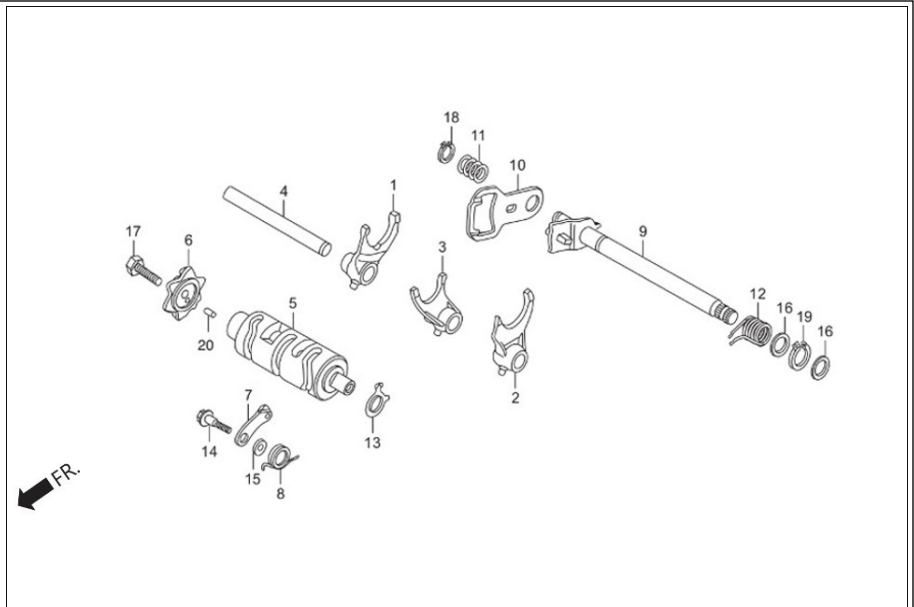

<b>Service Item</b>	<b>F.R.T.</b>	<b>Group Number: E-12 Model :: Karizma ZMR (May, 2014)</b>			
FORK, GEAR SHIFT (ONE OR ALL)	*4.4 --	<b>Ref No.</b>	<b>Part Number</b>	<b>Description</b>	<b>Req.</b>
DRUM, GEAR SHIFT	--	1	24211-KW1-900	FORK RIGHT, GEAR SHIFT	1
CAM, GEAR SHIFT	1.2	2	24221-KBB-900	FORK LEFT, GEAR SHIFT	1
STOPPER COMP., GEARSHIFT DRUM (INC. RELATIVE PART)	0.8 --	3	24231-KW1-900	FORK CENTER, GEAR SHIFT	1
PLATE, GEAR SHIFT	--	4	24241-KCS-650	SHAFT, GEAR SHIFT FORK GUIDE	1
SPINDEL COMP., GEAR SHIFT	0.9	5	24301-KCN-000	DRUM, GEAR SHIFT	1
		6	24411-KCN-000	CAM, GEAR SHIFT	1
		7	24430-KW1-900	STOPPER COMP., GEAR SHIFT DRUM	1
		8	24435-KCN-000	SPRING, SHIFT DRUM STOPPER	1
		9	24610-KC6-000	SPINDLE COMP., GEAR SHIFT	1
		10	24621-107-760	PLATE, GEAR SHIFT	1
		11	24631-107-000	SPRING, GEAR SHIFT PLATE	1
		12	24651-107-000	SPRING, GEAR SHIFT RETURN	1
		13	35753-KCS-920	ROTOR, NEUTRAL SWITCH	1
		14	90023-KW1-900	PIVOT, SHIFT DRUM STOPPER	1
		15	90408-KW1-900	WASHER, 6 MM	1
		16	90451-001-000	WASHER, THRUST, 14 MM	2
		17	92000-06025-0A	BOLT, HEX., 6 X 25	1
		18	94510-12000L	CIRCLIP, EXTERNAL, 12 MM	1
		19	94510-14000	CIRCLIP, EXTERNAL, 14 MM	1
		20	96220-40100	ROLLER, 4X10	1

**E-13**  
INJECTOR ASSY., FUEL

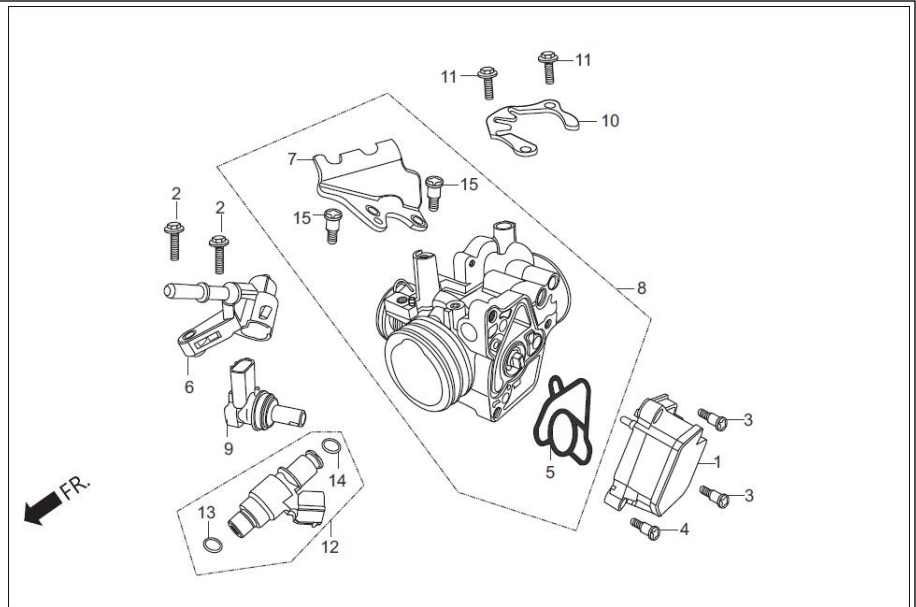

Service Item	F.R.T.	Group Number: E-13 Model :: Karizma ZMR (May, 2014)			
		Ref No.	Part Number	Description	Req.
		1	16060-AAR-001	SENSOR SET	1
		2	16080-AAR-001	BOLT FLANGE 5X20	2
		3	16081-AAR-001	SCREW TORX 5X8.7	2
		4	16082-AAR-001	SCREW TOR 5X17	1
		5	16083-AAR-001	O-RING,THROTTLE BODY	1
		6	16422-AAR-001	JOINT INJECTOR	1
		7	16169-AAR-001	STAY,WIRE	1
		8	16410-AAR-001	BODY SET	1
		9	16430-AAR-001	IACV SET	1
		10	16432-AAR-001	PLATE, IACV	1
		11	16433-AAR-001	SCREW, TORX	2
		12	16460-AAR-001	INJECTOR ASSY FUEL	1
		13	16472-AAR-001	SEAL RING INJECTOR	1
		14	91301-AAR-001	O-RING, 6.3 X 2.2	1
		15	93892-AAR-001	SCREW WASHER , 5 X 12	2



**F-1**  
HEAD LIGHT

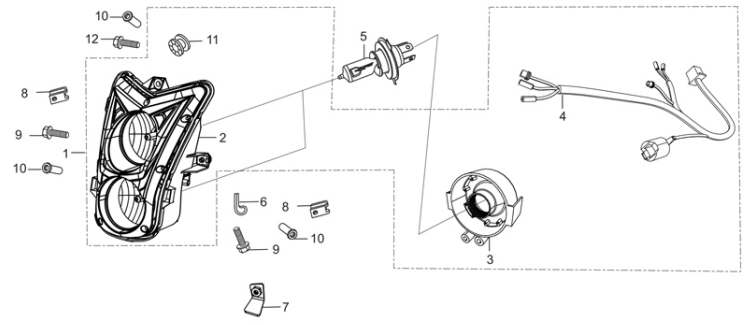

<b>Service Item</b>	<b>F.R.T.</b>	<b>Group Number: F-1 Model :: Karizma ZMR (May, 2014)</b>			
		<b>Ref No.</b>	<b>Part Number</b>	<b>Description</b>	<b>Req.</b>
* LIGHT ASSY., HEAD	--	1	3310B-AAR-001	LIGHT ASSY.HEAD(W/O BULB)	1
* SOCKET COMP.,	--	2	33110-AAP-001	UNIT HEAD LIGHT	1
* BULB, HEAD LIGHT	--	3	33112-AAP-001	DUST COVER	2
*BULB, WEDGE BASE	--	4	33150-AAR-001	SOCKET COMP	1
* PLATE, FRONT NUMBER	--	5	34901-AAP-001	BULB (H8)	2
* STAY FR., NUMBER PLATE	--	6	37215-AAP-001	PVC CAMPING STRIP	1
* COWL CENTRE FRONT	--	8	90344-KEV-900	NUT C CLIP 6MM	2
		9	90105-KVN-900	BOLT, SPECIAL 6 X 22	3
		10	19052-KV0-000	COLLAR, RADIATOR MTG	3
		11	83545-KCJ-690	RUBBER, SIDE COVER	1

**F-1A**  
FRONT COWL

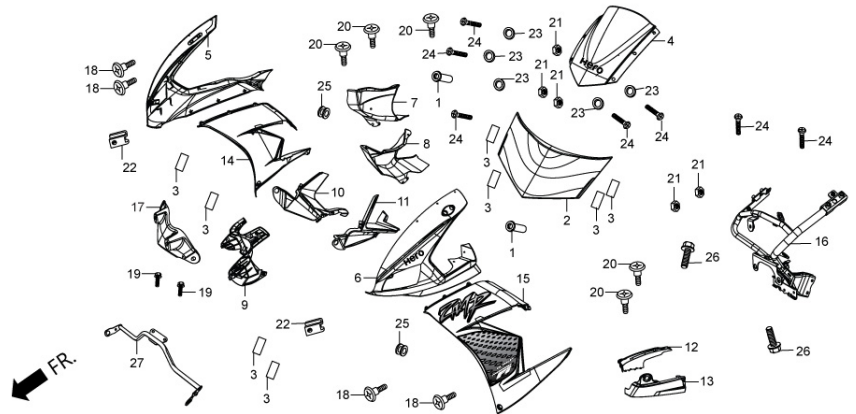

<b>Service Item</b>	<b>F.R.T.</b>	<b>Group Number: F-1A Model :: Karizma ZMR (May, 2014)</b>			
		<b>Ref No.</b>	<b>Part Number</b>	<b>Description</b>	<b>Req.</b>
COWL, CENTER FR.	--	1	19052-KV0-000	COLLAR, RADIATOR MTG	2
SCREEN, FRONT	--	2	61301-AAR-000	TRIM PANEL FRONT FAIRING	1
COWL R/L INNER LWR	--	3	61309-AAR-000	CUSHION WIND SCREEN	8
COWL R/L INNER UPPER	--	4	64100-AAR-000	WIND SCREEN	1
PANEL R/L INNER	--	5	64200-AAR-000R	FAIRING FR R. SIDE(PBM,NH-B08M)	1
			64200-AAR-000S	FAIRING FRONT R SIDE(PFW,NH-341P)	1
			64200-AAR-000T	FAIRING FR R. SIDE(CBR,R-195C)	1
			64200-AAR-000U	FAIRING FR R. SIDE(VOR,YR-250)	1
		6	64258-AAR-000R	SET, FR FAIRNG L SIDE(PBM,NH-B08M)	1
			64258-AAR-000S	SET, FR FAIRNG L SIDE(PFW,NH-341P)	1
			64258-AAR-000T	SET, FR FAIRNG L SIDE(CBR,R-195C)	1
			64258-AAR-000U	SET, FR FAIRNG L SIDE(VOR,YR-250)	1
		7	64301-AAR-000	AIR DUCT ENGINE COOLING RIGHT	1
		8	64302-AAR-000	AIR DUCT ENGINE COOLING LEFT	1
		9	64305-AAR-000	DASH PANEL	1
		10	64206-AAR-000	AIR DUCT HEAT DEFLECTOR RIGHT	1
		11	64207-AAR-000	AIR DUCT HEAT DEFLECTOR LEFT	1
		12	64320-AAR-000	BELLY PAN RIGHT SIDE	1
		13	64330-AAR-000	BELLY PAN LEFT SIDE	1
		14	64348-AAR-000R	SET, R FAIRING SIDE(PBM,NH-B08M)	1
			64348-AAR-000S	SET, R FAIRING SIDE(PFW,NH-341P)	1
			64348-AAR-000T	SET, R FAIRING SIDE(CBR,R-195C)	1
			64348-AAR-000U	SET, R FAIRING SIDE(VOR,YR-250)	1
		15	64358-AAR-000R	SET, L FAIRING SIDE(PBM,NH-B08M)	1
			64358-AAR-000S	SET, L FAIRING SIDE(PFW,NH-341P)	1
			64358-AAR-000T	SET, L FAIRING SIDE(CBR,R-195C)	1
			64358-AAR-000U	SET, L FAIRING SIDE(VOR,YR-250)	1
		16	64510-AAR-000	FAIRING SUPPORT BRKT ASSY	1

17	64315-AAR-000	LICENSE PLATE BRACKET FRONT	1
18	90105--KRY-970	SCREW, FAIRING A (5X11.5	4
19	90105-KVN-900	BOLT, SPECIAL 6 X 22	2
20	90109-SB6-000	SCREW, TRUSS, 5X14	5
21	90111-KW3-000	NUT COWL SET M5X0.8	5
22	90320-GC3-000	NUT, SPRING, M5	2
23	90504-964-000	WASHER, THRUST, 5MM	5
24	93903-25210	SCREW, TAPPING, 5X12	7
25	83551-300-000	GROMMET, AIR CLEANER CASE	2
26	95701-06025-00	BOLT, FLANGE, 6X 25	2
27	64523-AAR-000	SUPPORT SIDE FAIRING CTR	1

**F-1C**  
COOLER COMP., OIL

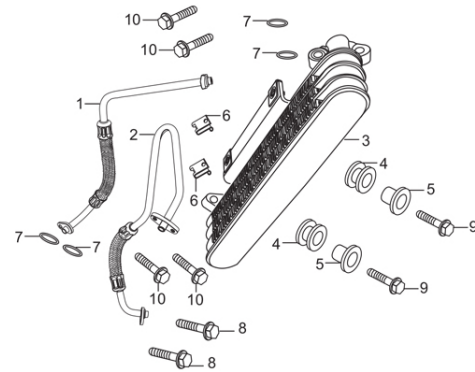

FR.

<b>Service Item</b>	<b>F.R.T.</b>	<b>Group Number: F-1C Model :: Karizma ZMR (May, 2014)</b>			
COOLER COMP., OIL	--	<b>Ref No.</b>	<b>Part Number</b>	<b>Description</b>	<b>Req.</b>
		1	15510-KRY-970	OIL HOSE, A	1
		2	15520-KRY-970	OIL HOSE, B	1
		3	15600-AAR-000	OIL COOLER ASSEMBLY	1
		4	19051-KA3-830	RUBBER, RAD MT	2
		5	19052-MN8-000	COLLAR, RAD MT	2
		6	90301-KRY-970	NUT CLIP 6 MM.	2
		7	91314-ME5-003	O-RING, 10 X 2.6	4
		8	95701-06016-07	BOLT, FLANGE, 6 X 16	2
		9	95701-06025-00	BOLT, FLANGE, 6X 25	2
		10	96001-06020-00	BOLT, FLANGE, SH. 6 X 20	4

**F-2**  
SPEEDOMETER

FR.

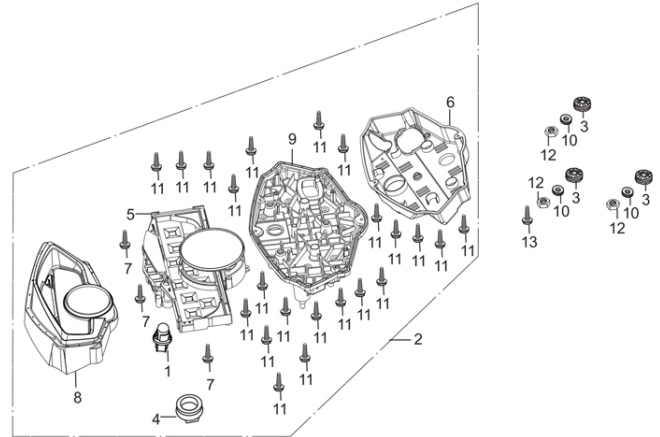



<b>Service Item</b>	<b>F.R.T.</b>	<b>Group Number: F-2 Model :: Karizma ZMR (May, 2014)</b>			
		<b>Ref No.</b>	<b>Part Number</b>	<b>Description</b>	<b>Req.</b>
* METER ASSY., COMB.	--	1	35505-SA5-003	BULB SOCKET ASSY.	1
* COVER UPPER	--	2	37100-AAR-001	METER ASSY.COMB.	1
* CASE UNDER ASSY.	--	3	37105-KRY-970	RUBBER METER SET	3
* CASE UPPER ASSY.	--	4	37105-KRJ-901	CAP	1
* CABLE ASSY., SPEEDOMETER	--	5	37110-AAR-001	METER COMP COMB	1
* CABLE COMP., INNER	--	6	37112-KRY-971	COVER	1
		7	37214-KV7-671	SCREW, TAPPING, 3 X 12	3
		8	37612-KRY-981	CASE, UPPER ASSY	1
		9	37613-KRY-971	CASE UNDER ASSY	1
		10	90501-KRY-970	WASHER, PLAIN, 6X18	3
		11	93903-22420	SCREW,TAPPING,3 X 16	22
		12	94001-06000-0S	NUT, HEX., 6 MM	3
		13	93600-04012-1GL	SCREW FLAT 4X12	1

# F-3

## FRONT BRAKE MASTER CYL

FR.

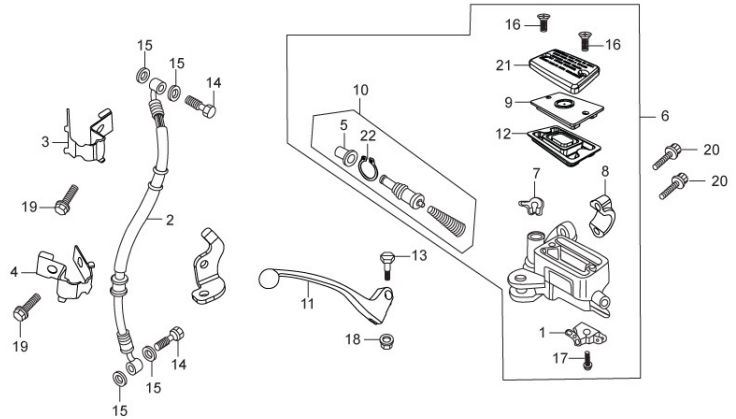

<b>Service Item</b>	<b>F.R.T.</b>	<b>Group Number: F-3 Model :: Karizma ZMR (May, 2014)</b>			
		<b>Ref No.</b>	<b>Part Number</b>	<b>Description</b>	<b>Req.</b>
SWITCH ASSY., FR. STOP	0.1	1	35340-MA5-670L	SW. ASSY. FR. STOP	1
DIAPHRAGM.	--	2	45126-KRY-970	HOSE COMP. FR. BRAKE	1
LEVER 'R' STEERING HANDLE	--	3	45155-KRY-970	CLAMPER FR BRAKE	1
HOSE COMP., FR. BRAKE	0.4	4	45156-KRY-900	CLAMPER, BRAKE HOSE	1
CYL. SUB. ASSY. FR. BRAKE MASTER	--	5	45504-410-003L	BOOT COMP.	1
CYLINDER SET, MASTER	--	6	45510-KRY-972	M/C SUB ASSY., FRONT BRAKE	1
		7	45512-MA6-006	PROTECTOR	1
		8	45517-166-000	HOLDER, MASTER CYLINDER	1
		9	45521-K21-901	PLATE, DIAPHRAGM	1
		10	45530-471-831L	CYLINDER SET MASTER	1
		11	53175-KFN-850L	LEVER, RIGHT STRG. HANDLE	1
		12	45520-GE2-006	DIAPHRAGM	1
		13	90114-166-000L	BOLT HANDLE LEVER	1
		14	90145-MS9-610	OIL BOLT, 10 X 22	2
		15	90545-300-000	WASHER ,OIL BOLT	4
		16	93600-04012-1GL	SCREW FLAT 4X12	2
		17	93893-04012-17L	SCREW WASHER 4X12	1
		18	94050-06000	NUT, FLANGE, 6 MM	1
		19	96001-06012-07	BOLT, FLANGE, SH., 6 X 12	1
		20	96001-06022-07	BOLT, FLANGE, SH.6X22	1
		21	45513-HA2-006L	CAP M/C	1
		22	90651-MA5-671L	CIRCLIP	1

**F-3A**  
HANDLE LEVER / SWITCH / CABLE

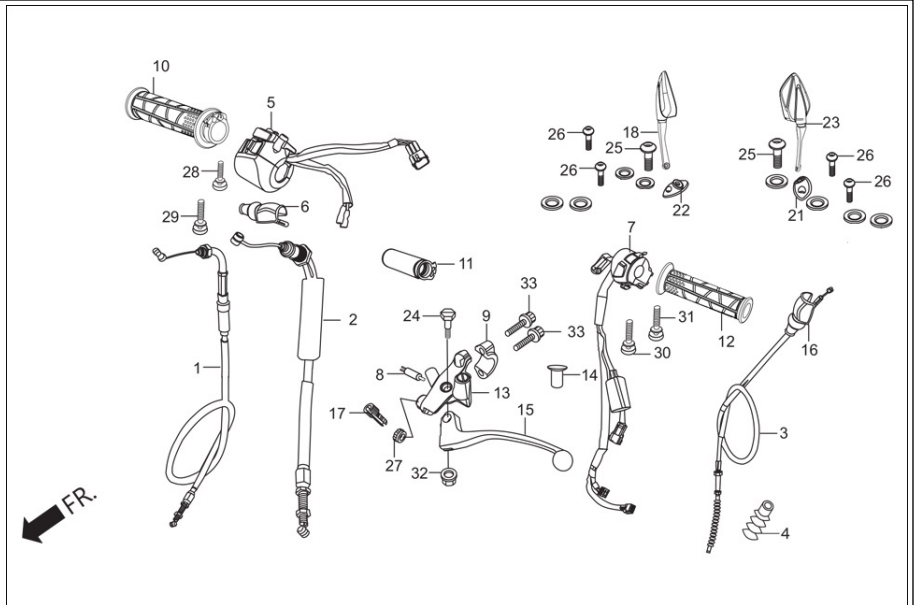

<b>Service Item</b>	<b>F.R.T.</b>	<b>Group Number: F-3A Model :: Karizma ZMR (May, 2014)</b>			
		<b>Ref No.</b>	<b>Part Number</b>	<b>Description</b>	<b>Req.</b>
*CABLE COMP., 'A' THROTTLE	--	1	17910-AAR-000	CABLE COMP A THROT	1
*CABLE COMP., 'B' THROTTLE	--	2	17920-AAR-000	CABLE COMP B THROT	1
* CABLE COMP., CHOKE	--	3	22870-KRY-970	CABLE COMP CLUTCH	1
* CABLE COMP., CLUTCH	--	4	22871-437-000	BOOT, CLUTCH WIRE	1
* SW. COMP., FR. LEVER	--	5	35150-KRY-971	SW. ASSY, LI. ST	1
* GRIP COMP., THROTTLE	0.6	6	35152-KRY-970	COVER CLUTCH SW.TERMINAL	1
* GRIP 'L' HANDLE	0.6	7	35200-KRY-971	SW. ASSY. WINKER	1
* LEVER COMP., 'L' HANDLE	--	8	35330-413-003	SW. COMP., FR. LEVER	1
		9	45517-166-000	HOLDER, MASTER CYLINDER	1
		10	53140-KRY-980	GRIP COMP., THROT	1
		11	53141-KRY-970	PIPE,THROTTLE GRIP	1
		12	53166-KRY-980	GRIP L. HANDLE	1
		13	53172-KRY-970	BRKT, HNDL LEVER	1
		14	53174-116-670	PLUG HANDLE LEVER	1
		15	53178-KFN-850	LEVER COMP., L HANDLE	1
		16	53182-KFN-850	BOOT, L HANDLE LEVER	1
		17	53192-349-690	BOLT WIRE ADJUST	1
		18	88110-AAR-H81ZA	MIRROR ASSY R BACK(NH-B08M,PANTHER BLACK METALLIC)	1
			88110-AAR-H81ZB	MIRROR ASSY R BACK(NH-341P(T1),PEARL FADELESS WHITE (TYPE-1)	1
			88110-AAR-H81ZC	MIRROR ASSY R BACK(CANDY BLAZING RED, R-195C)	1
			88110-AAR-H81ZD	MIRROR ASSY R BACK(YR-250,VIBRANT ORANGE)	1
		21	88115-KRY-970	BASE, R BACK MIRROR	1
		22	88116-KRY-970	BASE, L BACK MIRROR	1
		23	88120-AAR-H81ZA	MIRROR ASSY L BACK(NH-B08M,PANTHER BLACK METALLIC)	1
			88120-AAR-H81ZB	MIRROR ASSY L BACK(NH-341P(T1),PEARL FADELESS WHITE (TYPE-1)	1

	88120-AAR-H81ZC	MIRROR ASSY L BACK(CANDY BLAZING RED, R-195C)	1
	88120-AAR-H81ZD	MIRROR ASSY L BACK(YR-250,VIBRANT ORANGE)	1
24	90113-438-000	BOLT, HANDLE LEVER PIVOT	1
25	90128-KRY-970	BOLT BUTTAN 8X27	2
26	90130-MEE-000	BOLT, SOCKET 6 X 13	4
27	90321-MR8-000	NUT FIXING	1
28	93892-05020-07	SCREW, WASHER, 5X20	1
29	93892-05025-07	SCREW, WASHER, 5X25	1
30	93892-05035-07	SCREW, WASHER, 5X35	1
31	93892-05045-07	SCREW, WASHER, 5X45	1
32	94050-06000	NUT, FLANGE, 6 MM	1
33	96001-06022-07	BOLT, FLANGE, SH.6X22	2

**F-4**  
HANDLE PIPE / TOP BRIDGE / KEY SET

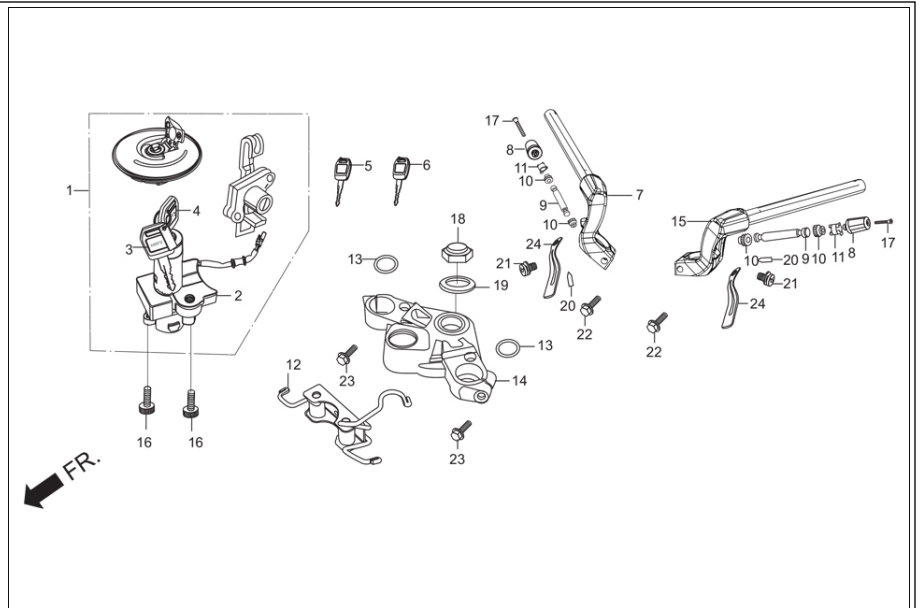

<b>Service Item</b>	<b>F.R.T.</b>	<b>Group Number: F-4 Model :: Karizma ZMR (May, 2014)</b>			
		<b>Ref No.</b>	<b>Part Number</b>	<b>Description</b>	<b>Req.</b>
KEY SET	--	1	35010-AAR-H70	KEY-SET	1
SW. ASSY., COMB. & LOCK	--	2	35100-AAR-H71	SWITCH ASSY COMB & LOCK	1
PIPE STEERING HANDLE	--	3	35113-KZJ-H00	EMBLEM ICON	1
BRIDGE, FORK TOP	--	4	35114-KZJ-H00	EMBLEM,WORD MARK	1
		5	35121-KZJ-H00	BLANK KEY NO.1	1
		6	35122-KZJ-H00	BLANK KEY NO.2	1
		7	5310B-AAR-000	HANDLE BAR & CLAMP ASSEMBLY RIGHT	1
		8	53104-KRY-970	WEIGHT, STRG. HNDL	2
		9	53105-KRY-970	WEIGHT B, STRG. HNDL	2
		10	53107-KTT-910	RUBBER, HNDL WT. B	2
		11	53108-MJ0-000	SNAPRING, HNDL. WT	2
		12	53127-KRY-970	GUIDE, COMP. CABLE	1
		13	53128-KRY-970	RUBBER, HNDL SEAT	2
		14	53230-KRY-970	BRIDGE FORK TOP	1
		15	5315B-AAR-000	HANDLE BAR & CLAMP ASSEMBLY LEFT	1
		16	90100-KRY-970	BOLT, SOCKET 8X50	2
		17	90191-KRY-970	BOLT, SOCKET 6X75	2
		18	90304-KSP-900	NUT, STEERING STEM	1
		19	90503-KTR-900	WASHER, STEERING STEM	1
		20	90751-KRY-970	DOWEL PIN,4 X 29.8	2
		21	93891-05008-00	SCREW WASH 5X8	2
		22	95701-08035-00	BOLT, FLANGE, 8 X 35	2
		23	95801-10040-02	BOLT, FLANGE 10 X 40	2
		24	90601-GFC-780	CLIP 4 X 60	2



**F-5**  
STEERING STEM

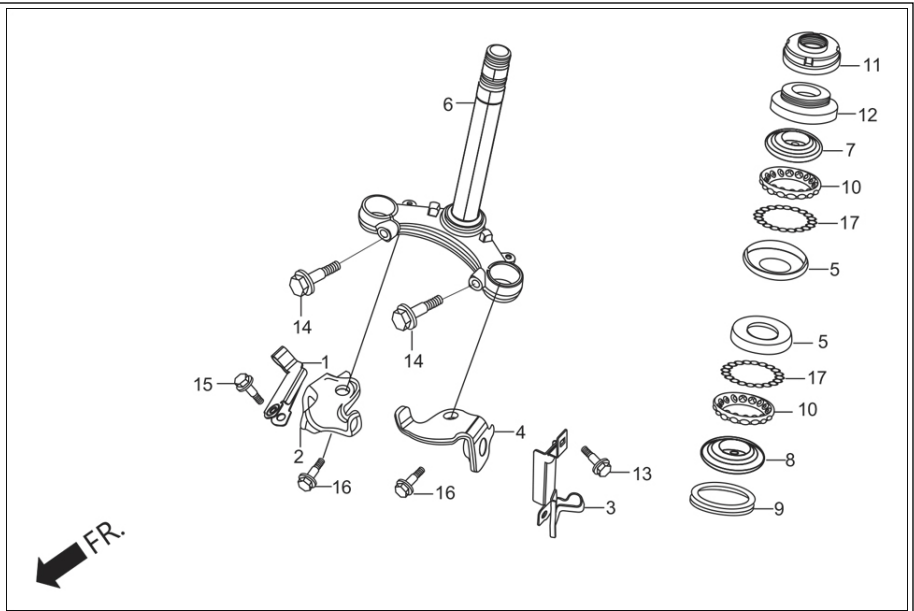

<b>Service Item</b>	<b>F.R.T.</b>	<b>Group Number: F-5 Model :: Karizma ZMR (May, 2014)</b>			
		<b>Ref No.</b>	<b>Part Number</b>	<b>Description</b>	<b>Req.</b>
RACE, STEERING BALL (ONE OR ALL)	1 --	1	45155-KRY-970	CLAMPER FR BRAKE	1
RACE, STEERING BOTTOM CONE	--	2	45160-KRY-970	STAY COMP CLAMPER BRK HOSE	1
STEM, COMP.,STEERING	1.1	3	45165-KRY-970	CLAMPER SENSOR CORD	1
RACE, STEERING TOP CONE	0.5	4	45170-KRY-970	STAY COMP CLAMPER SENSOR CORD	1
THREAD COMP. STRG.HD. TOP	--	5	50301-KTR-900	RACE, STEERING BALL	2
		6	53200-KRY-970	STEM COMP., STEERING	1
		7	53211-268-010	RACE, STEERING TOP CONE	1
		8	53212-200-000	RACE, STEERING BOTTOM CONE	1
		9	53214-200-000	DUST SEAL, STEERING HEAD	1
		10	53215-KTR-900	BALL, ASSY. STEERING	2
		11	53220-KRY-970	THREAD COMP STRG TOP.	1
		12	53222-KTR-900	MUD GUARD, STEERING HEAD TOP	1
		13	95701-06012-07	BOLT, FLANGE, 6X12	1
		14	95701-08030-07	BOLT, FLANGE 8X30	2
		15	96001-06012-07	BOLT, FLANGE, SH., 6 X 12	1
		16	96001-06014-00	BOLT, FLANGE, SH. 6 X 14	2
		17	96211-06000	BALL, STEEL, 6 MM	16

## F-6

### FRONT FENDER

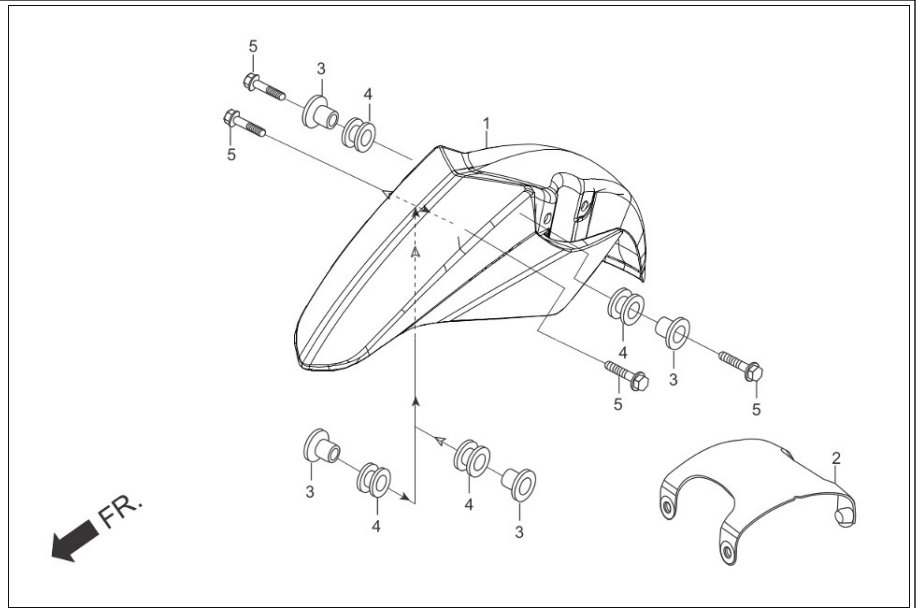

<b>Service Item</b>	<b>F.R.T.</b>
* FENDER, FRONT	0.1

**Group Number:** F-6 Model :: Karizma ZMR (May, 2014)

Ref No.	Part Number	Description	Req.
1	61100-AAR-000R	FENDER FRONT(PBM,NH-B08M)	1
	61100-AAR-000S	FENDER FRONT(PFW,NH-341P)	1
	61100-AAR-000T	FENDER FRONT(CBR,R-195C)	1
	61100-AAR-000U	FENDER FRONT(VOR,YR-250)	1
2	61102-KRY-970	STAY, FR. FENDER	1
3	61103-KRY-900	COLLAR, A FR.FENDER	4
4	61105-KTC-900	RUBBER, FRONT FENDER MOUNTING	4
5	95801-06032-00	BOLT, FLANGE, 6 X 32	4

**F-7**  
FRONT FORK

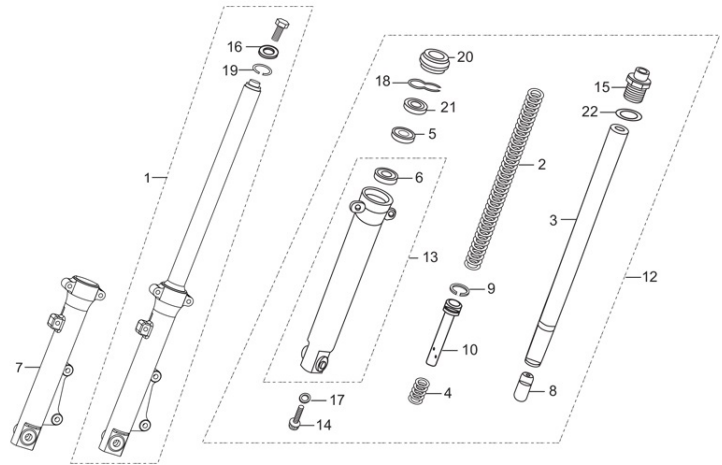

<b>Service Item</b>	<b>F.R.T.</b>	<b>Group Number: F-7 Model :: Karizma ZMR (May, 2014)</b>			
		<b>Ref No.</b>	<b>Part Number</b>	<b>Description</b>	<b>Req.</b>
FORK ASSY., FR. (ADD 0.2 FOR EACH)	0.5 --	1	51400-KRY-971	FORK ASSY,R	1
SPRING, FR. FORK (ADD 0.5 FOR EACH)	0.2 --	2	51401-KRY-971	SPRING FR. FORK	2
SEAL SET, FRONT FORK (ADD 0.5 FOR EACH)	-- --	3	51410-KRY-971	PIPE COMP. FR FORK	2
CASE COMP., R/L BOTTOM (ADD 0.6 FOR EACH)	0.9 --	4	51412-KSP-901	SPRING, REBOUND	2
		5	51412-KFN-851	SPRING, BACK UP	2
		6	51414-KK4-003	BUSH, GUIDE	2
		7	51420-KRY-971	CASE COMP. R FR. BOTTOM	1
		8	51432-KFN-851	PIECE, OIL LOCK	2
		9	51437-KVN-901	RING, PISTON	2
		10	51440-KFN-851	PIPE, SEAT	2
		12	51500-KRY-971	FORK ASSY,L	1
		13	51520-KRY-971	CASE COMP. L FR. BOTTOM	1
		14	90116-KAG-900	BOLT, SOCKET, 8 MM	2
		15	90123-KSP-871	BOLT A FRONT FORK	2
		16	90521-292-000	WASHER, PLAIN, 10.3 MM	2
		17	90544-KFN-851	WASHER, SPECIAL, 8MM	2
		18	90601-KFN-851	RING, OIL SEAL STOP	2
		19	90651-KRY-970	SNAP RING 31	2
		20	91254-GAA-003R	SEAL, DUST	2
		21	91255-GAA-003R	SEAL, OIL	2
		22	91356-KAG-900	O - RING	2

**F-8**  
CALIPER ASSY. R FR

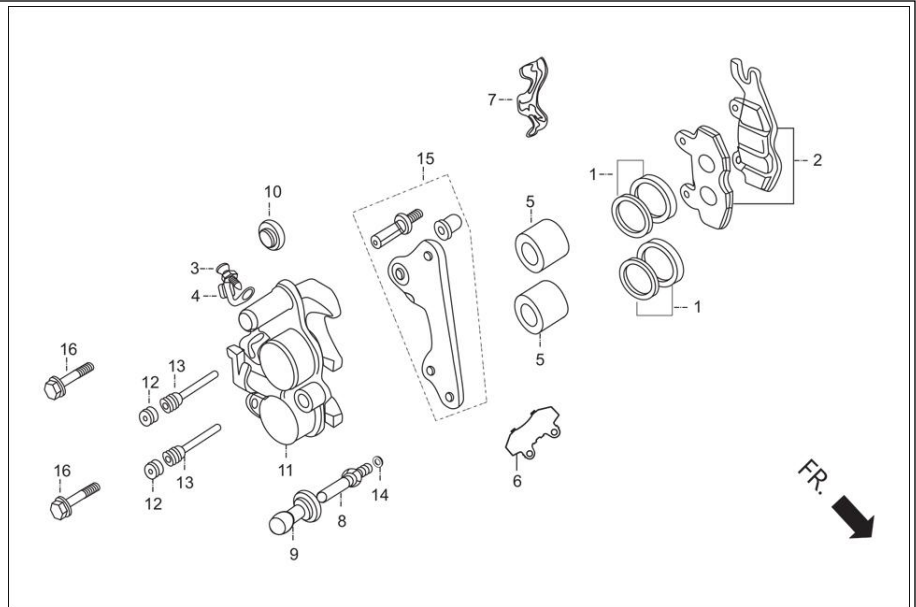

<b>Service Item</b>	<b>F.R.T.</b>	<b>Group Number: F-8 Model :: Karizma ZMR (May, 2014)</b>			
		<b>Ref No.</b>	<b>Part Number</b>	<b>Description</b>	<b>Req.</b>
PAD, SET FRONT	0.2	1	06451-GE2-405L	SEAL SET PISTON	2
BRACKET, RIGHT	--	2	06455-GCR-016L	PAD SET FRONT	1
PISTON	0.5	3	43352-568-003L	SCREW BLEEDER	1
(ADD 0.1 FOR EACH )	--	4	43353-461-771L	CAP BLEEDER	1
(INC. RELATIVE PART)	--	5	45107-MN5-006L	PISTON	2
CALIPER ASSY., R FR	0.4	6	43114-KW6-842L	SHIM B	1
		7	45108-ML4-006L	PAD SPRING	1
		8	45131-GE2-006L	PIN BOLT A	1
		9	45132-166-016L	BUSH BOOT PIN	1
		10	45133-MA3-006L	BOOT B	1
		11	45201-GT4-691L	BODY CALIPER FR.	1
		12	45203-MG3-016L	PLUG PIN	2
		13	45215-KA3-732L	PIN HANGER	2
		14	45216-166-006L	WASHER WAVE	1
		15	45290-KGB-611L	BRKT.SUB ASSY.R FR.CALIPER	1
		16	90155-KY4-900	BOLT, FLANGE, 8 X 25	2

**F-9**  
FRONT WHEEL

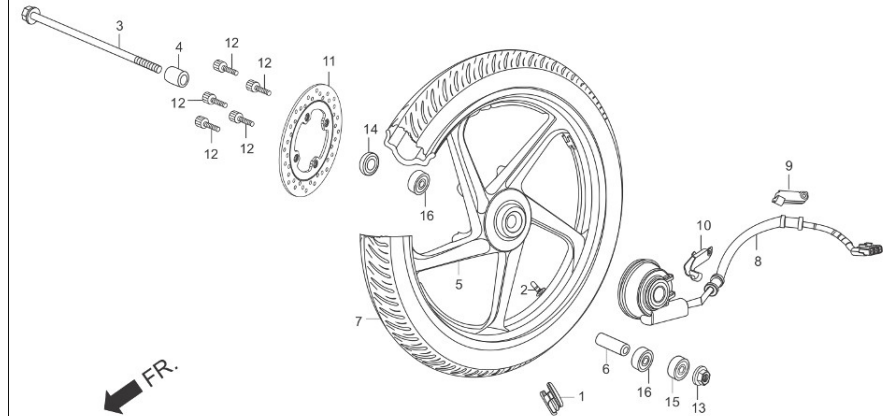



<b>Service Item</b>	<b>F.R.T.</b>	<b>Group Number: F-9 Model :: Karizma ZMR (May, 2014)</b>			
		<b>Ref No.</b>	<b>Part Number</b>	<b>Description</b>	<b>Req.</b>
* AXLE, FR. WHEEL	0.3	1	42704-MER-D00	WEIGHT, BALANCE 10	1
* GEAR BOX ASSY., SPDMT	--		42705-MER-D00	WEIGHT, BALANCE 20	1
* TUBE, TYRE	0.9		42706-MB0-000	WEIGHT, BALANCE 30	1
* TYRE, FR.	--				
* COLLAR, FR. AXLE DISTANCE	0.4	2	42753-KWF-90099	RIM VALVE	1
* DISC, FR. BRAKE	--	3	44301-KPL-900	AXLE, FRONT WHEEL	1
* BEARING, RADIAL BALL	--	4	44311-KRY-900	COLLAR, FR.WHEEL SIDE	1
(ADD 0.1 FOR EACH )	--	5	44601-AAR-H71	WHEEL COMP FR	1
* WHEEL FRONT	--	6	44620-400-000	COLLAR, FRONT DISTANCE	1
		7	44711-KRY-971	TYRE,FR	1
		8	44800-KRY-971	SENSOR ASSY,SPEED	1
		9	45163-KRY-970	STAY,SENSOR CORD	1
		10	45164-KRY-970	CLAMPER SP, SENSOR	1
		11	45251-KRY-981	DISC, FRONT BRAKE	1
		12	90105-KL8-741	BOLT, FR.DISK, 8 X 24	5
		13	90306-KST-942	NUT, CASTLE, 12 MM	1
		14	91251-KPH-901	DUST SEAL, 21 X 37 X 7	1
		15	91251-KPH-901	DUST SEAL, 21 X 37 X 7	1
		16	96150-63010-10	BEARING, BALL RADIAL, 6301 (UU)	2

**F-10**  
REAR BRAKE MASTER CYL.

FR.

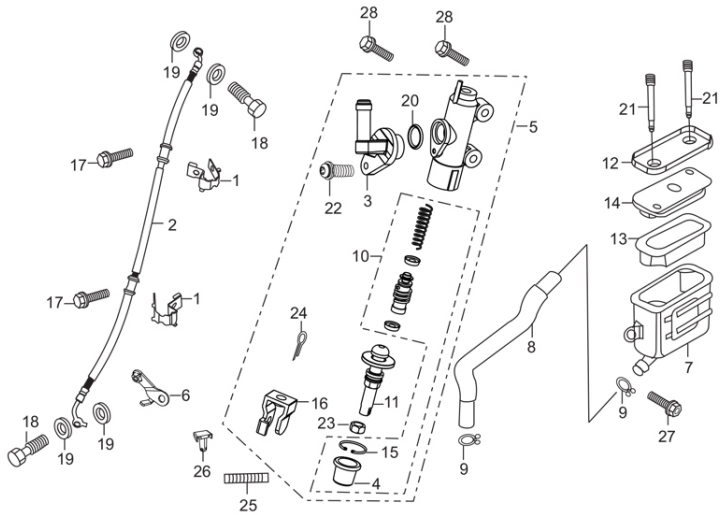

Service Item	F.R.T.
REAR BRAKE MASTER CYL.	0.1
DIAPHRAGM	--
HOSE COMP. , REAR BRAKE	0.4
CYL. SUB ASSY. REAR BRAKE MASTER	--
CYLINDER SET MASTER	--

Group Number: F-10 Model :: Karizma ZMR (May, 2014)				
Ref No.	Part Number	Description	Req.	
1	43155-KRY-970	CLAMPER RR BRAKE HOSE	2	
2	43310-AAR-000	HOSE COMP RR BRAKE	1	
3	43503-MEE-006	CONNECTOR	1	
4	43504-MB2-006	BOOT COMP.	1	
5	43510-KRY-971	M/C SUB ASSY REAR	1	
6	43102-AAR-000	STAY BRAKE HOSE	1	
7	43511-KW7-881	OIL CUP COMP.	1	
8	43512-KRY-971	HOSE COMP RR M/C	1	
9	43514-KS6-701	CLAMP. M/C OIL HOSE	2	
10	43520-MJ6-315	PISTON SET M/C	1	
11	43530-MV9-006	PUSH ROD COMP.	1	
12	45513-GW0-911	CAP M/C	1	
13	45520-GW0-911	DIAPHRAGM	1	
14	45521-GW0-911	PLATE DIAPHRAGM	1	
15	46182-MEL-D21	CIRCLIP	1	
16	46504-KV6-702	JOINT BRK ROD	1	
17	90103-MCS-G00	BOLT, FLANGE SH.6X12	2	
18	90145-MS9-610	OIL BOLT, 10 X 22	2	
19	90545-300-000	WASHER ,OIL BOLT	4	
20	91212-422-006	O RING	1	
21	93600-04045-1G	SCREW FLAT 4X45	2	
22	93893-04012-17L	SCREW WASHER 4X12	1	
23	94002-08000-0S	NUT HEX.8 MM	1	
24	94201-20150	PIN, SPLIT, 2.0 X 15	1	
25	94305-20102	PIN SPRING 2X10	1	
26	95015-54000	PIN D JOINT	1	
27	95701-06012-00	BOLT, FLANGE, 6X12	1	
28	95701-06022-08	BOLT FLANGE, 6 X 22	2	

**F-10A**  
CALIPER ASSY. REAR

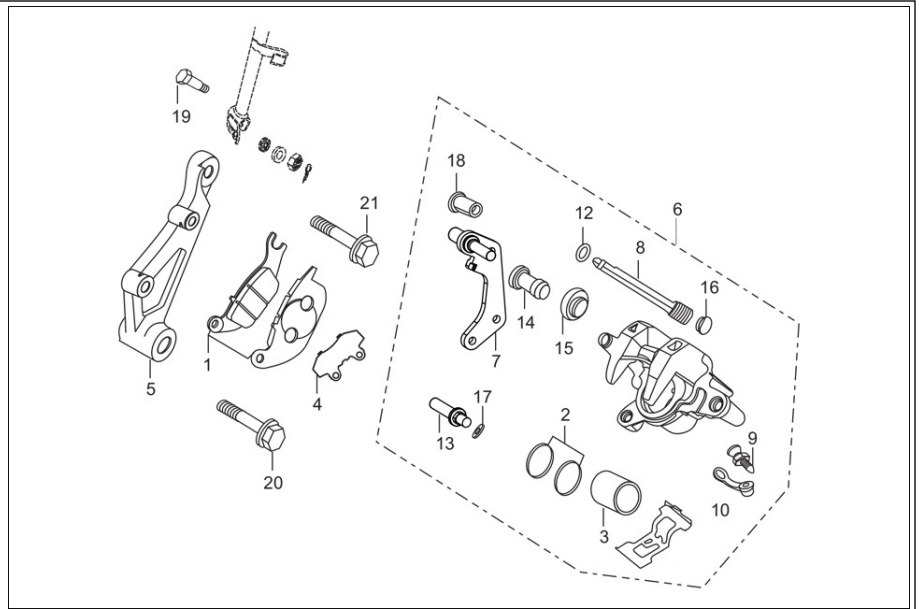

<b>Service Item</b>	<b>F.R.T.</b>	<b>Group Number: F-10A Model :: Karizma ZMR (May, 2014)</b>			
		<b>Ref No.</b>	<b>Part Number</b>	<b>Description</b>	<b>Req.</b>
PAD, SET FRONT	0.2	1	06435-KRY-971	PAD SET, RR.	1
BRACKET, RIGHT	--	2	06451-MA7-405	SEAL SET, PISTON	1
PISTON	0.5	3	43107-MA7-006	PISTON	1
(INC. RELATIVE PART)	--	4	43114-KW6-842L	SHIM B	1
(ADD 0.1 FOR EACH )	--	5	43115-AAR-000	HOLDER RR CALIPER	1
CALIPER ASSY., R FR	0.4	6	43150-KRY-972	CALIPER SUB ASSY. RR	1
		7	43190-KRY-971	BRKT SUB ASSY, RR.	1
		8	43215-KGH-901	PIN,HANGER	2
		9	43352-568-003L	SCREW BLEEDER	1
		10	43353-461-771L	CAP BLEEDER	1
		12	45111-MAJ-G41	STOPPER RING	1
		13	45131-GE2-006L	PIN BOLT A	1
		14	45132-166-016L	BUSH BOOT PIN	1
		15	45133-MA3-006L	BOOT B	1
		16	45203-MCC-006	PLUG,PIN	1
		17	45216-166-006L	WASHER WAVE	1
		18	45216-KPP-861	TORQUE NUT	1
		19	90127-KRY-970	BOLT TORQUE LINK	1
		20	90155-KY4-900	BOLT, FLANGE, 8 X 25	1
		21	90155-AAR-000	BOLT FLANGE 8X28	1

**F-11**  
REAR WHEEL

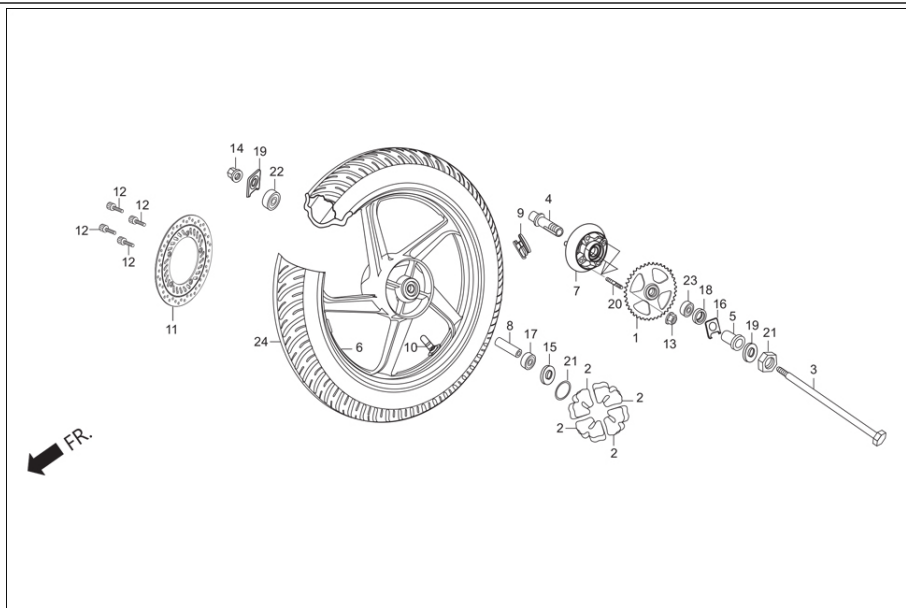

<b>Service Item</b>	<b>F.R.T.</b>	<b>Group Number: F-11 Model :: Karizma ZMR (May, 2014)</b>			
		<b>Ref No.</b>	<b>Part Number</b>	<b>Description</b>	<b>Req.</b>
* SPROCKET FINAL DRIVEN	0.5	1	41201-AAR-000	SPROCKET FINAL DRIVEN 40T	1
* DAMPER, RR. WHEEL (ONE OR ALL)	0.4 --	2	41241-KSP-900	DAMPER, RR WHEEL	4
* AXLE, RR. WHEEL	0.3	3	42301-AAR-000	AXLE REAR WHEEL	1
* SLEEVE, RR. AXLE	0.5	4	42303-KRY-931	SLEEVE, REAR WHEEL	1
* WHEEL COMP., REAR	--	5	42311-KRY-930	COLLAR, RR WHEEL SIDE	1
* FLANGE, FINAL DRIVEN	0.8	6	42601-AAR-000	WHEEL RR	1
* BEARING, BALL RADIAL (ADD 0.1 FOR EACH )	-- --	7	42611-KRY-930	FLANGE, FINAL DRIVEN(NH-35M)	1
* TYRE, REAR	--	8	42620-AAR-000	COLLAR RR AXLE DISTANCE	1
		9	42704-MER-D00	WEIGHT, BALANCE 10	1
			42705-MER-D00	WEIGHT, BALANCE 20	1
			42706-MB0-000	WEIGHT, BALANCE 30	1
		10	42753-KWF-90099	RIM VALVE	1
		11	43251-KRY-981	DISK, REAR BRAKE	1
		12	90105-KL8-741	BOLT, FR.DISK, 8 X 24	4
		13	90304-KCS-920	NUT U 10 MM	4
		14	90305-KVN-900	NUT, FLG. PT. 14 MM	1
		15	90559-KRY-970	WASHER, L RR AXLE	1
		16	90560-KRY-970	WASHER, R RR AXLE	1
		17	91253-KSP-901	DUST SEAL, 30 X 47 X 8	1
		18	91257-230-003	OIL SEAL 28X42X7	1
		19	91352-KSP-900	O RING, 51 X 2	1
		20	92915-10025-0E	BOLT, STUD II, 10X25	4
		21	95020-15100	NUT `E STEM	1
		22	96140-63020-10	BRG., BALL RADIAL, 6302 (U)	1
		23	96150-60050-10	BEARING, BALL RADIAL, 6005	1
		24	42711-AAR-000	TYRE REAR	1

**F-12**  
SEAT ASSY. / COWL REAR

FR.

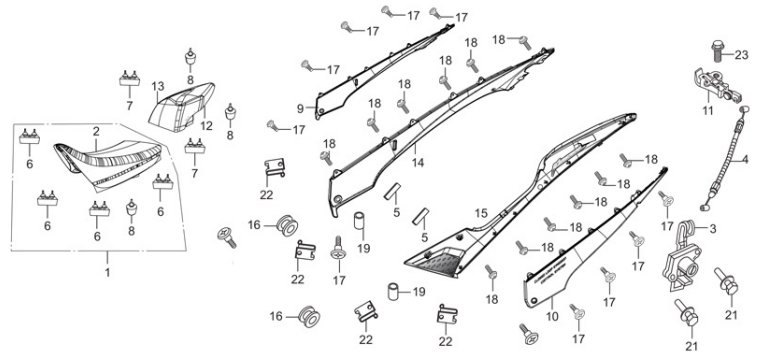



<b>Service Item</b>	<b>F.R.T.</b>	<b>Group Number: F-12 Model :: Karizma ZMR (May, 2014)</b>			
		<b>Ref No.</b>	<b>Part Number</b>	<b>Description</b>	<b>Req.</b>
LOCK ASSY., SEAT	0.5	1	77100-AAR-000	SEAT PAN RIDER	1
CABLE, SEAT LOCK	0.2	2	7710A-AAR-000	COVER,SEAT PAN RIDER	1
SEAT COMP., DOUBLE	0.1	3	77110-ML7-922	LOCK ASSY., SEAT	1
SET, R/L RR. COWL	0.2	4	77156-AAR-000	CABLE ASSY SEAT LATCH	1
(ADD 0.1 FOR EACH )	--	5	17506-AAR-000	BODY FILM PROTECTOR	2
SET, CENTER RR. COWL	0.2	6	77204-AAR-000	CUSHION RUBBER RIDER SEAT	4
		7	77205-AAR-000	CUSHION RUBBER PILLION SEAT FWD	2
		8	77206-AAR-000	CUSHION RUBBER PILLION SEAT REAR	2
		9	77217-AAR-000	SET, R TL S/BWK SIDE	1
		10	77218-AAR-000	SET, L TL S/BWK SIDE	1
		11	77220-KY6-000	HOOK, SEAT CATCH	1
		12	77300-AAR-000	SEAT PASSENGER COMP	1
		13	7730A-AAR-000	COVER,PAN SEAT PASSENGER	1
		14	77234-AAR-000R	SET, R TAIL SEC BWK(PBM,NH-B08M)	1
			77234-AAR-000S	SET, R TAIL SEC BWK(PFW,NH-341P)	1
			77234-AAR-000T	SET, R TAIL SEC BWK(CBR,R-195C)	1
			77234-AAR-000U	SET, R TAIL SEC BWK(VOR,YR-250)	1
		15	77244-AAR-000R	SET, L TAIL SEC BWK(PBM,NH-B08M)	1
			77244-AAR-000S	SET, L TAIL SEC BWK(PFW,NH-341P)	1
			77244-AAR-000T	SET, L TAIL SEC BWK(CBR,R-195C)	1
			77244-AAR-000U	SET, L TAIL SEC BWK(VOR,YR-250)	1
		16	83545-KCJ-690	RUBBER, SIDE COVER	2
		17	90105-KRY-970	SCREW,FAIRING A (5X11.5)	9
		18	93903-25210	SCREW, TAPPING, 5X12	12
		19	19052-KV0-000	COLLAR, RADIATOR MTG	2
		21	90107-GZ4-670	BOLT, BREAK OFF	2
		22	90320-GC3-000	NUT, SPRING, M5	4
		23	95701-06012-00	BOLT, FLANGE, 6X12	1

# F-13 FUEL TANK

← FR.

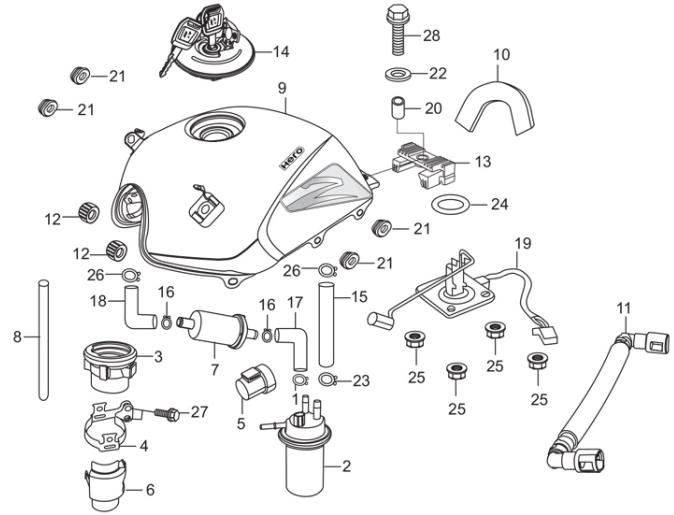

<b>Service Item</b>	<b>F.R.T.</b>	<b>Group Number: F-13 Model :: Karizma ZMR (May, 2014)</b>			
		<b>Ref No.</b>	<b>Part Number</b>	<b>Description</b>	<b>Req.</b>
* TANK SET., FUEL	--	1	16163-GHB-610	CLIP TUBE 65	1
* UNIT ASSY., FUEL	--	2	16700-AAR-001	UNIT ASSY FUEL PUMP	1
		3	16711-KRY-970	RUBBER, FUEL PUMP SHOCK	1
		4	16712-KRY-970	STAY, FUEL PUMP	1
		5	16713-KRY-970	HOLDER,STRAINER	1
		6	16720-KRY-970H	COVER FUEL PUMP UNIT	1
		7	16910-AAR-H71	FILTER COMP. FUEL	1
		8	17199-KRY-970	TUBE DRAIN	1
		9	17500-AAR-000R	SET, FUEL TANK(PBM,NH-B08M)	1
			17500-AAR-000S	SET, FUEL TANK(PFW,NH-341P)	1
			17500-AAR-000T	SET, FUEL TANK(CBR,R-195C)	1
			17500-AAR-000U	SET, FUEL TANK(VOR,YR-250)	1
		10	17506-KRY-900	FILM, PROTECTOR FUEL TANK	1
		11	17570-AAR-001	HOSE COMP FUEL FEED	1
		12	17611-KRY-970	CUSHION , FRONT FUEL TANK	2
		13	17613-MV4-000	CUSHION, RR. FUEL TANK	1
		14	17620-KRY-971	CAP COMP,FUEL FILLER	1
		15	17681-KRY-970	TUBE, FUEL	1
		16	15772-KTN-900	CLIP BREATHER TUBE	2
		17	17682-KRY-970	TUBE, FUEL PUMP BREATHER	1
		18	17683-KRY-970	TUBE,FUEL FILLER	1
		19	37800-KRY-961	UNIT ASSY., FUEL	1
		20	80101-KFN-850	COLLAR, 8X12	1
		21	83551-300-000	GROMMET, AIR CLEANER CASE	4
		22	90534-MV4-000	WASHER ,8.5X28	1
		23	90601-KAF-003	CLIP, SW. COVER	2
		24	91305-MC7-000	O-RING, 39.5 X 5	1
		25	94050-06000	NUT, FLANGE, 6 MM	4

26	95002-02130	CLIP B 12.5 TUBE	2
27	95701-06016-00	BOLT, FLANGE, 6X16	1
28	95701-08025-08	BOLT, FLANGE, 8X25	1

# F-15

## AIR CLEANER

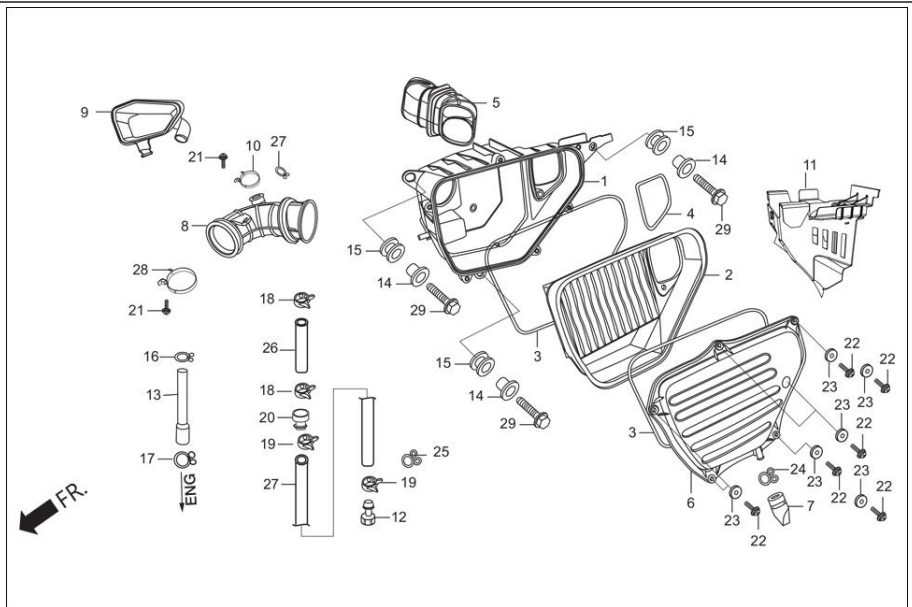

<b>Service Item</b>	<b>F.R.T.</b>
ELEMENT COMP., AIR CLEANER	0.1
CASE SUB ASSY.,AIR CLEANER	0.6
TUBE,AIR CLEANER CONN	0.5

<b>Group Number: F-15 Model :: Karizma ZMR (May, 2014)</b>				
<b>Ref No.</b>	<b>Part Number</b>	<b>Description</b>	<b>Req.</b>	
1	17210-KRY-970H	CASE COMP, AIR/C.	1	
2	17211-AAP-000	ELEMENT COMP, AIR/C	1	
3	17213-KRY-900	SEALA AIR CLEANER	2	
4	17214-KRY-900	SEAL B AIR CLEANER	1	
5	17219-KRY-970	DUCT, AIR/C	1	
6	17220-KRY-970H	COVER, AIR/C CASE	1	
7	17234-KS4-770	TUBE,AIR CLEANER DRAIN	1	
8	17253-KRY-970	TUBE, AIR/C CONN	1	
9	17311-KRY-970	RESONATOR	1	
10	17312-KFN-880	BAND, RESONATOR	1	
11	17324-AAR-000	COVER AIR DUCT	1	
12	17370-382-870	PLUG, BREATHER TUBE	1	
13	17371-KRY-900	TUBE, MISSION BREATHER	1	
14	19052-KV0-000	COLLAR, RADIATOR MTG	3	
15	83545-KCJ-690	RUBBER, SIDE COVER	3	
16	90601-KAF-003	CLIP, SW. COVER	1	
17	90651-MK3-780	CLIP, B 12.5 TUBE	1	
18	91405-KFN-850	CLAMP, D-17 TUBE	2	
19	91406-KFN-850	CLAMP, D14.5 TUBE	2	
20	91463-393-780	JOINT, TUBE	1	
21	93500-04025-0G	SCREW, PAN, 4X25	2	
22	93500-05016-0A	SCREW, PAN, 5 X 16	6	
23	94101-05000	WASHER , PLAIN, 5MM	6	
24	95002-02130	CLIP B 12.5 TUBE	1	
25	95002-80000	CLIP,C12 TUBE	1	
26	95003-37015-31	VINYL TUBE,11X15X150	1	
27	95005-12280-20	TUBE,12X280	1	
28	95018-50250	BAND 50 AIR/C CONN.TUBE	1	

29	95701-06020-00	BOLT, FLANGE, 6X20	3
----	----------------	--------------------	---

**F-16**  
EXHAUST MUFFLER

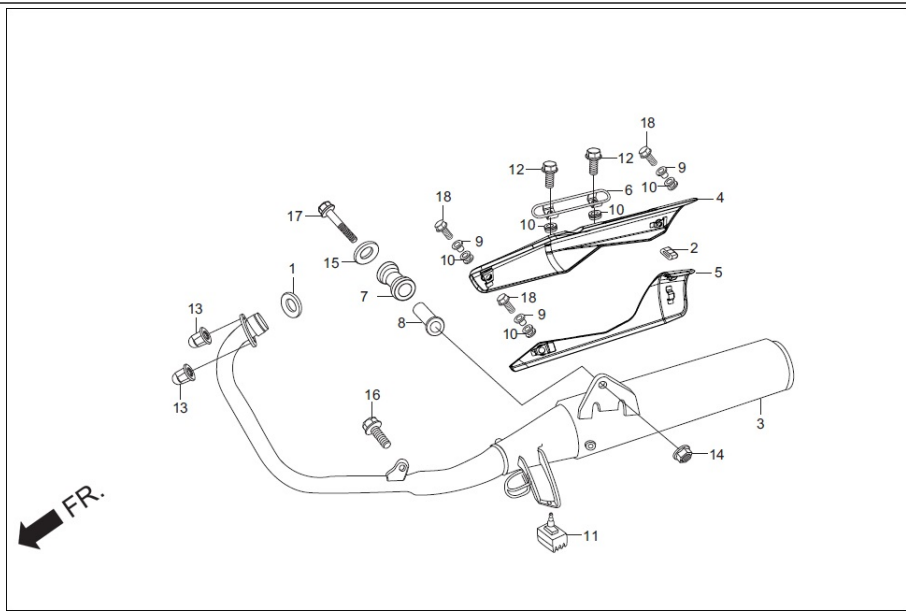



<b>Service Item</b>	<b>F.R.T.</b>	<b>Group Number: F-16 Model :: Karizma ZMR (May, 2014)</b>			
		<b>Ref No.</b>	<b>Part Number</b>	<b>Description</b>	<b>Req.</b>
* GASKET, EXH. PIPE	0.2	1	18291-KRY-930	GASKET, EXHAUST PIPE	1
* MUFFLER COMP., EXH	0.4	2	18293-KPK-900	RUBBER, PKG. PROTECTOR	1
		3	18300-AAR-000	MUFFLER COMP EXH	1
		4	18311-AAR-000	COVER MUFFLER UPPER	1
		5	18312-AAR-000	COVER MUFFLER LOWER	1
		6	18317-KRY-970	PROTECTOR, MUFF.	1
		7	18421-438-000	RUBBER, MUFFLER MOUNT	1
		8	18442-KRC-900	COLLAR, MUFFLER MOUNT	1
		9	33619-459-840A	COLLAR,WINKER STAY	3
		10	18345-MBT-610	RUBBER, PROTECTOR, MOUNT	5
		11	50505-KCC-900	STOPPER RUBBER, A STAND	1
		12	96001-06016-02	BOLT, FLANGE, SH. 6 X 16	2
		13	90305-KSP-900	NUT, 8MM EXP.	2
		14	94050-10000	NUT, FLANGE, 10MM	1
		15	94103-10000	WASHER, PLAIN, 10MM	1
		16	95701-10020-00	BOLT, FLANGE, 10X20	1
		17	95801-10055-00	BOLT, FLANGE, 10X55	1
		18	96001-06012-02	BOLT FLANGE 6X12	3

**F-17**  
STEP PILLION

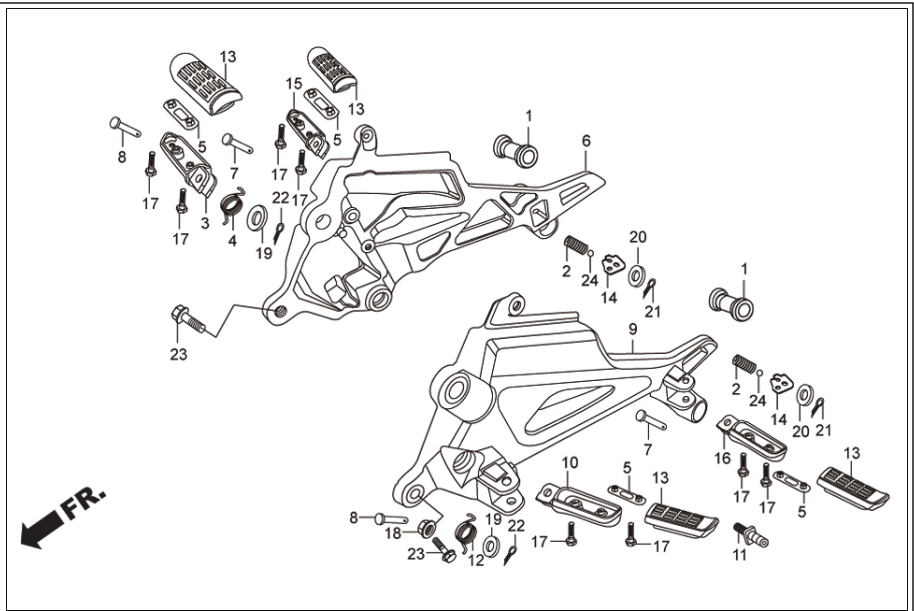

<b>Service Item</b>	<b>F.R.T.</b>	<b>Group Number: F-17 Model :: Karizma ZMR (May, 2014)</b>			
		<b>Ref No.</b>	<b>Part Number</b>	<b>Description</b>	<b>Req.</b>
* HOLDER, 'R' STEP	0.2	1	18421-438-000	RUBBER, MUFFLER MOUNT	2
* HOLDER, 'L' STEP	0.2	2	28333-300-000	SPRING KICK STARTER STOPPER	2
*BAR COMP,'R'MAIN STEP (INC. RELATIVE PART)	0.1 --	3	50612-KRY-970	ARM, R. STEP	1
*BAR COMP,'L' MAIN STEP (INC. RELATIVE PART)	0.1 --	4	50617-445-840	SPG. R STEP RETURN	1
		5	50619-KRY-970	PLATE STEP SET	4
		6	50630-KRY-970	HOLDER, R STEP	1
		7	50638-KRY-970	PIN, STEP BAR PILLION	2
		8	50639-KRY-970	PIN, STEP BAR	2
		9	50640-KRY-970	HOLDER, L STEP	1
		10	50642-KRY-970	ARM, L. STEP	1
		11	50643-KRY-970	PIVOT,CHNG PEDAL	1
		12	50644-445-840	SPG. L STEP RETURN	1
		13	50661-KRY-970	RUBBER, STEP	4
		14	50718-KRY-970	PLATE, P STEP CLICK	2
		15	50720-KRY-970	ARM, R PILLION STEP	1
		16	50730-KRY-970	ARM, L PILLION STEP	1
		17	90115-MV9-000	BOLT, M. STEP RUB.SET	8
		18	94050-08000	NUT, FLANGE, 8MM	1
		19	94101-06000	WASHER, PLAIN, 6 MM	2
		20	94102-08000	WASHER, PLAIN, 8MM	2
		21	94201-16120	PIN, SPLIT, 1.6 X 12	2
		22	94201-20150	PIN, SPLIT, 2.0 X 15	2
		23	95701-10025-00	BOLT, FLANGE, 10 X 25	2
		24	96211-08000	BALL STEEL 8 MM	2

# F-18

## GEAR CHANGE PEDAL

FR.

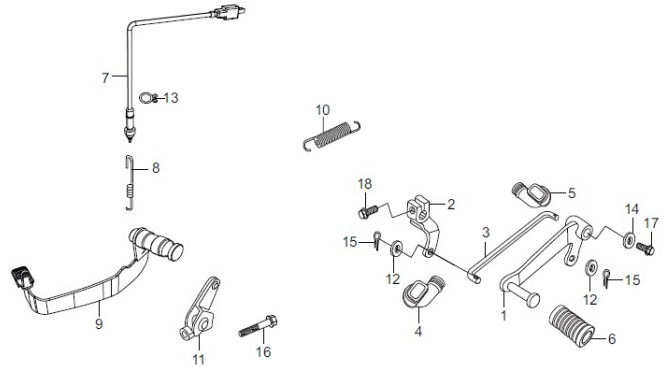

<b>Service Item</b>	<b>F.R.T.</b>	<b>Group Number: F-18 Model :: Karizma ZMR (May, 2014)</b>			
		<b>Ref No.</b>	<b>Part Number</b>	<b>Description</b>	<b>Req.</b>
* PEDAL ASSY., GEAR CHANGE	0.1	1	24701-KRY-970	PEDAL, GEAR CHANGE	1
* SWITCH ASSY., RR. STOP	0.2	2	24711-KRY-970	ARM, GEAR CHANGE	1
* PEDAL, BRAKE	0.5	3	24720-KRY-970	TIE ROD	1
		4	24721-GS3-000	COVER,CHANGE PEDAL	1
		5	24721-KRY-970	COVER,CHNG.PEDAL	1
		6	24781-KR3-770	RUBBER, CHANGE PEDAL	1
		7	35350-KFN-850	SW.ASSY.RR.STOP	1
		8	35357-KCT-690	SPRING STOP SWITCH	1
		9	46500-KRY-980	PEDAL, BRAKE	1
		10	46514-KN5-670	SPG. BRAKE PEDAL	1
		11	46515-KRY-970	ARM COMP, MIDDLE	1
		12	90502-155-000	WASHER,PLAIN,7MM	2
		13	90601-KAF-003	CLIP, SW. COVER	1
		14	94103-06000	WASHER PLAIN,6MM	1
		15	94201-20150	PIN, SPLIT, 2.0 X 15	2
		16	95801-08028-07	BOLT, FLANGE 8 X 28	1
		17	96001-06012-00	BOLT,FLANGE,SH.,6 X 12	1
		18	96001-06020-00	BOLT, FLANGE, SH. 6 X 20	1

## F-18A

### MAIN STAND / SIDE STAND

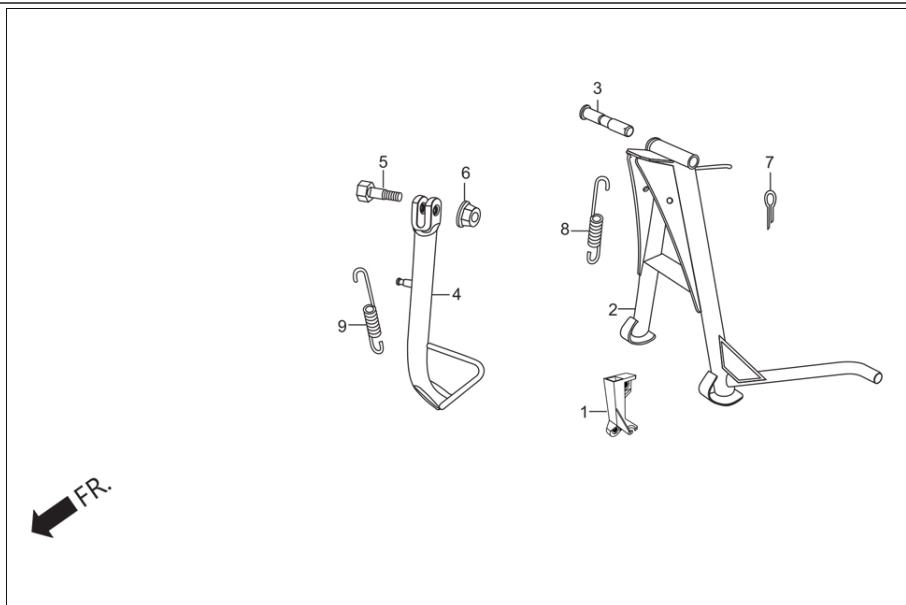

Service Item	F.R.T.
STAND COMP., MAIN	0.5
BAR COMP., SIDE STAND	0.2
SPRING G., MAIN STAND	--
SPRING, SIDE STAND	0.1

**Group Number:** F-18A **Model ::** Karizma ZMR (May, 2014)

Ref No.	Part Number	Description	Req.
1	35140-AAR-002	SIDE STAND SWITCH	1
2	50500-KRY-970	STAND COMP, MAIN	1
3	50526-KCT-690	SHAFT, MAIN STAND PIVOT	1
4	50530-KRY-970	BAR COMP.SIDE STAND	1
5	90107-GN1-010	SCREW SIDE STAND PIVOT	1
6	90304-KFN-850	NUT U 10 MM	1
7	94201-30300	PIN, SPLIT 3 X 30MM	1
8	95014-71702	SPRING G MAIN STAND	1
9	95014-72102	SPRING, SIDE STAND	1

**F-19**  
SWINGARM / CHAIN CASE

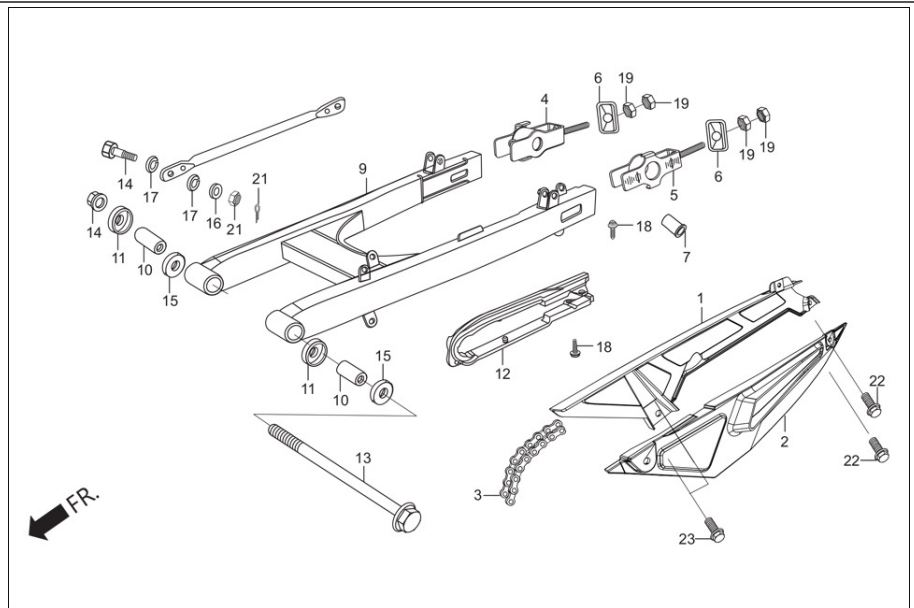

<b>Service Item</b>	<b>F.R.T.</b>	<b>Group Number: F-19 Model :: Karizma ZMR (May, 2014)</b>			
		<b>Ref No.</b>	<b>Part Number</b>	<b>Description</b>	<b>Req.</b>
CASE, DRIVE CHAIN	0.1	1	40510-AAR-000	CHAIN GUARD UPPER	1
CHAIN DRIVE	0.3	2	40520-AAR-000	LOWER BELT GUARD	1
SLIDER, CHAIN	--	3	40530-AAR-000	CHAIN DRIVE 520-108	1
ARM, REAR BRAKE STOPPER	0.2	4	40543-KRY-900	ADJUSTER, R CHAIN	1
BUSH, REAR FORK	1	5	40544-KRY-900	ADJUSTER, L CHAIN	1
(ONE OR ALL)	--	6	40546-KRY-900	CAP, REAR FORK END	2
COLLAR, SWING ARM PIVOT	0.6	7	42313-KRY-970	COLLAR RR. BRAKE SIDE	1
SWING ARM COMP., RR	0.8	9	52110-AAR-000	SWINGARM COMP RR	1
		10	52142-KRY-970	COLLAR PIVOT DIST.	2
		11	52144-GC4-005	DUST, SEAL CAP RR. SWINGRAM	2
		12	52170-AAR-000	SLIDER CHAIN	1
		13	90121-KBW-900	BOLT, SWING ARM (PIVOT)	1
		14	90305-KVN-900	NUT, FLG. PT. 14 MM	1
		15	90556-044-000	WASHER, FENDER SETTING	2
		16	90505-425-000	WASHER, 8 MM	1
		17	91254-KS6-003	DUST SEAL 20 X 26 X 4.5	2
		18	93901-25020	SCREW, TAPPING, 5X8	2
		19	94001-06000-0S	NUT, HEX., 6 MM	4
		20	94001-08000-0S	NUT, HEX., 8 MM	1
		21	94201-20150	PIN, SPLIT, 2.0 X 15	1
		22	95701-06012-00	BOLT, FLANGE, 6X12	4



## F-20 REAR CUSHION

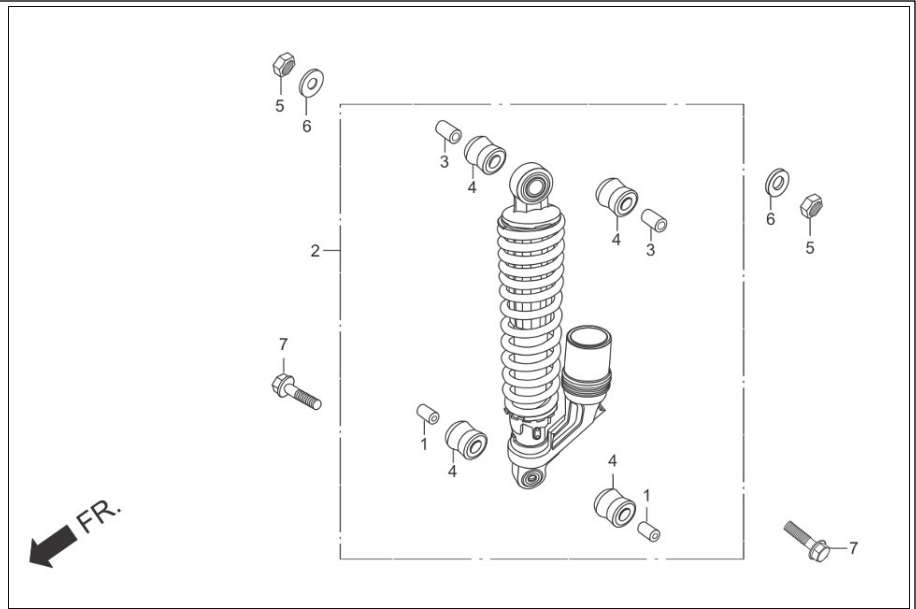

Service Item	F.R.T.
CUSHION ASSY., RR.	0.2
(ADD 0.1 FOR EACH )	--

**Group Number: F-20 Model :: Karizma ZMR (May, 2014)**

Ref No.	Part Number	Description	Req.
1	51488-KTN-701	COLLAR, RUBBER BUSH (UNDER)	2
2	52400-KRY-971	CUSHION ASSY,REAR	2
3	52486-KTN-701	COLLAR, RUBBER BUSH (UPPER)	2
4	52489-399-600	BUSH ,RUBBER (UPPER)	4
5	94001-12000-0S	NUT, HEX, 12 MM	2
6	94101-12800	WASHER,PLAIN ,12 MM	2
7	95801-10035-00	BOLT, FLANGE, 10X35	2

**F-21**  
REAR FENDER

FR.

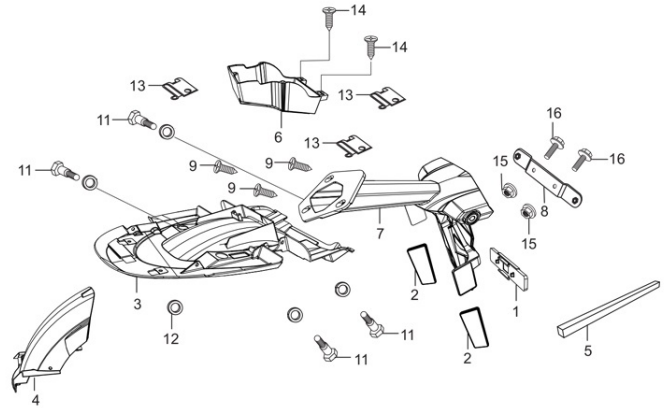

<b>Service Item</b>	<b>F.R.T.</b>	<b>Group Number: F-21 Model :: Karizma ZMR (May, 2014)</b>		
<b>Ref No.</b>	<b>Part Number</b>	<b>Description</b>	<b>Req.</b>	
FENDER COMP., REAR	0.4			
1	33742-AAR-001	REFLEX REFLECTOR REAR	1	
2	33743-AAR-001	REFLEX REFLECTOR SIDE	2	
3	80100-AAR-000	TRUNK PAN	1	
4	80250-AAR-000	FENDER REAR INNER (HUGGER)	1	
5	83403-AAR-000	SPONGE A	1	
6	83520-AAR-000	TOOL BOX	1	
7	84701-AAR-000	LICENSE PLATE BRACKET	1	
8	84701-KTC-900	BRACKET, RR. NO. PLATE	1	
9	90105-KRY-970	SCREW,FAIRING A (5X11.5)	3	
10	90111-187-000	BOLT, FLANGE. 6 MM	4	
11	90111-KW3-000	NUT COWL SET M5X0.8	4	
12	90116-ME9-000	BOLT,FLANGE, 6MM	1	
13	90320-GC3-000	NUT, SPRING, M5	3	
14	93903-25210	SCREW, TAPPING, 5X12	2	
15	94050-06000	NUT, FLANGE, 6 MM	2	
16	95701-06012-00	BOLT, FLANGE, 6X12	2	

**F-21A**  
REAR INNER FENDER(OPTIONAL)

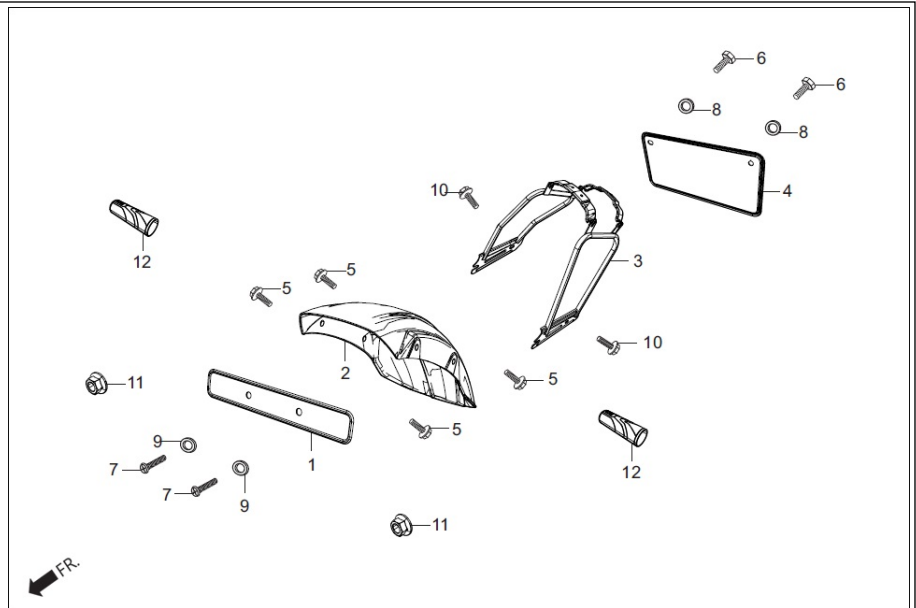

<b>Service Item</b>	<b>F.R.T.</b>	<b>Group Number: F-21A Model :: Karizma ZMR (May, 2014)</b>			
<b>* FENDER COMP., REAR</b>	<b>0.4</b>	<b>Ref No.</b>	<b>Part Number</b>	<b>Description</b>	<b>Req.</b>
		1	64310-198-D20A	PLATE, FRONT NUMBER	1
		2	80350-AAR-000	RR INNER FENDER EXTN	1
		3	80983-AAR-000	SUP. STR. ASSY RR INR. FENDER EXTN	1
		4	84701-P26-D00A	NUMBER, PLATE REAR	1
		5	90111-187-000	BOLT, FLANGE. 6 MM	4
		6	92000-06012-0A	BOLT,HEX.,6X12	2
		7	93500-05010-1G	SCREW PAN 5 X 10	2
		8	94101-06000	WASHER, PLAIN, 6 MM	2
		9	94101-05000	WASHER , PLAIN, 5MM	2
		10	95701-10014-00	BOLT FLANGE 10X14	2
		11	94050-05000	NUT FLANGE, 5 MM	2
		12	99620-AAM-201	GRIP COVER - PREMIUM (SET OF 2)	2

**F-22**  
**WINKERS**

← FR.

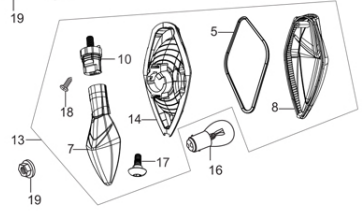
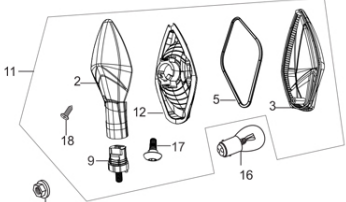
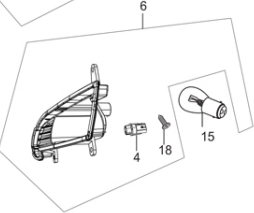
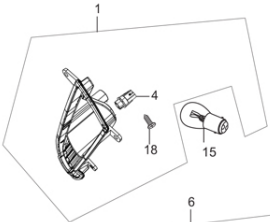

<b>Service Item</b>	<b>F.R.T.</b>	<b>Group Number: F-22 Model :: Karizma ZMR (May, 2014)</b>			
		<b>Ref No.</b>	<b>Part Number</b>	<b>Description</b>	<b>Req.</b>
WINKER ASSY. R/L FR. (ADD 0.1 FOR EACH )	--	1	3340B-AAR-001	WINKER ASSY R FR	1
STAY COMP., WINKER (ADD 0.1 FOR EACH )	--	2	33401-AAR-001	HOUSING R	1
LENS, WINKER R/L RR (ADD 0.1 FOR EACH )	--	3	33402-AAR-001	LENS R	1
BULB, WINKER R/L RR (ADD 0.1 FOR EACH )	--	4	33405-AAR-001	BULB HOLDER CP	2
BULB, WINKER	--	5	33408-AAR-001	PACKING	2
		6	3345B-AAR-001	WINKER ASSY L FR	1
		7	33451-AAR-001	HOUSING L	1
		8	33452-AAR-001	LENS L	1
		9	33941-AAR-001	STAY CP R	1
		10	33946-AAR-001	STAY CP L	1
		11	3360B-AAR-001	WINKER ASSY R RR	1
		12	33605-AAR-001	REFLECTOR COMP R	1
		13	3365B-AAR-001	WINKER ASSY L RR	1
		14	33655-AAR-001	REFLECTOR COMP L	1
		15	34908-AAB-401	BULB (12V10W) AMBER E MARK	2
		16	34930-AAC-700	BULB(12V 10W) AMBER	2
		17	90380-AAR-001	SCREW SPECIAL	2
		18	93903-25210	SCREW, TAPPING, 5X12	4
		19	94002-08080-0S	NUT HEX.8MM	2

## F-23 TAIL LIGHT

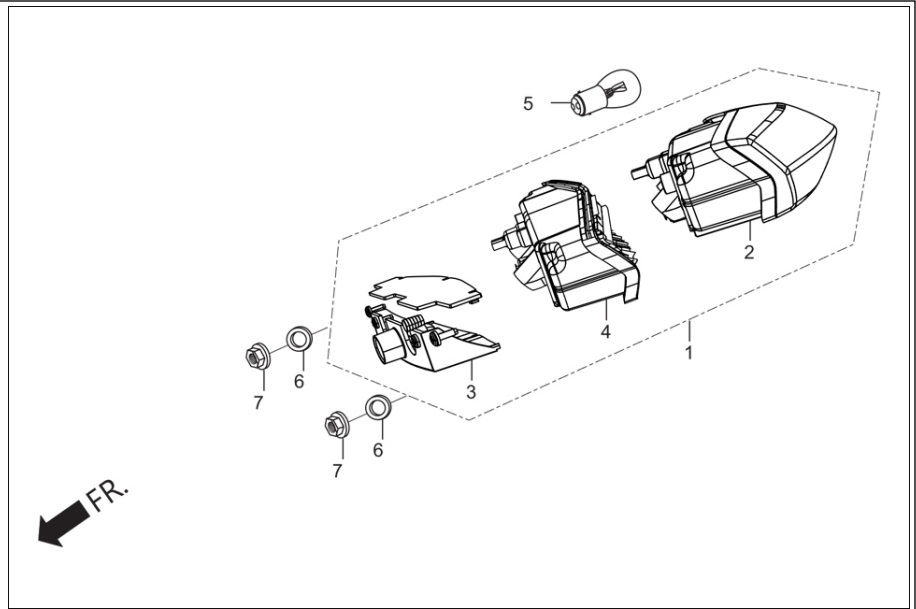

Service Item	F.R.T.
LIGHT ASSY.,TAIL	--
BASE COMP.,	--
LENS COMP.,	--
BULB, TAIL & STOP LIGHT	--
STAY, TAILLIGHT	--

**Group Number:** F-23 Model :: Karizma ZMR (May, 2014)

Ref No.	Part Number	Description	Req.
1	3370B-AAR-001	LIGHT ASSY REAR COMB	1
2	33703-AAR-001	LENS COMP TAIL LIGHT	1
3	33704-AAR-001	SOCKET COMP TAIL LIGHT	1
4	33720-AAR-001	LENS (NPL)	1
5	34351-AAR-001	BULB (W5W)	1
6	90563-355-000	WASHER, WHEEL, 6 MM	2
7	94050-06000	NUT, FLANGE, 6 MM	2



**F-24**  
WIRE HARNESS

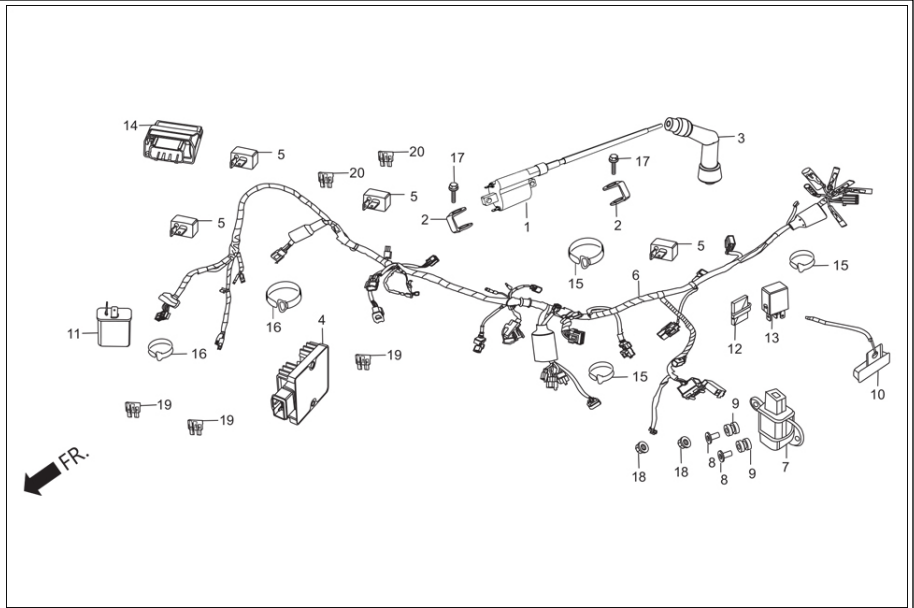

<b>Service Item</b>	<b>F.R.T.</b>	<b>Group Number: F-24 Model :: Karizma ZMR (May, 2014)</b>			
		<b>Ref No.</b>	<b>Part Number</b>	<b>Description</b>	<b>Req.</b>
UNIT COMP., DIGITAL DC-CDI	0.4	1	30510-AAR-001	COIL COMP IGN	1
COIL ASSY., CDI IGN.	--	2	30520-ML7-000	SPACER IGN. COIL	2
REG. RECT. ASSY	0.6	3	30700-KTC-A21	CAP ASSY., NOISE SUPPRESSOR	1
HARNESS, WIRE	1	4	31600-KVK-901	REG. RECT. ASSY	1
RELAY COMP., WINKER	--	5	31700-124-000	RECTIFIER ASSY., SILICON	4
		6	32100-AAR-000	HARNESS WIRE	1
		7	35161-GBJ-M30	SENSOR COMP, BANK ANGLE	1
		8	35162-MFA-D01	COLLAR	2
		9	35163-MBZ-C50	GROMMET	2
		10	35400-AAR-001	RESISTOR COMP	1
		11	38301-KWA-831	RELAY COMP., WINKER	1
		12	38306-GE7-000	SUSPENSION, WINKER RELAY	1
		13	38501-MCS-G00	RELAY COMP., POWER (MICRO ISO 4P)	1
		14	38770-AAR-001	UNIT COMP ECU	1
		15	90651-KV6-003	BAND WIRE	3
		16	91547-SF4-003	BAND,HARN	2
		17	92101-06020-4J	BOLT, HEX., 6 X 20	2
		18	94050-04000	NUT FLANGE 4 MM	2
		19	98200-30750	BLADE, FUSE, 7.5A	3
		20	98200-31500	BLADE, FUSE, 15A	2

# F-24A BATTERY ASSY

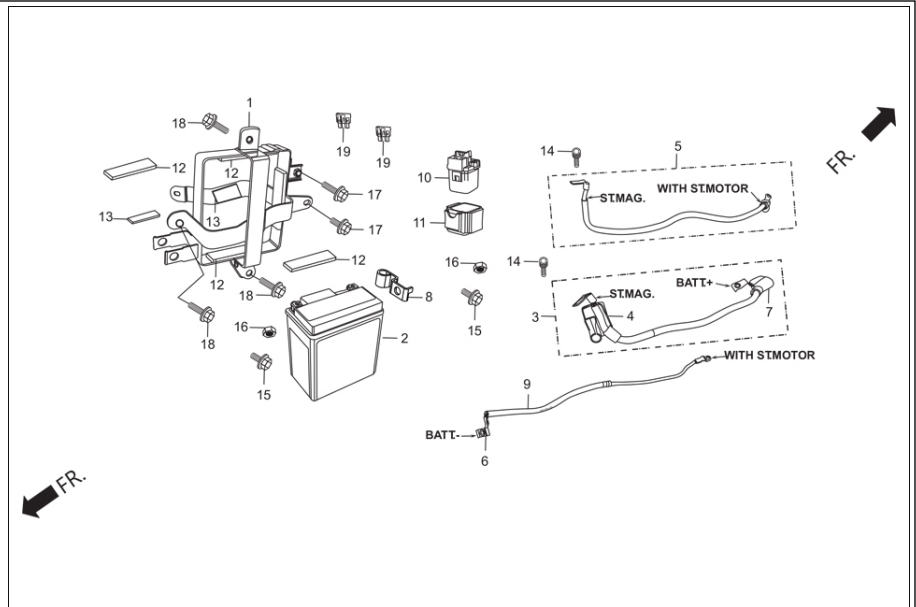

<b>Service Item</b>	<b>F.R.T.</b>	<b>Group Number: F-24A Model :: Karizma ZMR (May, 2014)</b>			
CASE COMP., BATTERY	--	<b>Ref No.</b>	<b>Part Number</b>	<b>Description</b>	<b>Req.</b>
BATTERY ASSY.	0.1	1	17232-KRY-970	CASE COMP BATTERY	1
		2	31500-KRY-801	BATTERY ASSY MF7	1
		3	32401-AAR-001	CABLE ST-MAG BATT	1
		4	32406-MT3-610	COVER, ST. MAG TERMINAL A	1
		5	32410-KRY-970	CABLE START MOTOR	1
		6	32413-KRY-970	TERMINAL, BAT CABLE	1
		7	32414-MW0-000	COVER, BATTERY TERMINAL	1
		8	32418-KRY-970	TERMINAL, BAT	1
		9	32601-KRY-971	CABLE BAT. EARTH	1
		10	35850-KR3-870	SWITCH ASSY., START MAG.	1
		11	35856-KBG-007	RUBBER,SHOCK	1
		12	50383-KRC-900	RUBBER , BATTERY	4
		13	83407-KCC-902	CUSHION, FR. VISOR	2
		14	90111-MR5-000	BOLT, SOCKET, 5X9	2
		15	90122-KVT-941	BOLT BATTERY TERMINAL	2
		16	90306-KVT-941	NUT BATTERY TERMINAL	2
		17	95701-06008-00	BOLT, FLANGE, 6X8	2
		18	95701-06012-00	BOLT, FLANGE, 6X12	3
		19	98200-32000	BLADE, FUSE, 20A	2

**F-25**  
FRAME BODY / GRIP REAR

FR.

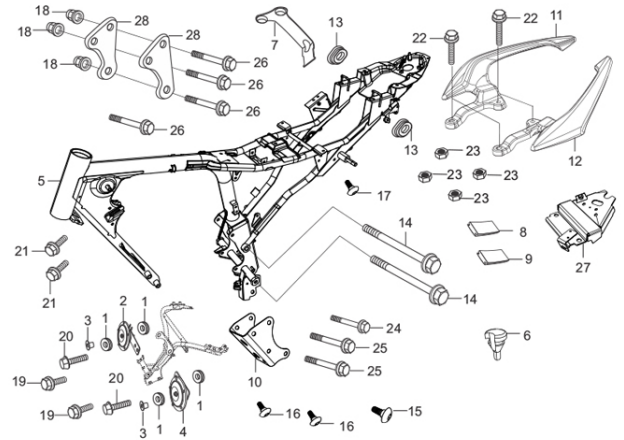

Service Item	F.R.T.
* BODY COMP., FRAME	*5.3
* PLATE, FR. ENGINE HANGER	0.2

Group Number: F-25 Model :: Karizma ZMR (May, 2014)			
Ref No.	Part Number	Description	Req.
1	33714-KL3-620	RUBBER, TAIL LIGHT	4
2	38110-KRY-971	HORN COMP.(HIGH)	1
3	38117-KFE-701	COLLAR, HORN SET	2
4	38120-AAR-000	HORN COMP.(LOW)	1
5	50100-AAR-000	FRAME BODY COMP	1
6	50137-AAR-000	PLUG CABLE RETENTION	1
7	50153-KRY-970	STAY FUEL FILTER	1
8	50197-KRY-900	RUBBER, STIFFNER A	1
9	50199-KRY-900	RUBBER, STIFFNER B	1
10	50351-KRY-960	PLATE, FR.ENG.HANGER	1
11	50400-AAR-000	GRIP REAR R	1
12	50450-AAR-000	GRIP REAR L	1
13	83551-300-000	GROMMET, AIR CLEANER CASE	2
14	90019-399-010	BOLT, FLANGE, 10 X 110	2
15	90103-AAR-000	SCREW SHOULDER,M6X1.0	1
16	90113-AAR-000	SCREW TRUSS 5X20	2
17	90380-AAR-001	SCREW SPECIAL	1
18	90443-107-000	NUT, CAP, 8 MM	3
19	95701-06012-00	BOLT, FLANGE, 6X12	2
20	95701-06020-07	BOLT, FLANGE, 6 X 20	2
21	95701-08016-00	BOLT, FLANGE, 8X16	2
22	95701-08025-00	BOLT, FLANGE 8 X 25	4
23	94050-08000	NUT, FLANGE, 8MM	4
24	95801-AAR-000	BOLT FLANGE 8X60	1
25	95802-AAR-000	BOLT FLANGE 8X65	2
26	95803-AAR-000	BOLT FLANGE 8X85	4
27	50161-AAR-000	REAR SEAT CABLE GUIDE	1
28	50353-KRY-970	PLATE ENG.UP.HANGER	2

## F-26 TOOLS

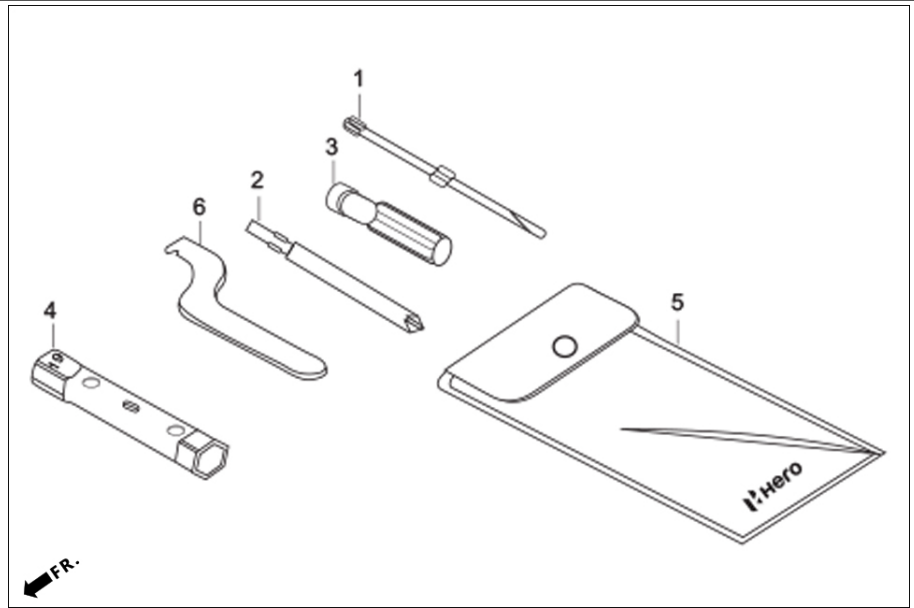

Service Item

F.R.T.

Group Number: F-26 Model :: Karizma ZMR (May, 2014)

Ref No.	Part Number	Description	Req.
1	89102-538-000	SCREW, DRIVER PLUS/MINUS	1
2	89102-AAC-000	NO.3 CROSS POINT SCREW DRIVER	1
3	89103-538-000	GRIP, SCREW DRIVER	1
4	89213-AAR-000	BOX WRENCH P18	1
5	89216-AAD-H00	TOOL BAG	1
6	99007-45000	PIN, SPANNER	1

**F-27**  
**STRIPE / MARKS**

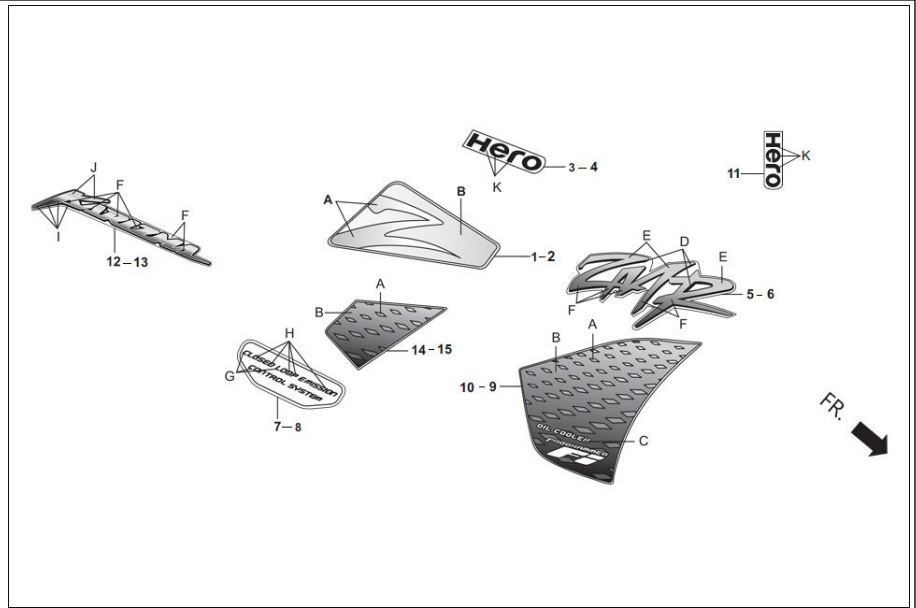

Service Item

F.R.T.

Group Number: F-27 Model :: Karizma ZMR (May, 2014)

Ref No.	Part Number	Description	Req.
1	17507-AAR-H80ZA	STRIPE R FUEL TANK(TYPE-1)	1
	17507-AAR-H80ZB	STRIPE R FUEL TANK(TYPE-2)	1
	17507-AAR-H80ZC	STRIPE R FUEL TANK(TYPE-3)	1
	17507-AAR-H80ZD	STRIPE R FUEL TANK(TYPE-4)	1



**SPECIFIED COLOUR CHART FOR STRIPE RIGHT, FUEL TANK**

SPECIFIED COLOUR TYPE	<b>A</b>	<b>B</b>	<b>MAIN BODY COLOUR</b>
1	RED	PANTHER BLACK METALLIC NH-B08M	PANTHER BLACK METALLIC (NH-B08M)
2	CANDY BLAZING RED	PEARL FADELESS WHITE (NH-341P)	PEARL FADELESS WHITE (NH-341P)
4	JELLY PINK METALLIC	R-195C CANDY BLAZING RED	CANDY BLAZING RED R-195C
3	ZINNIA YELLOW	VIBRANT ORANGE (YR-250)	VIBRANT ORANGE (YR-250)

**F-27**  
**STRIPE / MARKS**

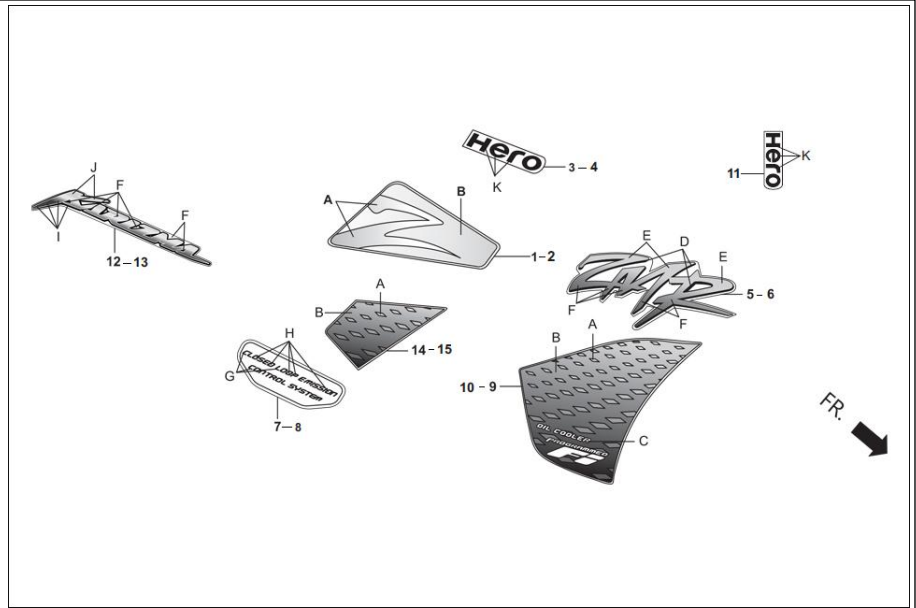

Service Item

F.R.T.

Group Number: F-27 Model :: Karizma ZMR (May, 2014)

Ref No.	Part Number	Description	Req.
2	17508-AAR-H80ZA	STRIPE L FUEL TANK(TYPE-1)	1
	17508-AAR-H80ZB	STRIPE L FUEL TANK(TYPE-2)	1
	17508-AAR-H80ZC	STRIPE L FUEL TANK(TYPE-3)	1
	17508-AAR-H80ZD	STRIPE L FUEL TANK(TYPE-4)	1

**SPECIFIED COLOUR CHART FOR STRIPE LEFT, FUEL TANK**

SPECIFIED COLOUR TYPE	<b>A</b>	<b>B</b>	<b>MAIN BODY COLOUR</b>
1	RED	PANTHER BLACK METALLIC NH-B08M	PANTHER BLACK METALLIC (NH-B08M)
2	CANDY BLAZING RED	PEARL FADELESS WHITE (NH-341P)	PEARL FADELESS WHITE (NH-341P)
4	JELLY PINK METALLIC	R-195C CANDY BLAZING RED	CANDY BLAZING RED R-195C
3	ZINNIA YELLOW	VIBRANT ORANGE (YR-250)	VIBRANT ORANGE (YR-250)

**F-27**  
**STRIPE / MARKS**

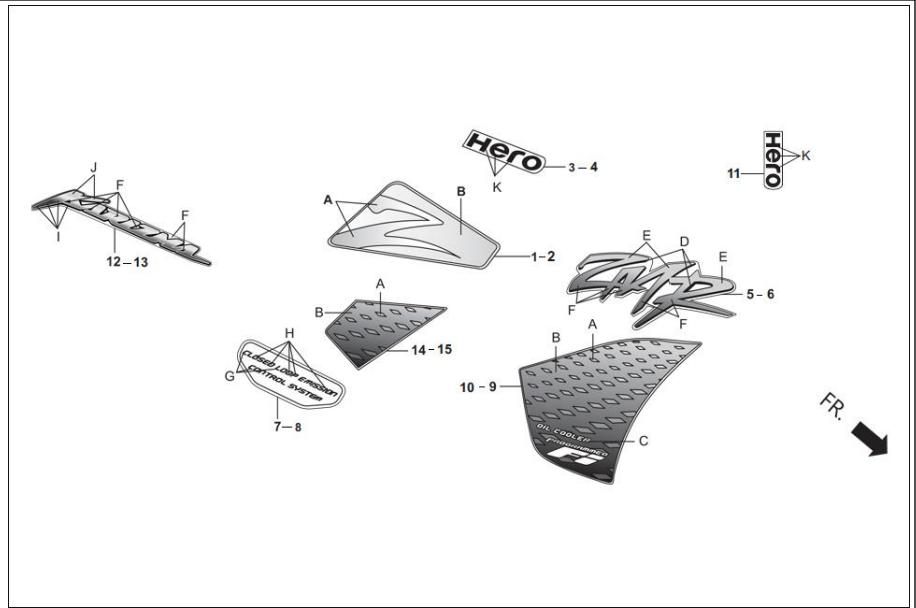

Service Item

F.R.T.

Group Number: F-27 Model :: Karizma ZMR (May, 2014)

Ref No.	Part Number	Description	Req.
3	17507-AAR-000R	MARK R FUEL TANK(TYPE-1)	1
	17507-AAR-000S	MARK R FUEL TANK(TYPE-2)	1

**SPECIFIED COLOUR CHART FOR MARK RIGHT, FUEL TANK**

SPECIFIED COLOUR TYPE	<b>K</b>	<b>MAIN BODY COLOUR</b>
1	PEARL FADELESS WHITE (NH-341P)	PANTHER BLACK METALLIC (NH-B08M)
		PEARL FADELESS WHITE (NH-341P)
2	NH-BLACK	CANDY BLAZING RED R-195C
		VIBRANT ORANGE (YR-250)

**F-27**  
**STRIPE / MARKS**

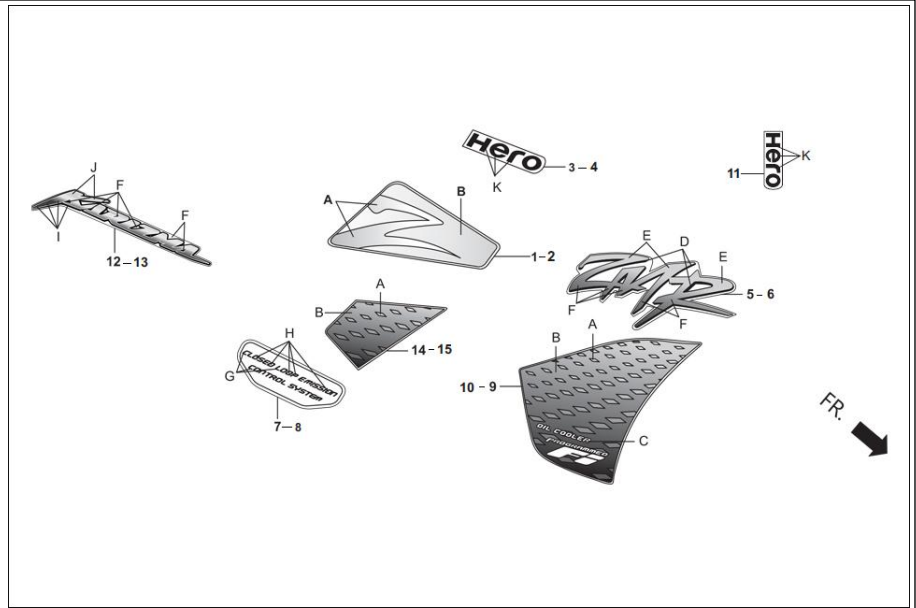

Service Item

F.R.T.

Group Number: F-27 Model :: Karizma ZMR (May, 2014)

Ref No.	Part Number	Description	Req.
4	17508-AAR-000R	MARK L FUEL TANK(TYPE-1)	1
	17508-AAR-000S	MARK R FUEL TANK(TYPE-2)	1

SPECIFIED COLOUR CHART FOR MARK LEFT, FUEL TANK		
SPECIFIED COLOUR TYPE	K	MAIN BODY COLOUR
1	PEARL FADELESS WHITE (NH-341P)	PANTHER BLACK METALLIC (NH-B08M)
		PEARL FADELESS WHITE (NH-341P)
2	NH-BLACK	CANDY BLAZING RED R-195C
		VIBRANT ORANGE (YR-250)

**F-27**  
**STRIPE / MARKS**

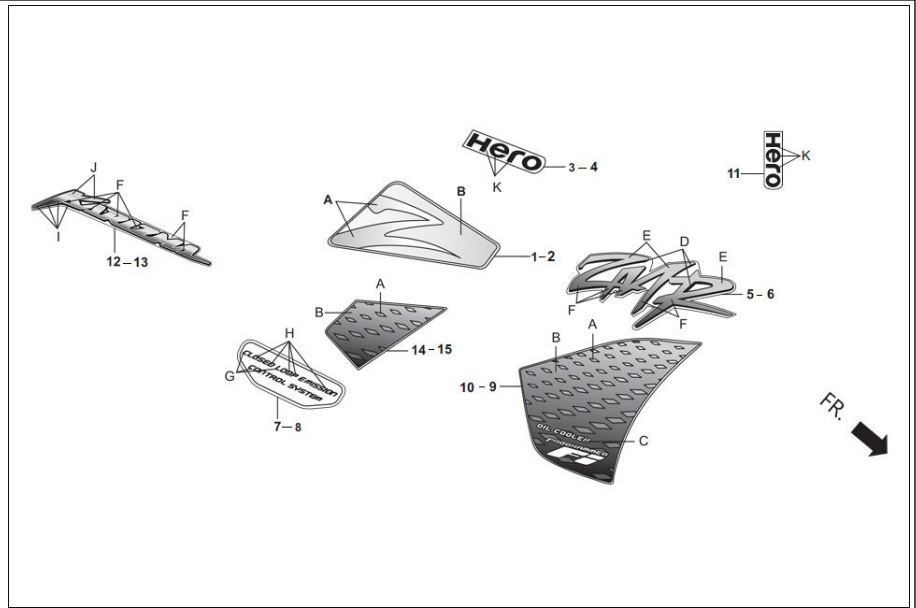

Service Item

F.R.T.

Group Number: F-27 Model :: Karizma ZMR (May, 2014)

Ref No.	Part Number	Description	Req.
5	64216-AAR-000R	STRIPE A R FAIRING SIDE(TYPE-1)	1
	64216-AAR-000S	STRIPE A R FAIRING SIDE(TYPE-2)	1
	64216-AAR-000T	STRIPE A R FAIRING SIDE(TYPE-3)	1
	64216-AAR-000U	STRIPE A R FAIRING SIDE(TYPE-4)	1



**SPECIFIED COLOUR CHART FOR STRIPE A, RIGHT, FAIRING SIDE**

<b>SPECIFIED COLOUR TYPE</b>	<b>D</b>	<b>E</b>	<b>F</b>	<b>G</b>	<b>MAIN BODY COLOUR</b>
1	NH-194M-U HEAVY GRAY ME.	FIGHTING RED	R-195C CANDY BLAZING RED	TRANSPARENT	PANTHER BLACK METALLIC (NH-B08M)
2	NH-1 BLACK	R-195C CANDY BLAZING RED	MAROON	TRANSPARENT	PEARL FADELESS WHITE (NH-341P)
3	NH-1 BLACK	JELLY PINK	R-195C CANDY BLAZING RED	TRANSPARENT	CANDY BLAZING RED R-195C
4	NH-1 BLACK	SPORTS RED	R-195C CANDY BLAZING RED	TRANSPARENT	VIBRANT ORANGE (YR-250)

# F-27 STRIPE / MARKS

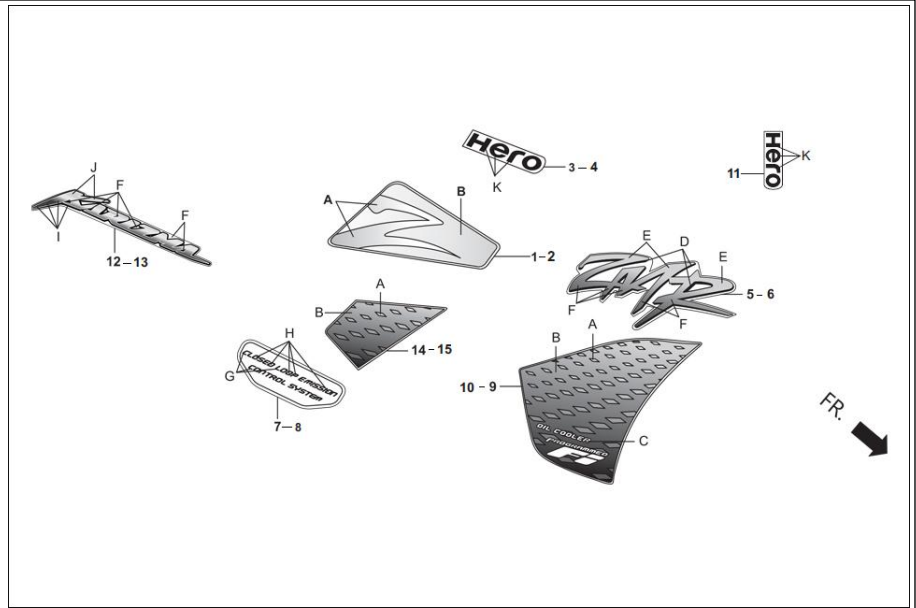

Service Item	F.R.T.	Group Number: F-27 Model :: Karizma ZMR (May, 2014)																					
		<table border="1" style="width: 100%; border-collapse: collapse;"> <thead> <tr> <th style="width: 10%;">Ref No.</th> <th style="width: 20%;">Part Number</th> <th style="width: 60%;">Description</th> <th style="width: 10%;">Req.</th> </tr> </thead> <tbody> <tr> <td>6</td> <td>64217-AAR-000R</td> <td>STRIPE A L FAIRING SIDE(TYPE-1)</td> <td>1</td> </tr> <tr> <td></td> <td>64217-AAR-000S</td> <td>STRIPE A L FAIRING SIDE(TYPE-2)</td> <td>1</td> </tr> <tr> <td></td> <td>64217-AAR-000T</td> <td>STRIPE A L FAIRING SIDE(TYPE-3)</td> <td>1</td> </tr> <tr> <td></td> <td>64217-AAR-000U</td> <td>STRIPE A L FAIRING SIDE(TYPE-4)</td> <td>1</td> </tr> </tbody> </table>	Ref No.	Part Number	Description	Req.	6	64217-AAR-000R	STRIPE A L FAIRING SIDE(TYPE-1)	1		64217-AAR-000S	STRIPE A L FAIRING SIDE(TYPE-2)	1		64217-AAR-000T	STRIPE A L FAIRING SIDE(TYPE-3)	1		64217-AAR-000U	STRIPE A L FAIRING SIDE(TYPE-4)	1	
Ref No.	Part Number	Description	Req.																				
6	64217-AAR-000R	STRIPE A L FAIRING SIDE(TYPE-1)	1																				
	64217-AAR-000S	STRIPE A L FAIRING SIDE(TYPE-2)	1																				
	64217-AAR-000T	STRIPE A L FAIRING SIDE(TYPE-3)	1																				
	64217-AAR-000U	STRIPE A L FAIRING SIDE(TYPE-4)	1																				

**SPECIFIED COLOUR CHART FOR STRIPE A, LEFT, FAIRING SIDE**

SPECIFIED COLOUR TYPE	<b>D</b>	<b>E</b>	<b>F</b>	<b>G</b>	<b>MAIN BODY COLOUR</b>
1	NH-194M-U HEAVY GRAY ME.	FIGHTING RED	R-195C CANDY BLAZING RED	TRANSPARENT	PANTHER BLACK METALLIC (NH-B08M)
2	NH-1 BLACK	R-195C CANDY BLAZING RED	MAROON	TRANSPARENT	PEARL FADELESS WHITE (NH-341P)
3	NH-1 BLACK	JELLY PINK	R-195C CANDY BLAZING RED	TRANSPARENT	CANDY BLAZING RED R-195C
4	NH-1 BLACK	SPORTS RED	R-195C CANDY BLAZING RED	TRANSPARENT	VIBRANT ORANGE (YR-250)

**F-27**  
**STRIPE / MARKS**

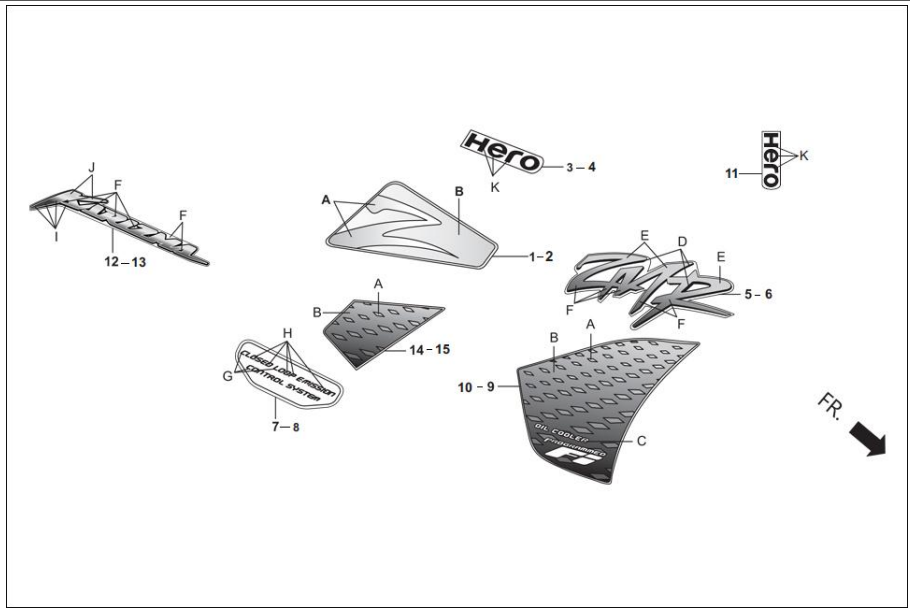

Service Item	F.R.T.	Group Number: F-27 Model :: Karizma ZMR (May, 2014)			
		Ref No.	Part Number	Description	Req.
		7	64321-AAR-000	MARK CLECS RTYPE	1

**SPECIFIED COLOUR CHART FOR MARK, CLECS RIGHT**

SPECIFIED COLOUR TYPE	<b>G</b>	<b>H</b>	<b>MAIN BODY COLOUR</b>
1	CHROME	NH-303 M MAT AXIS GRAY METALLIC	PANTHER BLACK METALLIC (NH-B08M)
			PEARL FADELESS WHITE (NH-341P)
			CANDY BLAZING RED R-195C
			VIBRANT ORANGE (YR-250)

**F-27**  
**STRIPE / MARKS**

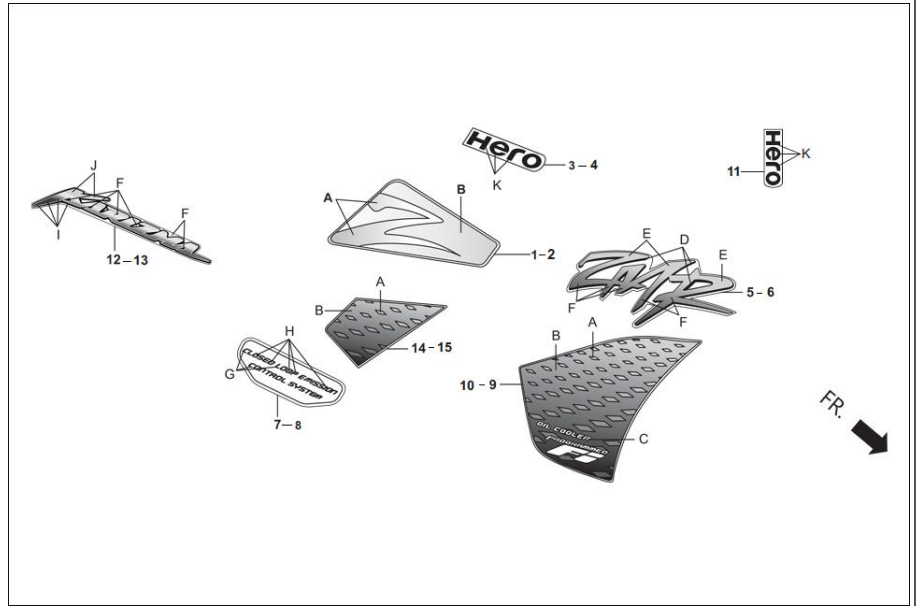

**Service Item**

**F.R.T.**

**Group Number:** F-27 **Model ::** Karizma ZMR (May, 2014)

<b>Ref No.</b>	<b>Part Number</b>	<b>Description</b>	<b>Req.</b>
8	64322-AAR-000	MARK CLECS LTYPE	1

**SPECIFIED COLOUR CHART FOR MARK, CLECS LEFT**

SPECIFIED COLOUR TYPE	<b>G</b>	<b>H</b>	<b>MAIN BODY COLOUR</b>
1	CHROME	NH-303 M MAT AXIS GRAY METALLIC	PANTHER BLACK METALLIC (NH-B08M)
			PEARL FADELESS WHITE (NH-341P)
			CANDY BLAZING RED R-195C
			VIBRANT ORANGE (YR-250)

**F-27**  
**STRIPE / MARKS**

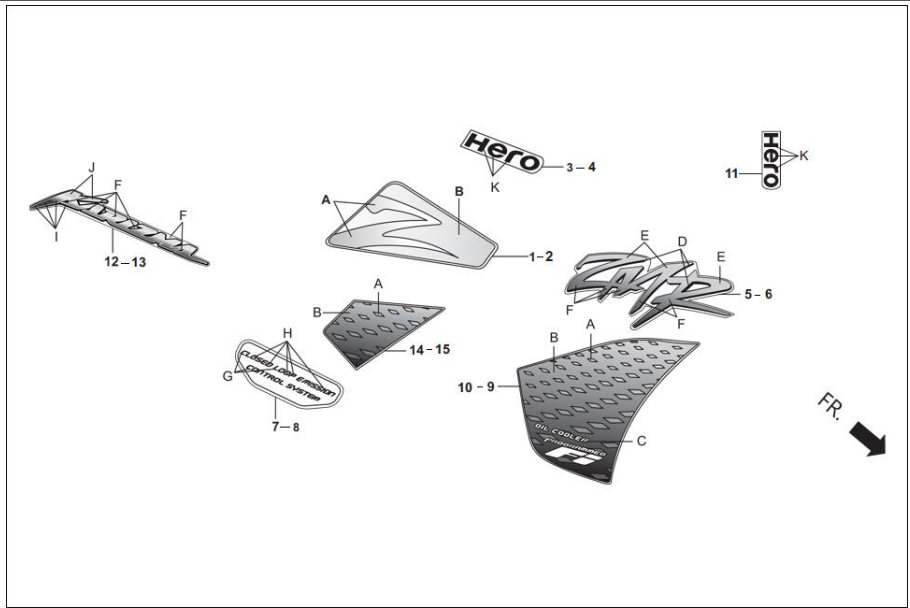

Service Item	F.R.T.	Group Number: F-27 Model :: Karizma ZMR (May, 2014)			
		Ref No.	Part Number	Description	Req.
		9	64323-AAR-000	STRIPE B R FAIRING SIDETYPE	1



**SPECIFIED COLOUR CHART FOR STRIPE B, RIGHT, FAIRING SIDE**

SPECIFIED COLOUR TYPE	<b>D</b>	<b>E</b>	<b>F</b>	<b>MAIN BODY COLOUR</b>
1	EBONY GRAY ME.	NH-1 BLACK	BRUSH LINES	PANTHER BLACK METALLIC (NH-B08M)
2	EBONY GRAY ME.	NH-1 BLACK	BRUSH LINES	PEARL FADELESS WHITE (NH-341P)
3	EBONY GRAY ME.	NH-1 BLACK	BRUSH LINES	CANDY BLAZING RED R-195C
4	EBONY GRAY ME.	NH-1 BLACK	BRUSH LINES	VIBRANT ORANGE (YR-250)

**F-27**  
**STRIPE / MARKS**

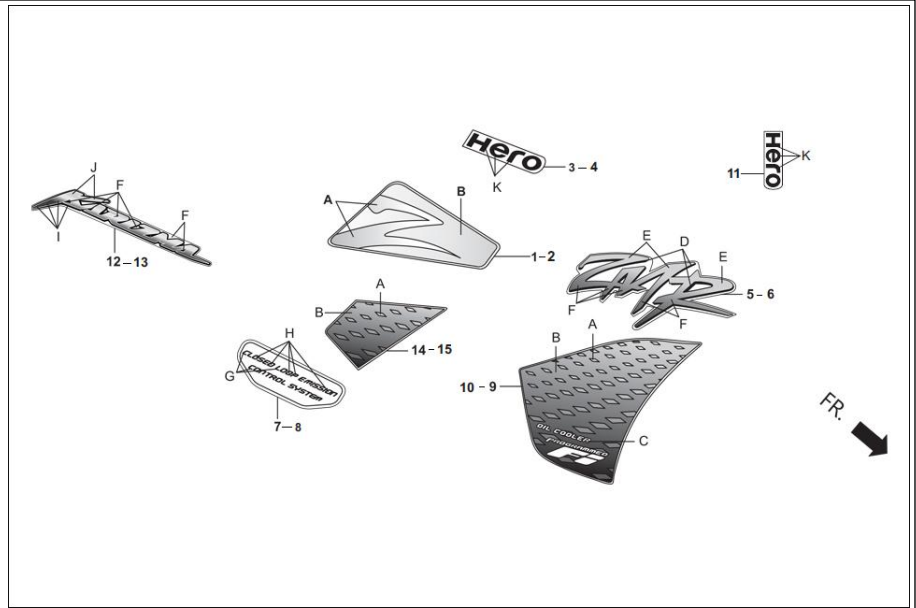

Service Item	F.R.T.	Group Number: F-27 Model :: Karizma ZMR (May, 2014)			
		Ref No.	Part Number	Description	Req.
		10	64324-AAR-000	STRIPE B L FAIRING SIDETYPE	1

**SPECIFIED COLOUR CHART FOR STRIPE B, LEFT, FAIRING SIDE**

SPECIFIED COLOUR TYPE	<b>D</b>	<b>E</b>	<b>F</b>	<b>MAIN BODY COLOUR</b>
1	EBONY GRAY ME.	NH-1 BLACK	BRUSH LINES	PANTHER BLACK METALLIC (NH-B08M)
2	EBONY GRAY ME.	NH-1 BLACK	BRUSH LINES	PEARL FADELESS WHITE (NH-341P)
3	EBONY GRAY ME.	NH-1 BLACK	BRUSH LINES	CANDY BLAZING RED R-195C
4	EBONY GRAY ME.	NH-1 BLACK	BRUSH LINES	VIBRANT ORANGE (YR-250)

**F-27**  
**STRIPE / MARKS**

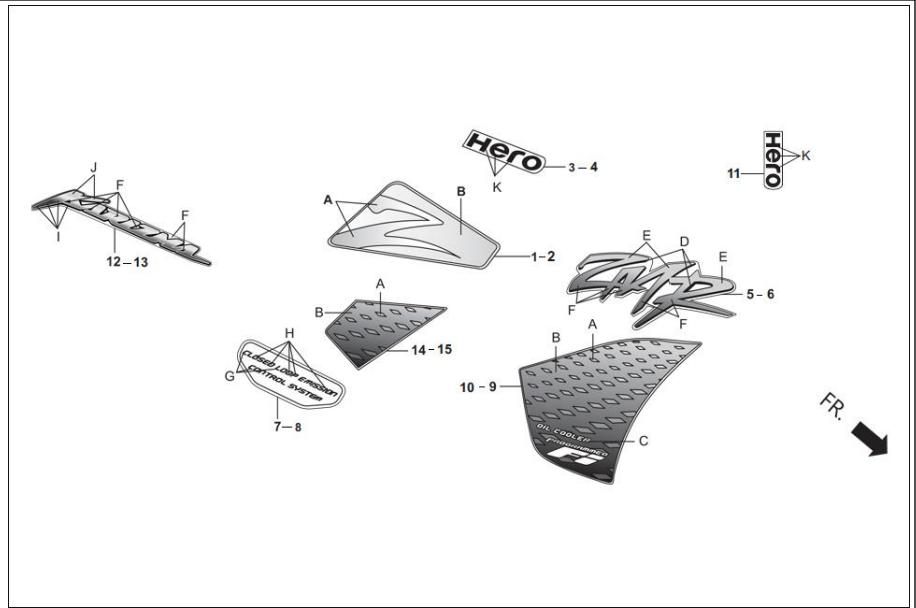

Service Item

F.R.T.

Group Number: F-27 Model :: Karizma ZMR (May, 2014)

Ref No.	Part Number	Description	Req.
11	86645-AAR-000R	MARK HERO FR(TYPE-1)	1
	86645-AAR-000S	MARK HERO FR(TYPE-2)	1

**SPECIFIED COLOUR CHART FOR MARK HERO, FR**

SPECIFIED COLOUR TYPE	<b>K</b>	<b>MAIN BODY COLOUR</b>
1	PEARL FADELESS WHITE (NH-341P)	PANTHER BLACK METALLIC (NH-B08M)
		PEARL FADELESS WHITE (NH-341P)
2	NH-BLACK	CANDY BLAZING RED R-195C
		VIBRANT ORANGE (YR-250)

**F-27**  
**STRIPE / MARKS**

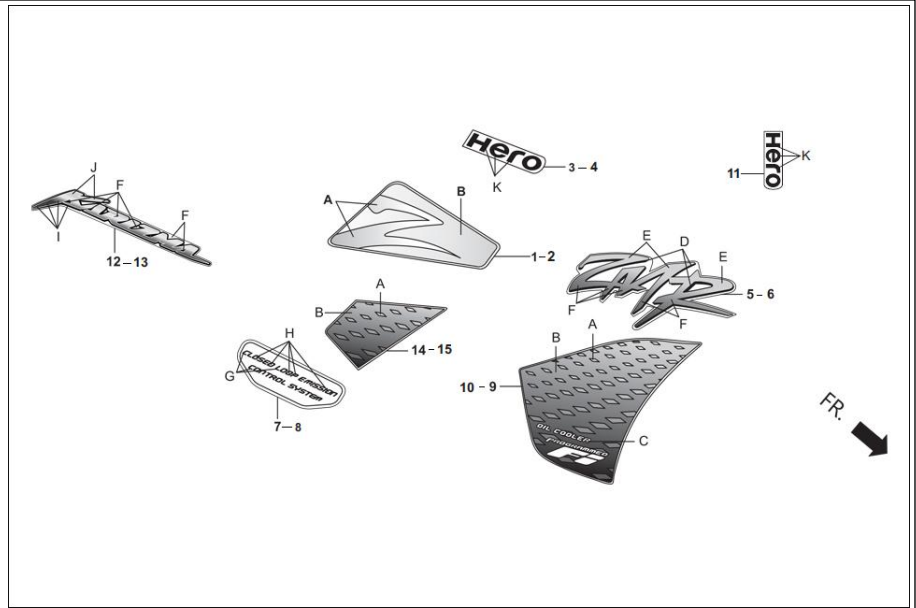

**Service Item**

**F.R.T.**

**Group Number: F-27 Model :: Karizma ZMR (May, 2014)**

Ref No.	Part Number	Description	Req.
12	86647-AAR-000R	STRIPE A R TAIL SEC BWK(TYPE-1)	1
	86647-AAR-000S	STRIPE A R TL S/BWK(TYPE-2)	1
	86647-AAR-000T	STRIPE A R TAIL SEC BWK(TYPE-3)	1
	86647-AAR-000U	STRIPE A R TAIL SEC BWK(TYPE-4)	1

**SPECIFIED COLOUR CHART FOR STRIPE A, R, TAIL SECTION BODYWORK**

SPECIFIED COLOUR TYPE	<b>I</b>	<b>J</b>	<b>F</b>	<b>MAIN BODY COLOUR</b>
1	NH-1 BLACK	HAIR LINE SILVER	PANTHER BLACK ME. (NH-B08M)	PANTHER BLACK METALLIC (NH-B08M)
2	NH-1 BLACK	HAIR LINE SILVER	PEARL FADELESS WHITE (NH-341P)	PEARL FADELESS WHITE (NH-341P)
3	NH-1 BLACK	HAIR LINE SILVER	CANDY BLAZING RED R-195C	CANDY BLAZING RED R-195C
4	NH-1 BLACK	HAIR LINE SILVER	VIBRANT ORANGE (YR-250)	VIBRANT ORANGE (YR-250)

**F-27**  
**STRIPE / MARKS**

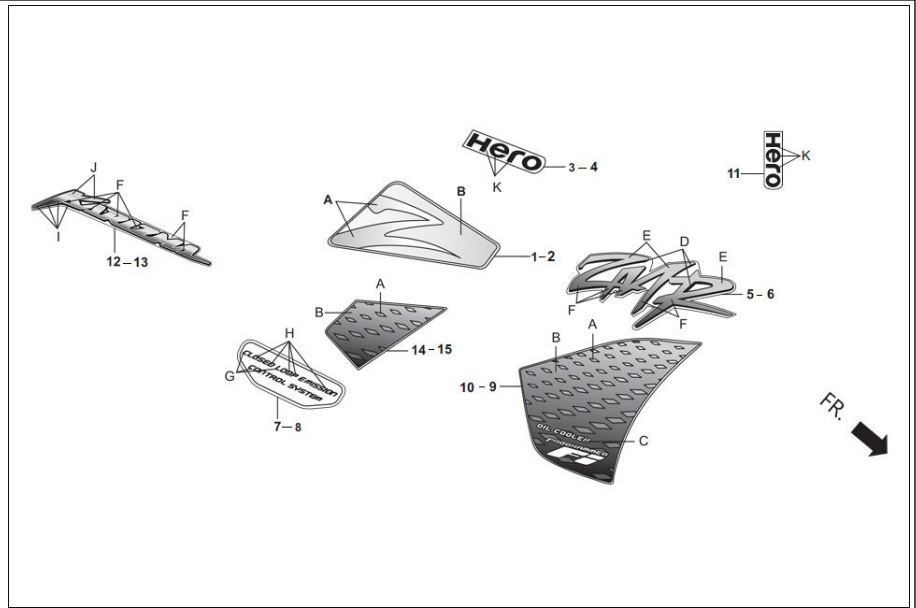

Service Item

F.R.T.

Group Number: F-27 Model :: Karizma ZMR (May, 2014)

Ref No.	Part Number	Description	Req.
13	86648-AAR-000R	STRIPE A L TAIL SEC BWK(TYPE-1)	1
	86648-AAR-000S	STRIPE A L TL S/BWK(TYPE-2)	1
	86648-AAR-000T	STRIPE A L TAIL SEC BWK(TYPE-3)	1
	86648-AAR-000U	STRIPE A L TAIL SEC BWK(TYPE-4)	1



**SPECIFIED COLOUR CHART FOR STRIPE A, L, TAIL SECTION BODYWORK**

SPECIFIED COLOUR TYPE	<b>I</b>	<b>J</b>	<b>F</b>	<b>MAIN BODY COLOUR</b>
1	NH-1 BLACK	HAIR LINE SILVER	PANTHER BLACK ME. (NH-B08M)	PANTHER BLACK METALLIC (NH-B08M)
2	NH-1 BLACK	HAIR LINE SILVER	PEARL FADELESS WHITE (NH-341P)	PEARL FADELESS WHITE (NH-341P)
3	NH-1 BLACK	HAIR LINE SILVER	CANDY BLAZING RED R-195C	CANDY BLAZING RED R-195C
4	NH-1 BLACK	HAIR LINE SILVER	VIBRANT ORANGE (YR-250)	VIBRANT ORANGE (YR-250)

**F-27**  
**STRIPE / MARKS**

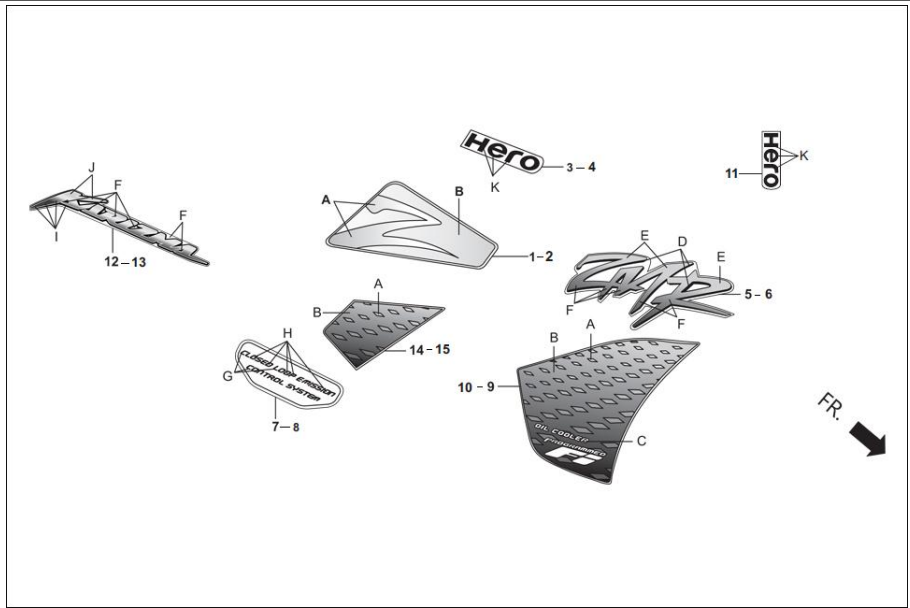

Service Item

F.R.T.

Group Number: F-27 Model :: Karizma ZMR (May, 2014)

Ref No.	Part Number	Description	Req.
14	86649-AAR-000	STRIPE B R TAIL SEC BWK	1

**SPECIFIED COLOUR CHART FOR STRIPE B, R, TAIL SECTION BODYWORK**

SPECIFIED COLOUR TYPE	<b>A</b>	<b>B</b>	<b>MAIN BODY COLOUR</b>
1	EBONY GRAY ME.	NH-1 BLACK	PANTHER BLACK METALLIC (NH-B08M)
1	EBONY GRAY ME.	NH-1 BLACK	PEARL FADELESS WHITE (NH-341P)
1	EBONY GRAY ME.	NH-1 BLACK	CANDY BLAZING RED R-195C
1	EBONY GRAY ME.	NH-1 BLACK	VIBRANT ORANGE (YR-250)

**F-27**  
**STRIPE / MARKS**

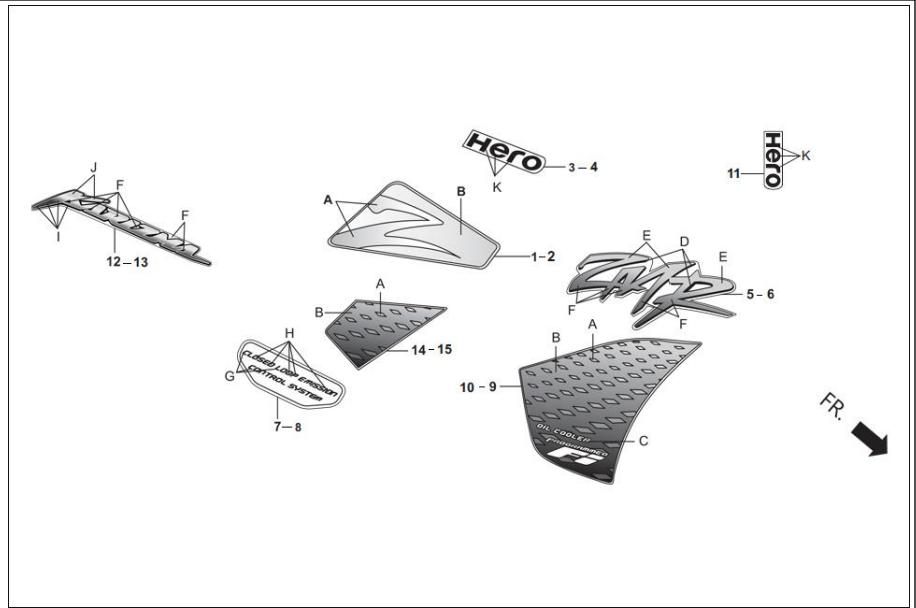

Service Item

F.R.T.

Group Number: F-27 Model :: Karizma ZMR (May, 2014)

Ref No.	Part Number	Description	Req.
15	86659-AAR-000	STRIPE B L TAIL SEC BWK	1

**SPECIFIED COLOUR CHART FOR STRIPE B, L, TAIL SECTION BODYWORK**

SPECIFIED COLOUR TYPE	<b>A</b>	<b>B</b>	<b>MAIN BODY COLOUR</b>
1	EBONY GRAY ME.	NH-1 BLACK	PANTHER BLACK METALLIC (NH-B08M)
1	EBONY GRAY ME.	NH-1 BLACK	PEARL FADELESS WHITE (NH-341P)
1	EBONY GRAY ME.	NH-1 BLACK	CANDY BLAZING RED R-195C
1	EBONY GRAY ME.	NH-1 BLACK	VIBRANT ORANGE (YR-250)

**F-28**  
SARI GUARD

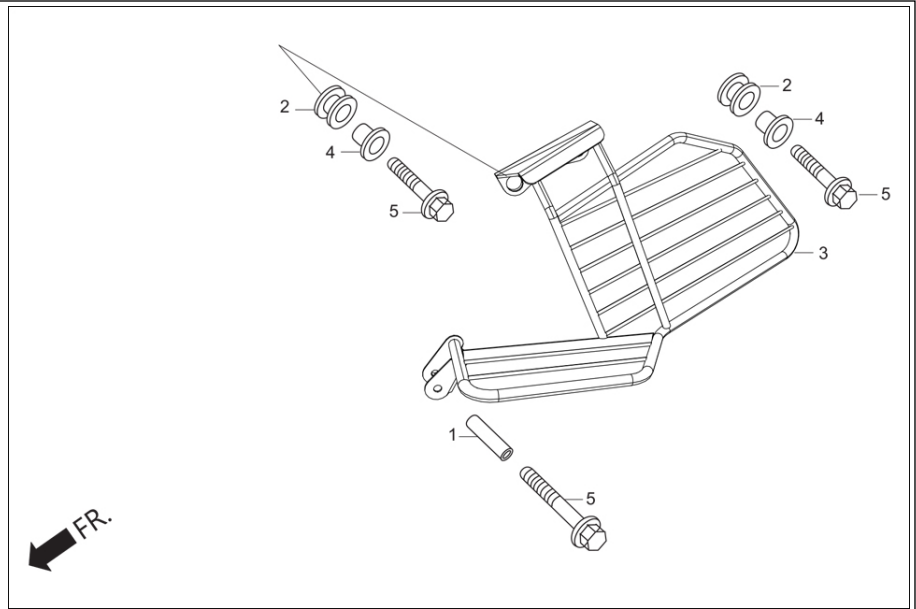

Service Item

F.R.T.

Group Number: F-28 Model :: Karizma ZMR (May, 2014)

Ref No.	Part Number	Description	Req.
1	18442-KFN-850	COLLAR, MUFF. MOUNT	1
2	50623-MAV-000	RUBBER, STEP MTG.	2
3	51103-AAR-000	SARI GUARD	1
4	90124-KAE-000	COLLAR, 8.7 X 17	2
5	95701-08035-00	BOLT, FLANGE, 8 X 35	3

## F-29 CAUTION LABEL

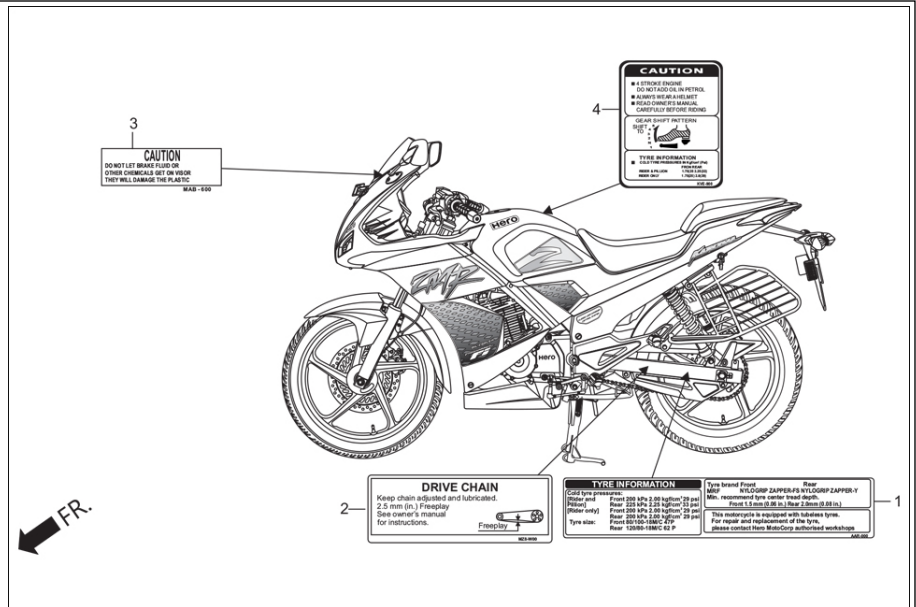

Service Item

F.R.T.

Group Number: F-29 Model :: Karizma ZMR (May, 2014)

Ref No.	Part Number	Description	Req.
1	87505-AAR-000	LABEL TYRE	1
2	87507-MZ8-W00	LABEL, CHAIN DRIVE	1
3	87522-MAB-600	LABEL, VISOR CAUTION	1
4	87560-AAB-H00	LABEL DRIVE	1

# **PARTS INDEX**



<b>PART NO</b>	<b>BLOCK</b>	<b>PART NO</b>	<b>BLOCK</b>
3310B-AAR-001	F-1	14776-107-010	E-3
3340B-AAR-001	F-22	14781-HA0-770	E-3
3345B-AAR-001	F-22	15100-AAR-101	E-8A
3360B-AAR-001	F-22	15100-AAR-101	E-8A
3365B-AAR-001	F-22	15421-107-000	E-8
3370B-AAR-001	F-23	15426-107-000	E-8
5310B-AAR-000	F-4	15430-440-030	E-8A
5315B-AAR-000	F-4	15436-107-000	E-8A
06435-KRY-971	F-10A	15441-KCS-650	E-8A
06451-GE2-405L	F-8	15446-107-000	E-8A
06451-MA7-405	F-10A	15451-KRY-970	E-6
06455-GCR-016L	F-8	15459-KWK-900	E-8A
7710A-AAR-000	F-12	15510-KRY-970	F-1C
7730A-AAR-000	F-12	15520-KRY-970	F-1C
11100-KRY-970	E-8	15600-AAR-000	F-1C
11108-KHA-940	E-10	15650-KRY-970	E-5
11191-KCN-010	E-8	15772-KTN-900	F-13
11200-KRY-960	E-8	16060-AAR-001	E-13
11330-AAR-H00	E-5	16080-AAR-001	E-13
11341-KRY-970	E-7	16081-AAR-001	E-13
11355-KRY-970	E-7	16082-AAR-001	E-13
11361-AAR-000	E-7	16083-AAR-001	E-13
11363-437-620	E-7	16163-GHB-610	F-13
11370-AAR-000	E-7	16169-AAR-001	E-13
11393-KCN-010	E-5	16210-KRY-971	E-1
11395-KCN-010	E-7	16221-KRY-970	E-1
12000-AAR-000	E-1	16222-KSP-910	E-1
12100-KRY-960	E-2	16410-AAR-001	E-13
12191-KCN-010	E-2	16422-AAR-001	E-13

12195-KRC-920	E-2	16430-AAR-001	E-13
12204-439-305	E-1	16432-AAR-001	E-13
12206-KCN-305	E-1	16433-AAR-001	E-13
12208-KCS-920	E-3	16460-AAR-001	E-13
12251-KT0-711	E-1	16472-AAR-001	E-13
12271-383-000	E-1	16700-AAR-001	F-13
12331-KRY-960	E-1	16711-KRY-970	F-13
12339-KT0-711	E-1	16712-KRY-970	F-13
12361-KEZ-900	E-1	16713-KRY-970	F-13
12361-KEZ-900	E-8	16720-KRY-970H	F-13
13000-KRY-903	E-9	16910-AAR-H71	F-13
13011-KRY-900	E-9	17199-KRY-970	F-13
13101-AAR-001	E-9	17210-KRY-970H	F-15
13111-440-000	E-9	17211-AAP-000	F-15
13201-KFB-300	E-9	17213-KRY-900	F-15
13380-KCN-300	E-9	17214-KRY-900	F-15
14100-AAR-000	E-3	17219-KRY-970	F-15
14311-KN6-931L	E-9	17220-KRY-970H	F-15
14321-KRY-970	E-4	17232-KRY-970	F-24A
14401-KFB-751	E-4	17234-KS4-770	F-15
14431-KEH-900R	E-3	17253-KRY-970	F-15
14451-437-000	E-3	17311-KRY-970	F-15
14456-KG2-950	E-3	17312-KFN-880	F-15
14500-KBB-900	E-4	17324-AAR-000	F-15
14513-KBB-900	E-8	17370-382-870	F-15
14520-KRY-971	E-4	17371-KRY-900	F-15
14523-KEH-910	E-4	17500-AAR-000R	F-13
14535-437-000	E-4	17500-AAR-000S	F-13
14550-KFB-000	E-4	17500-AAR-000T	F-13
14711-KBB-900	E-3	17500-AAR-000U	F-13

14721-KBB-900	E-3	17506-AAR-000	F-12
14751-KEH-910	E-3	17506-KRY-900	F-13
14761-KEH-910	E-3	17507-AAR-H80ZA	F-27
14771-107-020	E-3	17507-AAR-H80ZB	F-27
14775-107-000	E-3	17507-AAR-H80ZC	F-27

<b>PART NO</b>	<b>BLOCK</b>	<b>PART NO</b>	<b>BLOCK</b>
17507-AAR-H80ZD	F-27	23471-KBB-900	E-10
17507-AAR-000R	F-27	23481-KBB-900	E-10
17507-AAR-000S	F-27	23491-KBB-900	E-10
17508-AAR-H80ZA	F-27	23501-KRY-900	E-10
17508-AAR-H80ZB	F-27	23511-KRY-970	E-10
17508-AAR-H80ZC	F-27	23801-KRY-970	E-10
17508-AAR-H80ZD	F-27	23811-KR3-600	E-10
17508-AAR-000R	F-27	24211-KW1-900	E-12
17508-AAR-000S	F-27	24221-KBB-900	E-12
17570-AAR-001	F-13	24231-KW1-900	E-12
17611-KRY-970	F-13	24241-KCS-650	E-12
17613-MV4-000	F-13	24301-KCN-000	E-12
17620-KRY-971	F-13	24411-KCN-000	E-12
17622-GB7-900	E-7	24430-KW1-900	E-12
17681-KRY-970	F-13	24435-KCN-000	E-12
17682-KRY-970	F-13	24610-KC6-000	E-12
17683-KRY-970	F-13	24621-107-760	E-12
17910-AAR-000	F-3A	24631-107-000	E-12
17920-AAR-000	F-3A	24651-107-000	E-12
18291-KRY-930	F-16	24701-KRY-970	F-18
18293-KPK-900	F-16	24711-KRY-970	F-18
18300-AAR-000	F-16	24720-KRY-970	F-18
18311-AAR-000	F-16	24721-GS3-000	F-18
18312-AAR-000	F-16	24721-KRY-970	F-18
18317-KRY-970	F-16	24781-KR3-770	F-18
18345-MBT-610	F-16	28110-KEW-900	E-7A
18421-438-000	F-16	28114-KN6-930	E-7A
18421-438-000	F-17	28125-KFC-791L	E-7A
18442-KRC-900	F-16	28130-KFB-000	E-7

18442-KFN-850	F-28	28132-KN6-930	E-7
19051-KA3-830	F-1C	28140-KFB-000	E-7
19052-KV0-000	F-1	28142-KW1-900	E-7
19052-KV0-000	F-1A	28333-300-000	F-17
19052-MN8-000	F-1C	30510-AAR-001	F-24
19052-KV0-000	F-12	30520-ML7-000	F-24
19052-KV0-000	F-15	30700-KTC-A21	F-24
22100-KRY-900R	E-6	31100-AAR-001	E-7A
22121-KPK-900	E-6	31110-AAR-001	E-7A
22125-KW7-900	E-6	31120-KRY-971	E-7A
22131-KPM-850	E-6	31200-KPS-A11	E-7B
22201-KBW-900	E-6	31201-MEW-921	E-7B
22201-KPM-850	E-6	31202-MEW-921	E-7B
22201-MJ8-000	E-6	31203-MEW-921	E-7B
22321-KE8-000	E-6	31204-MEW-921	E-7B
22355-KPK-900	E-6	31205-HP5-601	E-7B
22361-KPK-900	E-6	31206-MEW-921	E-7B
22366-KFB-000	E-6	31207-HP5-601	E-7B
22401-KRY-900	E-6	31208-MEW-921	E-7B
22402-KPM-850	E-6	31209-MEW-921	E-7B
22810-KBB-900	E-5	31210-MEW-921	E-7B
22815-428-000	E-5	31500-KRY-801	F-24A
22838-437-000	E-8	31600-KVK-901	F-24
22870-KRY-970	F-3A	31700-124-000	F-24
22871-437-000	F-3A	31918-HM5-630	E-1
23121-KBB-900	E-8A	32100-AAR-000	F-24
23211-KHA-940	E-10	32401-AAR-001	F-24A
23221-AAR-000	E-10	32406-MT3-610	F-24A
23426-KBB-900	E-10	32410-KRY-970	F-24A
23427-KW1-900	E-10	32413-KRY-970	F-24A

23431-KRY-900	E-10	32414-MW0-000	F-24A
23441-KBB-900	E-10	32418-KRY-970	F-24A
23451-KRY-970	E-10	32601-KRY-971	F-24A
23452-KW1-900	E-10	32975-KRY-970	E-7A
23461-KBB-900	E-10	32976-KCT-690	E-8

<b>PART NO</b>	<b>BLOCK</b>	<b>PART NO</b>	<b>BLOCK</b>
33110-AAP-001	F-1	38120-AAR-000	F-25
33112-AAP-001	F-1	38301-KWA-831	F-24
33150-AAR-001	F-1	38306-GE7-000	F-24
33401-AAR-001	F-22	38501-MCS-G00	F-24
33402-AAR-001	F-22	38770-AAR-001	F-24
33405-AAR-001	F-22	40510-AAR-000	F-19
33408-AAR-001	F-22	40520-AAR-000	F-19
33451-AAR-001	F-22	40530-AAR-000	F-19
33452-AAR-001	F-22	40543-KRY-900	F-19
33605-AAR-001	F-22	40544-KRY-900	F-19
33619-459-840A	F-16	40546-KRY-900	F-19
33655-AAR-001	F-22	41201-AAR-000	F-11
33703-AAR-001	F-23	41241-KSP-900	F-11
33704-AAR-001	F-23	42301-AAR-000	F-11
33714-KL3-620	F-25	42303-KRY-931	F-11
33720-AAR-001	F-23	42311-KRY-930	F-11
33742-AAR-001	F-21	42313-KRY-970	F-19
33743-AAR-001	F-21	42601-AAR-000	F-11
33941-AAR-001	F-22	42611-KRY-930	F-11
33946-AAR-001	F-22	42620-AAR-000	F-11
34351-AAR-001	F-23	42704-MER-D00	F-9
34901-AAP-001	F-1	42704-MER-D00	F-11
34908-AAB-401	F-22	42705-MER-D00	F-9
34930-AAC-700	F-22	42705-MER-D00	F-11
35010-AAR-H70	F-4	42706-MB0-000	F-9
35100-AAR-H71	F-4	42706-MB0-000	F-11
35113-KZJ-H00	F-4	42711-AAR-000	F-11
35114-KZJ-H00	F-4	42753-KWF-90099	F-9
35121-KZJ-H00	F-4	42753-KWF-90099	F-11

35122-KZJ-H00	F-4	43102-AAR-000	F-10
35140-AAR-002	F-18A	43107-MA7-006	F-10A
35150-KRY-971	F-3A	43114-KW6-842L	F-8
35152-KRY-970	F-3A	43114-KW6-842L	F-10A
35161-GBJ-M30	F-24	43115-AAR-000	F-10A
35162-MFA-D01	F-24	43150-KRY-972	F-10A
35163-MBZ-C50	F-24	43155-KRY-970	F-10
35200-KRY-971	F-3A	43190-KRY-971	F-10A
35330-413-003	F-3A	43215-KGH-901	F-10A
35340-MA5-670L	F-3	43251-KRY-981	F-11
35350-KFN-850	F-18	43310-AAR-000	F-10
35357-KCT-690	F-18	43352-568-003L	F-8
35400-AAR-001	F-24	43352-568-003L	F-10A
35505-SA5-003	F-2	43353-461-771L	F-8
35750-KCS-920	E-8	43353-461-771L	F-10A
35752-KRY-900A	E-7	43503-MEE-006	F-10
35753-KCS-920	E-12	43504-MB2-006	F-10
35850-KR3-870	F-24A	43510-KRY-971	F-10
35856-KBG-007	F-24A	43511-KW7-881	F-10
36532-KRY-971	E-1	43512-KRY-971	F-10
36533-KRY-970	E-1	43514-KS6-701	F-10
36538-KWF-940	E-1	43520-MJ6-315	F-10
37100-AAR-001	F-2	43530-MV9-006	F-10
37105-KRY-970	F-2	44301-KPL-900	F-9
37105-KRJ-901	F-2	44311-KRY-900	F-9
37110-AAR-001	F-2	44601-AAR-H71	F-9
37112-KRY-971	F-2	44620-400-000	F-9
37214-KV7-671	F-2	44711-KRY-971	F-9
37215-AAP-001	F-1	44800-KRY-971	F-9
37612-KRY-981	F-2	45107-MN5-006L	F-8



37613-KRY-971	F-2	45108-ML4-006L	F-8
37750-AAR-001	E-1	45111-MAJ-G41	F-10A
37800-KRY-961	F-13	45126-KRY-970	F-3
38110-KRY-971	F-25	45131-GE2-006L	F-8
38117-KFE-701	F-25	45131-GE2-006L	F-10A

<b>PART NO</b>	<b>BLOCK</b>	<b>PART NO</b>	<b>BLOCK</b>
45132-166-016L	F-8	50644-445-840	F-17
45132-166-016L	F-10A	50661-KRY-970	F-17
45133-MA3-006L	F-8	50718-KRY-970	F-17
45133-MA3-006L	F-10A	50720-KRY-970	F-17
45155-KRY-970	F-3	50730-KRY-970	F-17
45155-KRY-970	F-5	51103-AAR-000	F-28
45156-KRY-900	F-3	51400-KRY-971	F-7
45160-KRY-970	F-5	51401-KRY-971	F-7
45163-KRY-970	F-9	51410-KRY-971	F-7
45164-KRY-970	F-9	51412-KSP-901	F-7
45165-KRY-970	F-5	51412-KFN-851	F-7
45170-KRY-970	F-5	51414-KK4-003	F-7
45201-GT4-691L	F-8	51420-KRY-971	F-7
45203-MG3-016L	F-8	51432-KFN-851	F-7
45203-MCC-006	F-10A	51437-KVN-901	F-7
45215-KA3-732L	F-8	51440-KFN-851	F-7
45216-166-006L	F-8	51488-KTN-701	F-20
45216-166-006L	F-10A	51500-KRY-971	F-7
45216-KPP-861	F-10A	51520-KRY-971	F-7
45251-KRY-981	F-9	52110-AAR-000	F-19
45290-KGB-611L	F-8	52142-KRY-970	F-19
45504-410-003L	F-3	52144-GC4-005	F-19
45510-KRY-972	F-3	52170-AAR-000	F-19
45512-MA6-006	F-3	52400-KRY-971	F-20
45513-HA2-006L	F-3	52486-KTN-701	F-20
45513-GW0-911	F-10	52489-399-600	F-20
45517-166-000	F-3	53104-KRY-970	F-4
45517-166-000	F-3A	53105-KRY-970	F-4
45520-GE2-006	F-3	53107-KTT-910	F-4

45520-GW0-911	F-10	53108-MJ0-000	F-4
45521-K21-901	F-3	53127-KRY-970	F-4
45521-GW0-911	F-10	53128-KRY-970	F-4
45530-471-831L	F-3	53140-KRY-980	F-3A
46182-MEL-D21	F-10	53141-KRY-970	F-3A
46500-KRY-980	F-18	53166-KRY-980	F-3A
46504-KV6-702	F-10	53172-KRY-970	F-3A
46514-KN5-670	F-18	53174-116-670	F-3A
46515-KRY-970	F-18	53175-KFN-850L	F-3
50100-AAR-000	F-25	53178-KFN-850	F-3A
50137-AAR-000	F-25	53182-KFN-850	F-3A
50153-KRY-970	F-25	53192-349-690	F-3A
50161-AAR-000	F-25	53200-KRY-970	F-5
50197-KRY-900	F-25	53211-268-010	F-5
50199-KRY-900	F-25	53212-200-000	F-5
50301-KTR-900	F-5	53214-200-000	F-5
50351-KRY-960	F-25	53215-KTR-900	F-5
50353-KRY-970	F-25	53220-KRY-970	F-5
50383-KRC-900	F-24A	53222-KTR-900	F-5
50400-AAR-000	F-25	53230-KRY-970	F-4
50450-AAR-000	F-25	61100-AAR-000R	F-6
50500-KRY-970	F-18A	61100-AAR-000S	F-6
50505-KCC-900	F-16	61100-AAR-000T	F-6
50526-KCT-690	F-18A	61100-AAR-000U	F-6
50530-KRY-970	F-18A	61102-KRY-970	F-6
50612-KRY-970	F-17	61103-KRY-900	F-6
50617-445-840	F-17	61105-KTC-900	F-6
50619-KRY-970	F-17	61301-AAR-000	F-1A
50623-MAV-000	F-28	61309-AAR-000	F-1A
50630-KRY-970	F-17	64100-AAR-000	F-1A

50638-KRY-970	F-17	64200-AAR-000R	F-1A
50639-KRY-970	F-17	64200-AAR-000S	F-1A
50640-KRY-970	F-17	64200-AAR-000T	F-1A
50642-KRY-970	F-17	64200-AAR-000U	F-1A
50643-KRY-970	F-17	64206-AAR-000	F-1A

<b>PART NO</b>	<b>BLOCK</b>	<b>PART NO</b>	<b>BLOCK</b>
64207-AAR-000	F-1A	83551-300-000	F-13
64216-AAR-000R	F-27	83551-300-000	F-25
64216-AAR-000S	F-27	84701-AAR-000	F-21
64216-AAR-000T	F-27	84701-KTC-900	F-21
64216-AAR-000U	F-27	84701-P26-D00A	F-21A
64217-AAR-000R	F-27	86645-AAR-000R	F-27
64217-AAR-000S	F-27	86645-AAR-000S	F-27
64217-AAR-000T	F-27	86647-AAR-000R	F-27
64217-AAR-000U	F-27	86647-AAR-000S	F-27
64258-AAR-000R	F-1A	86647-AAR-000T	F-27
64258-AAR-000S	F-1A	86647-AAR-000U	F-27
64258-AAR-000T	F-1A	86648-AAR-000R	F-27
64258-AAR-000U	F-1A	86648-AAR-000S	F-27
64301-AAR-000	F-1A	86648-AAR-000T	F-27
64302-AAR-000	F-1A	86648-AAR-000U	F-27
64305-AAR-000	F-1A	86649-AAR-000	F-27
64310-198-D20A	F-21A	86659-AAR-000	F-27
64315-AAR-000	F-1A	87505-AAR-000	F-29
64320-AAR-000	F-1A	87507-MZ8-W00	F-29
64321-AAR-000	F-27	87522-MAB-600	F-29
64322-AAR-000	F-27	87560-AAB-H00	F-29
64323-AAR-000	F-27	88110-AAR-H81ZA	F-3A
64324-AAR-000	F-27	88110-AAR-H81ZB	F-3A
64330-AAR-000	F-1A	88110-AAR-H81ZC	F-3A
64348-AAR-000R	F-1A	88110-AAR-H81ZD	F-3A
64348-AAR-000S	F-1A	88115-KRY-970	F-3A
64348-AAR-000T	F-1A	88116-KRY-970	F-3A
64348-AAR-000U	F-1A	88120-AAR-H81ZA	F-3A
64358-AAR-000R	F-1A	88120-AAR-H81ZB	F-3A

64358-AAR-000S	F-1A	88120-AAR-H81ZC	F-3A
64358-AAR-000T	F-1A	88120-AAR-H81ZD	F-3A
64358-AAR-000U	F-1A	89102-538-000	F-26
64510-AAR-000	F-1A	89102-AAC-000	F-26
64523-AAR-000	F-1A	89103-538-000	F-26
77100-AAR-000	F-12	89213-AAR-000	F-26
77110-ML7-922	F-12	89216-AAD-H00	F-26
77156-AAR-000	F-12	90002-KW1-900	E-4
77204-AAR-000	F-12	90004-GHB-700	E-1
77205-AAR-000	F-12	90005-KY7-000	E-4
77206-AAR-000	F-12	90006-MEE-000	E-1
77217-AAR-000	F-12	90012-KN6-930L	E-3
77218-AAR-000	F-12	90019-399-010	F-25
77220-KY6-000	F-12	90023-KW1-900	E-12
77234-AAR-000R	F-12	90031-KFB-000L	E-8
77234-AAR-000S	F-12	90032-KFB-000	E-8
77234-AAR-000T	F-12	90050-357-000	E-6
77234-AAR-000U	F-12	90071-MG8-000	E-4
77244-AAR-000R	F-12	90071-MB0-000	E-7B
77244-AAR-000S	F-12	90084-KRY-970	E-7
77244-AAR-000T	F-12	90087-KRY-970	E-7
77244-AAR-000U	F-12	90089-KAS-900	E-7A
77300-AAR-000	F-12	90091-MM5-640	E-1
80100-AAR-000	F-21	90092-KE5-000	E-7A
80101-KFN-850	F-13	90100-KRY-970	F-4
80250-AAR-000	F-21	90101-AAP-000	E-7A
80350-AAR-000	F-21A	90101-440-000	E-8A
80983-AAR-000	F-21A	90103-MCS-G00	F-10
83403-AAR-000	F-21	90103-AAR-000	F-25
83407-KCC-902	F-24A	90105-KVN-900	F-1

83520-AAR-000	F-21	90105--KRY-970	F-1A
83545-KCJ-690	F-1	90105-KVN-900	F-1A
83545-KCJ-690	F-12	90105-KL8-741	F-9
83545-KCJ-690	F-15	90105-KL8-741	F-11
83551-300-000	F-1A	90105-KRY-970	F-12

<b>PART NO</b>	<b>BLOCK</b>	<b>PART NO</b>	<b>BLOCK</b>
90105-KRY-970	F-21	90488-425-000	E-4
90107-GZ4-670	F-12	90501-KRY-970	F-2
90107-GN1-010	F-18A	90502-KEZ-900	E-7
90109-SB6-000	F-1A	90502-155-000	F-18
90111-KW3-000	F-1A	90503-KTR-900	F-4
90111-187-000	F-21	90504-964-000	F-1A
90111-KW3-000	F-21	90505-425-000	F-19
90111-187-000	F-21A	90521-292-000	F-7
90111-MR5-000	F-24A	90534-MV4-000	F-13
90113-438-000	F-3A	90544-KFN-851	F-7
90113-AAR-000	F-25	90545-300-000	F-3
90114-166-000L	F-3	90545-300-000	F-10
90115-MV9-000	F-17	90556-044-000	F-19
90116-KAG-900	F-7	90559-KRY-970	F-11
90116-ME9-000	F-21	90560-KRY-970	F-11
90121-KBW-900	F-19	90563-355-000	F-23
90122-KVT-941	F-24A	90601-GFC-780	F-4
90123-KSP-871	F-7	90601-KFN-851	F-7
90124-KAE-000	F-28	90601-KAF-003	F-13
90127-KRY-970	F-10A	90601-KAF-003	F-15
90128-KRY-970	F-3A	90601-KAF-003	F-18
90130-MEE-000	F-3A	90605-200-000	E-10
90145-MS9-610	F-3	90651-MA5-671L	F-3
90145-MS9-610	F-10	90651-KRY-970	F-7
90155-KY4-900	F-8	90651-MK3-780	F-15
90155-KY4-900	F-10A	90651-KV6-003	F-24
90155-AAR-000	F-10A	90701-KFN-850	E-5
90191-KRY-970	F-4	90703-HC4-000	E-7
90206-250-000	E-3	90703-HC4-000	E-8



90231-KB5-720	E-6	90741-KFB-000	E-9
90231-KCS-920	E-8A	90751-KRY-970	F-4
90301-KRY-970	F-1C	91001-KCN-003	E-9
90304-KSP-900	F-4	91005-KCN-003	E-10
90304-KCS-920	F-11	91008-KK6-000	E-6
90304-KFN-850	F-18A	91008-KCS-920	E-8
90305-KVN-900	F-11	91015-KEH-910	E-10
90305-KSP-900	F-16	91053-719-005	E-5
90305-KVN-900	F-19	91102-KC6-003	E-9
90306-KST-942	F-9	91103-KC6-003	E-9
90306-KVT-941	F-24A	91104-KC6-003	E-9
90320-GC3-000	F-1A	91105-KW3-003	E-9
90320-GC3-000	F-12	91106-KCS-920	E-8
90320-GC3-000	F-21	91201-KEH-910	E-5
90321-MR8-000	F-3A	91201-KCS-920	E-10
90344-KEV-900	F-1	91206-KCS-920	E-8
90380-AAR-001	F-22	91212-422-006	F-10
90380-AAR-001	F-25	91251-KPH-901	F-9
90403-KN6-930	E-7A	91251-KPH-901	F-9
90408-KW1-900	E-12	91253-KSP-901	F-11
90417-041-000	E-7	91254-GAA-003R	F-7
90434-KN6-930	E-8A	91254-KS6-003	F-19
90442-028-000	E-1	91255-GAA-003R	F-7
90443-107-000	E-1	91257-230-003	F-11
90443-MB0-000	E-1	91301-107-000	E-1
90443-107-000	F-25	91301-200-000	E-1
90451-107-000	E-10	91301-AAR-001	E-13
90451-365-000	E-10	91303-KCS-920	E-1
90451-001-000	E-12	91303-377-000	E-7
90452-437-000	E-10	91303-KCS-920	E-8

90454-107-000	E-10	91304-KRM-840	E-1
90455-107-000	E-10	91304-MZ0-760	E-7
90461-KPK-900	E-6	91304-KK3-830	E-8A
90471-KW1-900	E-9	91305-MC7-000	F-13
90475-703-000	E-4	91306-MG3-000	E-4

<b>PART NO</b>	<b>BLOCK</b>	<b>PART NO</b>	<b>BLOCK</b>
91307-KRM-840	E-5	94101-05000	F-21A
91309-425-003	E-7B	94102-08000	F-17
91312-107-000	E-8	94103-10000	F-16
91314-ME5-003	F-1C	94103-06000	F-18
91320-MB0-000	E-7B	94201-20150	F-10
91352-KSP-900	F-11	94201-16120	F-17
91356-KEH-910	E-7	94201-20150	F-17
91356-KAG-900	F-7	94201-20150	F-18
91405-KFN-850	F-15	94201-30300	F-18A
91406-KFN-850	F-15	94201-20150	F-19
91463-393-780	F-15	94251-08000	E-8A
91547-SF4-003	F-24	94301-08140	E-1
92000-06025-0A	E-12	94301-10200	E-2
92000-06012-0A	F-21A	94301-08140	E-5
92101-05020-0A	E-8A	94305-20102	F-10
92101-06010-0A	E-10	94510-12000L	E-12
92101-06020-4J	F-24	94510-14000	E-12
92900-08025-0E	E-1	94601-15000	E-9
92915-10025-0E	F-11	95002-02130	F-13
93500-04025-0G	F-15	95002-02130	F-15
93500-05016-0A	F-15	95002-80000	F-15
93500-05010-1G	F-21A	95003-37015-31	F-15
93600-06016-0A	E-3	95005-12280-20	F-15
93600-04012-0A	E-8A	95014-71702	F-18A
93600-04012-1GL	F-2	95014-72102	F-18A
93600-04012-1GL	F-3	95015-54000	F-10
93600-04045-1G	F-10	95018-50250	F-15
93700-05012-0A	E-8A	95020-15100	F-11
93891-05008-00	F-4	95701-06012-00	E-8

93892-05012-18L	E-7B	95701-06025-00	F-1A
93892-AAR-001	E-13	95701-06016-07	F-1C
93892-05020-07	F-3A	95701-06025-00	F-1C
93892-05025-07	F-3A	95701-08035-00	F-4
93892-05035-07	F-3A	95701-06012-07	F-5
93892-05045-07	F-3A	95701-08030-07	F-5
93893-04012-17L	F-3	95701-06012-00	F-10
93893-04012-17L	F-10	95701-06022-08	F-10
93901-25020	F-19	95701-06012-00	F-12
93903-25210	F-1A	95701-06016-00	F-13
93903-22420	F-2	95701-08025-08	F-13
93903-25210	F-12	95701-06020-00	F-15
93903-25210	F-21	95701-10020-00	F-16
93903-25210	F-22	95701-10025-00	F-17
94001-06000-0S	F-2	95701-06012-00	F-19
94001-06000-0S	F-19	95701-06012-00	F-21
94001-08000-0S	F-19	95701-10014-00	F-21A
94001-12000-0S	F-20	95701-06008-00	F-24A
94002-08000-0S	F-10	95701-06012-00	F-24A
94002-08080-0S	F-22	95701-06012-00	F-25
94050-06000	F-3	95701-06020-07	F-25
94050-06000	F-3A	95701-08016-00	F-25
94050-06000	F-13	95701-08025-00	F-25
94050-10000	F-16	95701-08035-00	F-28
94050-08000	F-17	95801-10040-02	F-4
94050-06000	F-21	95801-06032-00	F-6
94050-05000	F-21A	95801-10055-00	F-16
94050-06000	F-23	95801-08028-07	F-18
94050-04000	F-24	95801-10035-00	F-20
94050-08000	F-25	95801-AAR-000	F-25

94101-06000	E-1	95802-AAR-000	F-25
94101-05000	F-15	95803-AAR-000	F-25
94101-06000	F-17	96001-06025-00	E-1
94101-12800	F-20	96001-06040-00	E-5
94101-06000	F-21A	96001-06050-00	E-5

<b>PART NO</b>	<b>BLOCK</b>
96001-06020-00	E-7
96001-06028-00	E-7
96001-06040-00	E-7
96001-06060-00	E-7
96001-06070-00	E-7
96001-06080-00	E-7
96001-06014-00	E-8
96001-06050-00	E-8
96001-06060-00	E-8
96001-06020-00	F-1C
96001-06012-07	F-3
96001-06022-07	F-3
96001-06022-07	F-3A
96001-06012-07	F-5
96001-06014-00	F-5
96001-06016-02	F-16
96001-06012-02	F-16
96001-06012-00	F-18
96001-06020-00	F-18
96100-62040-00	E-10
96140-63020-10	F-11
96150-63010-10	F-9
96150-60050-10	F-11
96211-06000	F-5
96211-08000	F-17
96220-40100	E-12
96600-08018-18	E-10
96700-06125-00	E-1
96700-06032-10	E-7A

98200-30750

F-24

98200-31500

F-24

98200-32000

F-24A

99007-45000

F-26

99620-AAM-201

F-21A

## BLOCK INDEX - GROUP Engine - Karizma ZMR (May, 2014).

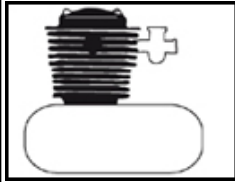

E-1

CYLINDER HEAD COVER

1



E-2

CYLINDER

2



E-3

CAM SHAFT / VALVE

3

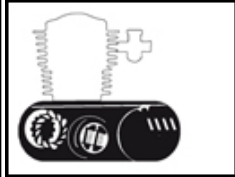

E-4

CAM CHAIN TENSIONER

4



E-5

RIGHT CRANK CASE COVER

5



E-6

CLUTCH

6



E-7

LEFT CRANK CASE COVER

7



E-7A

A.C. GEN. FLYWHEEL

8



E-7B

STARTER MOTOR

9



E-8

CRANK CASE

10



E-8A

OIL PUMP

11

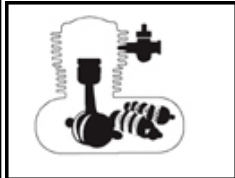

E-9

CRANK SHAFT / PISTON

12



E-10

TRANSMISSION (MAIN SHAFT / COUNTER SHAFT & GEARS)

13



E-12

GEAR SHIFT DRUM

14



E-13











INJECTOR ASSY., FUEL

15







## BLOCK INDEX - GROUP Frame - Karizma ZMR (May, 2014).



	F-1	HEAD LIGHT	16
	F-1A	FRONT COWL	17
	F-1C	COOLER COMP., OIL	18
	F-2	SPEEDOMETER	19
	F-3	FRONT BRAKE MASTER CYL	20
	F-3A	HANDLE LEVER / SWITCH / CABLE	21
	F-4	HANDLE PIPE / TOP BRIDGE / KEY SET	22
	F-5	STEERING STEM	23
	F-6	FRONT FENDER	24
	F-7	FRONT FORK	25









	F-8	CALIPER ASSY. R FR	26
	F-9	FRONT WHEEL	27
	F-10	REAR BRAKE MASTER CYL.	28
	F-10A	CALIPER ASSY. REAR	29
	F-11	REAR WHEEL	30



	F-12	SEAT ASSY. / COWL REAR	31
	F-13	FUEL TANK	32
	F-15	AIR CLEANER	33



	F-16	EXHAUST MUFFLER	34
	F-17	STEP PILLION	35
	F-18	GEAR CHANGE PEDAL	36
	F-18A	MAIN STAND / SIDE STAND	37
	F-19	SWINGARM / CHAIN CASE	38
	F-20	REAR CUSHION	39

## BLOCK INDEX - GROUP Frame - Karizma ZMR (May, 2014).



F-21

REAR FENDER

40

F-21A

REAR INNER FENDER(OPTIONAL)

41

F-22

WINKERS

42

F-23

TAIL LIGHT

43



F-24

WIRE HARNESS

44

F-24A

BATTERY ASSY

45

F-25

FRAME BODY / GRIP REAR

46

F-26

TOOLS

47

F-27

STRIPE / MARKS

48

F-28

SARI GUARD

63

F-29

CAUTION LABEL

64